

NTN[®]

BOWER[®]
An NTN brand manufactured in the USA

CYLINDRICAL AND TAPERED ROLLER BEARINGS



CATALOG A-1500-III

NTN[®]

BOWER[®]
An NTN brand manufactured in the USA

**CYLINDRICAL
AND
TAPERED
ROLLER
BEARINGS**

CATALOG A-1500-III

INTRODUCTION	1
Cylindrical Roller Bearings	1
Tapered Roller Bearings	2
ENGINEERING SECTION	3
Glossary of Symbols	3
Introduction	4
Bearing Life Definition	4
Bearing Load Ratings	5
Bearing Selection	5
<i>Introduction</i>	5
<i>Life Calculation Methods</i>	5
<i>Load Analysis</i>	6
Dead Weight	6
Belts	6
Chain and Sprocket	6
Spur Gears	6
Helical Gears	7
Straight Bevel, Zerol Bevel, Spiral Bevel and Hypoid Gears	7
Imbalance Force	9
Calculation of Bearing Loads	9
<i>A Simplified Method For Figuring Bearing Loads</i>	10
Special Cases	11
Thrust Forces	11
Overhanging Forces	11
Combined Loading Equations	12
<i>Cylindrical Roller Bearings</i>	12
<i>Tapered Roller Bearings</i>	12
<i>Equivalent Radial Load Formulas</i>	13
Single Row Mounting	13
Two Row Mounting—Identical Series	13
Two Row Mounting—Dissimilar Series	13
Load Ratings and Fatigue Life	14
<i>Bearing Life</i>	14
<i>Basic Rated Life & Basic Dynamic Load Rating</i>	14
<i>Adjusted Life Rating Factor</i>	14
a ₁ —Reliability Factor	15
a ₂ —Material/Construction Factor	15
a ₃ —Lubrication Factor	15
a ₄ —Misalignment Factor	16
a ₅ —Load Distribution Factor	16
<i>Weighted Life Equation</i>	16
<i>Basic Static Load Rating</i>	18
<i>Allowable Misalignment</i>	18
Thrust Rating of Cylindrical Roller Bearings	18
Limiting Speeds	19
Effects of Fitting Practice	19
Lubrication	21
<i>Oil vs. Grease</i>	21
Oil	21
Grease	21
<i>Oil</i>	22
<i>Grease</i>	23
Handling and Installation	24

CYLINDRICAL ROLLER BEARINGS – INTRODUCTION	25
Cylindrical Roller Bearings	25
Bearing Design	26
“M” Series Bearings	26
“W” Series Bearings	26
Cages	27
Material	27
Crowned Rollers	27
CYLINDRICAL ROLLER BEARINGS – BEARING SELECTION	29
Numbering System	29
Nomenclature	30
Bearing Types	31
Separable Inner Rings	31
Separable Outer Rings	32
Inner or Outer Ring Omitted	34
Non-separable Bearings	35
Interchange Charts for Basic Series	36
CYLINDRICAL ROLLER BEARINGS – DIMENSIONS AND RATINGS	37
Dimensions	37
Load Ratings	37
“M” Series Lists	38
“W” Series Lists	62
MOJ & MOX Style	72
Custom “R” Series	75
Mast Guide and Chain Guide Bearings	78
ABMA/ANSI Dimensional Tolerances	80
Outer Ring Dowel Holes	81
Outer Ring Groove & Snap Ring Dimensions	82
Internal Diametral Clearance	84
“M” Series Bearings	85
“W” Series Bearings	87
CYLINDRICAL ROLLER BEARINGS – MOUNTING AND FITTING PRACTICE	89
Inner Ring PRESS Fit for Rotating Shaft	91
Inner Ring TAP Fit for Stationary Shaft	93
Outer Ring PUSH Fit For Non-Separable Bearings	95
Outer Ring TAP Fit for Rotating Shaft	97
Outer Ring PRESS Fit for Stationary Shaft	99
Outer Ring HEAVY PRESS Fit – “A” Style	101
Shaft Diameter – Inner Ring Omitted	103
Housing Bore – Outer Ring Omitted	105

TAPERED ROLLER BEARINGS – INTRODUCTION	107
TS Type – Single Row	107
TSF Type – Flanged Cup Single Row	107
TDO Type – Double Cup Two Row	107
TNA Type – Nonadjustable Double Cup Two Row	108
TDI Type – Double Cone Two Row	108
TQO Type – Double Cone Four Row	108
Bearing Design	109
<i>True Rolling Contact</i>	109
<i>Crowned Rollers</i>	109
<i>Material</i>	109
<i>Roller End/Rib Face Geometry</i>	109
<i>Nomenclature</i>	109
 BEARING SELECTION BY BORE SIZE	 110
 TAPERED ROLLER BEARINGS – DIMENSIONS AND RATINGS	 115
Dimensions	115
Load Ratings	115
TS and TSF Type – Single Row	116
TSF Type – Flanged Cup Single Row	173
TDI Type – Double Cone Two Row	175
TQO Type – Double Cone Four Row	175
TDO Type – Double Cup Two Row	180
TNA Type – Nonadjustable Double Cup Two Row	186
TNASWE Type – Nonadjustable Double Cup Two Row	196
 TAPERED ROLLER BEARINGS – TOLERANCES	 198
 TAPERED ROLLER BEARINGS – FITTING PRACTICE TABLES	 200

(This page left intentionally blank.)

Cylindrical Roller Bearings

THE M SERIES designated by the letter M satisfies most commercial applications and is available in a broad range of sizes and types up to 20" (508 mm) outside diameter.

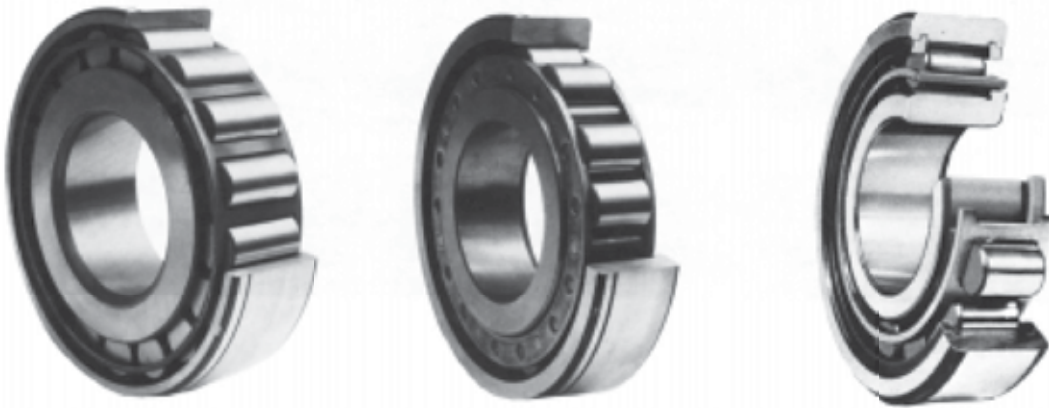

THE MAX-PAK OR W-60000 SERIES is designed for applications with very heavy radial loads and where space for the bearing may be limited. The envelope dimensions are the same as the M series.

THE MOJ SERIES offers economical journal roller assemblies without inner or outer rings for operation in very limited space.



SPECIAL BEARINGS are available for the chain and mast guide, steel mill, rear wheel and pinion applications. Other bearings can be engineered for special requirements.

Tapered Roller Bearings

SINGLE ROW TAPERED ROLLER BEARINGS are available in many different series with straight and flanged cups up to 24" (610 mm) diameter.



TWO ROW TAPERED ROLLER BEARINGS are available in many different series and configurations up to 20" (508 mm) outside diameter.



Two Row Bearing



Two Row Spacer Assembly

Glossary of Symbols

A	Cylindrical bearing inner ring raceway diameter	L'_n	Adjusted bearing life @ n reliability level
a_1	Life adjustment factor for reliability	LH	Left hand
a_2	Life adjustment factor for material	MPD	Mean pitch diameter
a_3	Life adjustment factor for lubrication	N_n	Number of teeth in gear "n"
a_4	Life adjustment factor for misalignment	n	Subscript index
a_5	Life adjustment factor for load zone size	P	Equivalent radial load for tapered roller bearings
B	Bearing inner ring bore	P	Subscript for pinion
C	Cylindrical bearing outer ring raceway diameter	PD	Pitch diameter
Cr	Bearing dynamic load rating (ISO)	p	Radial contact pressure
Cor	Bearing static load rating (ISO)	Q	Torque
CCW	Counterclockwise	R_n	Bearing "n" radial reaction
CF	Centrifugal force	RH	Right hand
CW	Clockwise	r	Radius
D	Bearing outside diameter	S	Rotational speed (rpm)
E	Modulus of elasticity	T_1	Belt tension-tight side
e	Equivalent load factor	T_2	Belt tension-loose side
F	Force	TR_n	Thrust reaction of tapered bearing "n"
F_a	Thrust (Axial) component of F_n or axial force	W	Gear face width
F_n	Normal force	Wt	Weight
F_r	Radial force	Y_1	Axial load factor
F_s	Separating component of F_n	Y_2	Axial load factor
F_t	Tangentail component of F_n	α (alpha)	1/2 included cup angle
f_{pl}	Preload factor	β (beta)	Pitch angle for straight, zerol, and spiral bevel gears
G	Subscript for ring gear	β (beta)	Face angle of hypoid pinion and root angle of hypoid gear
H	Housing O.D.	δ_i (delta)	Change in inner ring raceway diameter
HP	Horsepower	δ_o (delta)	Change in outer ring raceway diameter
IF	Interference fit	ν (nu)	Poisson's ratio
J	Hollow shaft I.D.	Σ (sigma)	Summation
K	Ratio of radial to thrust rating for tapered roller bearings	ϕ (phi)	Normal pressure angle
L_{10}	Bearing life @ 90% reliability level	ϕ_r (phi)	Pressure angle in plane of rotation
L_n	Bearing life @ n reliability level	ψ (psi)	Helix or spiral angle
L'_{10}	Adjusted bearing life @ 90% reliability level		

INTRODUCTION

The selection of the proper bearings for all mechanical systems is essential to the functional and commercial success of that system. The bearings must not only be of the right type, but also the correct size to assure reliability and cost effectiveness. The bearings must be installed properly, supplied with the correct lubricant, and provided with a compatible environment for the system to be successful. This catalog is designed to provide guidelines for the engineer to follow in making proper bearing selection and in establishing an operating environment that will lead to reliable system performance. Because it is impossible to cover all aspects of bearing selection within any text due to the vast number of variables encountered, NTN maintains a staff of Bearing Application Engineers to assist customers in making bearing selections for applications of all kinds. We urge our customers to take advantage of this service. Application engineering assistance may be obtained by calling NTN Sales, or by contacting:

NTN Bearing Corporation of America
Application Engineering Department
1600 E. Bishop Court
Mt. Prospect, IL 60056
847-298-7500 (Fax: 847-294-1208)

BEARING LIFE DEFINITION

All roller bearings have finite lives. Therefore, it is necessary to develop techniques to estimate their lives. Theoretical bearing life is defined as the time (measured in revolutions) to the initial occurrence of rolling contact fatigue on either raceway or any rolling element. Rolling contact fatigue is subsurface initiated damage that occurs after many revolutions of the bearing. When a bearing is rotated under load, the raceways and rolling elements are subjected to cyclic Hertzian stresses as they pass through the load zone. After millions of cycles, microscopic cracks form beneath the bearing surfaces. As the bearing continues to operate, the cracks eventually propagate to the surface causing small particles of steel to break away from the surface. This type of damage is called spalling. See Figure 1.

The laboratory criterion used to define the fatigue

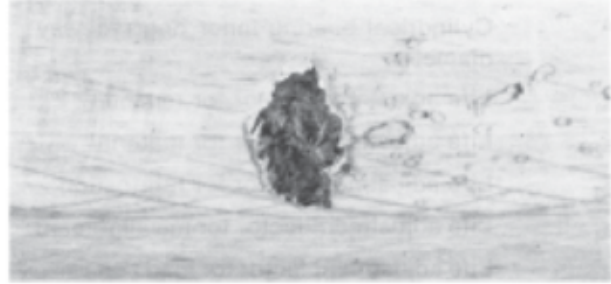

FIGURE 1

life of a bearing is the time period until either raceway or any rolling element develops a spall with an area of 0.01 in² (6 mm²). This definition is necessary for a meaningful comparison of bearing lives under controlled conditions. However, in many applications, a spall of this size may have no immediate or short term adverse effect on total system performance. The size of a spall before a bearing becomes unsuitable for further use is dependent on the nature of the application and how much noise, vibration, or both can be tolerated. The time when a bearing becomes unsuitable for further service is sometimes referred to as its useful life in contrast to its fatigue life. The length of the period between the fatigue life and the useful life is a function of the stress level, the steel alloy and its heat-treatment, and the lubrication. Further information on this subject may be obtained from the NTN Application Engineering Department.

It is impossible to predict the exact fatigue life of an individual bearing. A group of apparently identical bearings subjected to the same conditions of load, speed, lubrication, and temperature will produce a considerable scatter of fatigue lives. Therefore, statistical methods are required to predict the life of the group. The Weibull distribution is generally used to evaluate these types of data. It is common practice to specify the life of the group at the L_{10} level which is the life that 90% of the group will achieve or exceed. Stating this another way, 10% of the group will have experienced fatigue of one or more components at the L_{10} level.

Many other factors besides fatigue may effect bearing performance. These include lubrication, misalignment, contamination, internal operating clearance, etc. Evaluation of these parameters is addressed in the life adjustment factor portion of the Bearing Life Calculations section, page 14.

BEARING LOAD RATINGS

As previously defined, the fatigue life of a rolling bearing is determined by the number of revolutions under load that a bearing experiences prior to the initiation of rolling contact fatigue. Because of the natural scatter of lives in a group of bearings operating under identical conditions, the life of the group is specified at some reliability level, usually 90%. In order to evaluate the life of a bearing in a specific application, a radial load rating has been established for each bearing size. This load rating is based on a 90% survival expectation of a group of bearings operating under a constant radial load for a specific number of revolutions. It is common industry practice to specify the load rating for roller bearings at 1 million revolutions (500 hrs @ 33 1/3 rpm). This rating is designated by the symbol "C_r". These load ratings are tabulated in the appropriate product line sections of this catalog. The use of the load rating to estimate bearing life for a specific application is covered in the Bearing Life Calculations section, page 14.

BEARING SELECTION

Introduction

The prime factors in bearing selection are a total system reliability for its design life and the cost effectiveness. To achieve such reliability, the bearings must be of the proper type and size. The selection process must consider all factors which will affect bearing performance and cost. These factors include:

- Magnitude and direction of loads
- Speed of rotation
- Required life
- Available Space
- Lubrication
- Shaft and housing designs
- Alignment
- Adjustment
- Temperature
- Environment

It is impossible to select any one of these factors as being the most critical. All must be considered in every bearing application. Each application

will dictate their relative importance which will in turn guide the engineer toward proper bearing selection. It is recommended that the NTN Application Engineering Department be consulted on all bearing applications.

Life Calculation Methods

Standard methods for estimating bearing lives have been developed for most applications. Such methods include:

- Maximum horsepower
- Skid torque
- Tractive effort
- Design load
- Work schedule

Whenever possible, the bearing selection for new applications should be based on a comparison of the calculated lives of bearings in similar successful applications using the same method. For example, in truck applications, the wheel bearing life calculations may be based on the design GVW (Gross Vehicle Weight) at 40 mph and the power train on tractive effort methods or specific route schedules. Design bogies are established for each method to assure commercial success of the vehicle. This procedure has proven to be successful in selecting bearings for many different applications. Ongoing programs update calculation methods to make them more realistically correlate with actual field conditions. An engineer must be careful when comparing new and old application calculations that the methods and the bearing ratings are identical. NTN-Bower has established life goals (measured in hours or vehicle roll miles) based on the calculated loads and speeds from the standard evaluation methods. This information is available from the NTN Application Engineering Department.

Load Analysis

In many applications, the load and speed considerations are critical to the bearing selection. Methods of analyzing load sources and the resolution of these loads into bearing reactions are presented below. Frequently, the methods to evaluate the magnitude of the load and the speed are based on a history of performance of similar equipment. Such standard approaches are essential when the bearings are exposed to a full spectrum of loads and speeds and/or a wide variety of work schedules.

The first step in the process is to determine the magnitude and direction of the loads which the bearings are required to support. Loads may originate from a variety of sources including dead weight, belts, chains, sprockets, gears, imbalance, etc. Each load source is discussed below:

Dead weight may be either concentrated or distributed over a given area. For most bearing applications, distributed loads may be resolved into a single concentrated load acting vertically through the center of gravity. For example, the location of the center of gravity in an automobile will determine load distribution between the four wheels. The load at each wheel is distributed over the area of contact between the tire and the road. This load may be considered concentrated at the geometric center of the contact area acting normal to the road surface.

Belts are encountered in a wide variety of industrial applications. They are used for both power transmission and conveyor systems. Power transmission belts may be flat, "V" sectioned, or cogged for timing applications. Conveyor belts are normally flat for moving palletized loads or contoured to a trough shape for bulk materials. Friction between the drive pulley and the belt transmits the motive power in all applications except for cogged timing belts. To assure that sufficient frictional forces exist, the belts must be installed with the proper amount of preload tension. Belt manufacturers provide guidelines to establish the correct value for the preload.

The resultant force created on the drive and idler pulleys in any belt system must include the preload tension, the forces caused by the driving horsepower, and the weight of the material being transported in the case of conveyor systems. When the belt wrap is around 180°, formula (1) approximates the force which must be supported by the pulley bearings.

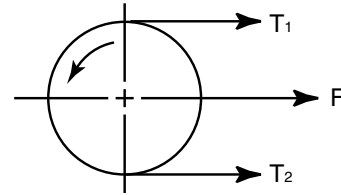

DRIVE PULLEY
FIGURE 2

$$F = T_1 + T_2 = \frac{126050 \times \text{HP} \times f_{pl}}{S \times \text{PD}} \quad (1)$$

- Where: T_1 = Tension on the tight side lb.
 T_2 = Tension on the slack side lb.
 HP = Horsepower
 S = Speed in rpm
 PD = Pulley pitch diameter in.
 f_{pl} = Preload factor
 1.1 to 1.2 cogged belts
 1.5 to 2.0 V-belts
 2.0 to 4.0 flat belts

The relatively wide ranges for the f_{pl} factor are due to the variations in field practices for setting the preload on the belt. Experience with similar installations is necessary for a closer approximation for f_{pl} . Note that in static conditions $T_1 = T_2 =$ preload tension. When the belt wrap varies significantly from 180°, the vector sum of T_1 and T_2 should be used to calculate F.

Chain and sprocket drives do not rely on friction to transmit the motive power to the chain and therefore may have zero or only a small preload. Formula (1) given above for belts is still valid for many chain and sprocket drives using f_{pl} in the range of 1.0 to 1.2. Some sprocket drives, such as used in crawler tractors, may have a heavy preload from hydraulic and/or mechanical systems to keep the track taut. The f_{pl} factor must be significantly increased to account for this preload. For further information, consult with the NTN Application Engineering Department.

Spur gears are the most common type used for positive power transmission between parallel shafts. The faces of the teeth are nearly always of involute form with a pressure angle of 14.5°, 20°, or 25°. The tooth surfaces are parallel to the axis of rotation.

Tangential Component $F_t = \frac{Q \times 2}{PD}$ (2)

Separating Component $F_s = F_t \times \tan \phi$ (3)

Normal Force $F_n = \frac{F_t}{\cos \phi}$ (4)

where Q = Torque (lb•in)

PD = Gear pitch diameter (in)

ϕ = Normal pressure angle (deg)

The direction of the thrust components may be determined from Figure 4. The direction of the tangential and separating components is the same as shown for spur gears in Figure 3.

	Hobbed	Shaped
Tangential Component	$F_t = \frac{Q \times 2}{PD}$ (5)	$F_t = \frac{Q \times 2}{PD}$ (8)

Separating Component	$F_s = \frac{F_t \times \tan \phi}{\cos \psi}$ (6)	$F_s = F_t \times \tan \phi_r$ (9)
----------------------	--	------------------------------------

Axial (Thrust) Component	$F_a = F_t \times \tan \psi$ (7)	$F_a = F_t \times \tan \psi$ (10)
--------------------------	----------------------------------	-----------------------------------

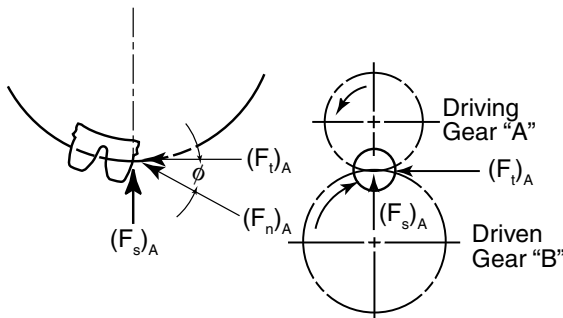

SPUR GEARS
FIGURE 3

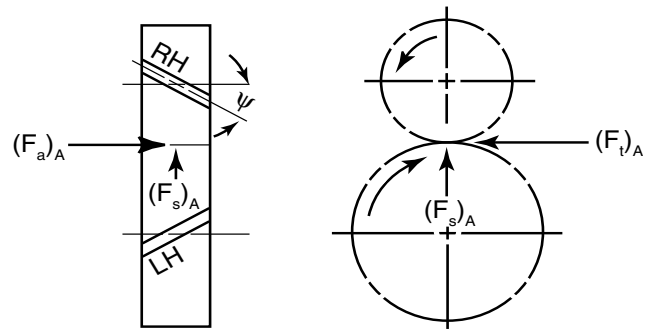

HELICAL GEARS
FIGURE 4

The tangential component is sometimes referred to as the working component since it is directly proportional to the torque transmitted by the shaft. Spur gears may also be operated at a spread center distance in which case the operating pressure angle will increase above the theoretical value. In some bearing load calculations, an engineer may find it convenient to use the normal force.

Helical gears are similar to spur gears except that the teeth form a helix at the pitch diameter of the gear. Helical gears are formed by either hobbing or shaping. The tooth profile and the pressure angle are defined normal to the tooth surface for hobbed gears and in the plane of rotation for shaped gears. The two types will not mesh with each other.

Straight Bevel, Zerol Bevel, Spiral Bevel and Hypoid Gears are used to transmit power between non-parallel shafts; the most common angle between the shafts being 90°. The axes of rotation of the straight, zerol, and spiral bevel gears are coplanar while the axes of the hypoid gears are offset. The pitch diameter is defined at the heel (large end) of the ring gear. Because the load is distributed across the face of the tooth, the mean pitch diameter (defined in equation 11) is used in calculating the gear forces. The mean pitch diameter of the pinion is calculated by equation 12. The tangential components of the gear force are determined for the pinion and the gear by equations 13 and 14. Table I provides the formulas for the separating and thrust components of the ring gear and pinion forces.

$$MPD_G = PD_G - W \sin \beta_G \quad (11)$$

$$(F_t)_P = \frac{Q \times 2}{MPD_P} \quad (13)$$

$$MPD_P = MPD_G \times \frac{N_P}{N_G} \times \frac{\cos \psi_G}{\cos \psi_P} \quad (12)$$

$$(F_t)_G = (F_t)_P \times \frac{\cos \psi_G}{\cos \psi_P} \quad (14)$$

TABLE I

Driving Member Hand & Rotation	Axial Component (Thrust)	Separating Component
RH/CW OR LH/CCW	Driving Member $F_a = \frac{F_t}{\cos \psi} (\tan \phi \sin \beta - \sin \psi \cos \beta)$	Driving Member $F_s = \frac{F_t}{\cos \psi} (\tan \phi \cos \beta + \sin \psi \sin \beta)$
	Driven Member $F_a = \frac{F_t}{\cos \psi} (\tan \phi \sin \beta + \sin \psi \cos \beta)$	Driven Member $F_s = \frac{F_t}{\cos \psi} (\tan \phi \cos \beta - \sin \psi \sin \beta)$
RH/CCW OR LH/CW	Driving Member $F_a = \frac{F_t}{\cos \psi} (\tan \phi \sin \beta + \sin \psi \cos \beta)$	Driving Member $F_s = \frac{F_t}{\cos \psi} (\tan \phi \cos \beta - \sin \psi \sin \beta)$
	Driven Member $F_a = \frac{F_t}{\cos \psi} (\tan \phi \sin \beta - \sin \psi \cos \beta)$	Driven Member $F_s = \frac{F_t}{\cos \psi} (\tan \phi \cos \beta + \sin \psi \sin \beta)$

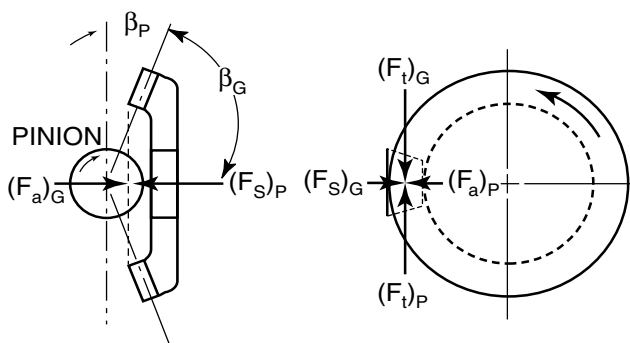

STRAIGHT, ZEROL, AND SPIRAL BEVEL GEARS
FIGURE 5

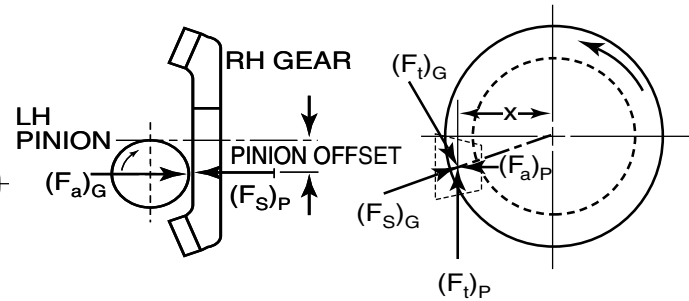

HYPOID GEARS
FIGURE 6

- The appropriate values of ϕ , ψ , and β for the driving and driven member must be used, respectively.
- A positive (+) value indicates the gears are separating.
- A negative (-) value indicates the gears are being drawn together.
- The load point on a hypoid pinion is determined from the offset and the MPD_G as shown in Figure 6.
- For straight and zerol bevel gears, $\psi = 0$, therefore simplifying the equations in Table I.
- For hypoid gears, β equals the face angle of the pinion and the root angle of the gear.

$$x = \left[\left(\frac{MPD_G}{2} \right)^2 - \text{offset}^2 \right]^{1/2} \quad (15)$$

An Imbalance Force is generated when a mass rotates on an axis offset from its center of gravity. This imbalance, called a centrifugal force, will put an additional load on the support bearings. This load direction will remain stationary in regard to the rotating ring. The magnitude of the centrifugal force may be determined from equation 16.

$$C.F. = \frac{Wt \times r \times S^2}{3.52 \times 10^4} \text{ lb.} \quad (16)$$

The evaluation of a combination of rotating loads and stationary loads is a complex calculation and should be referred to the NTN Application Engineering Department.

THE CALCULATION OF BEARING LOADS

Before the actual bearing loads can be calculated, the bearing spread must be defined. For a shaft supported on two bearings, the bearing spread is defined as the distance between the two points which are considered to be the center of support for the load on the bearing. For cylindrical roller bearings, the point is defined as the intersection of the axis of rotation of the bearings and a plane normal to the axis through the midpoint of the roller length. See Figure 7.

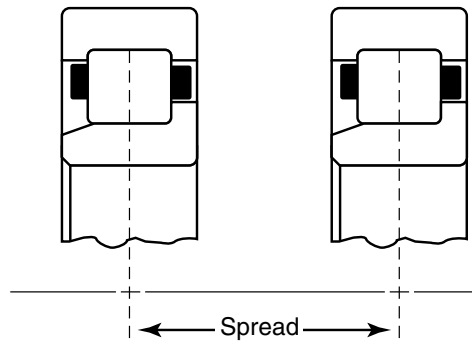

FIGURE 7

DIRECT MOUNTING

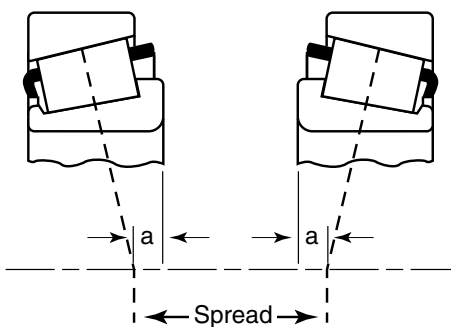

FIGURE 8

INDIRECT MOUNTING

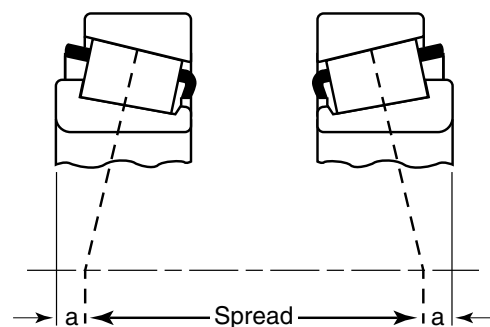

FIGURE 9

For tapered roller bearings, the load on the bearing is considered to be normal to the shaft at a point which is the intersection of the axis of rotation and a line which is projected normal to the cup surface from the midpoint of the roller contact. This point is called the effective load center for a single row tapered roller bearing and is located at dimension "a" from the back face of the cone. This dimension "a" is tabulated for each cone in the dimensional data of the series listing of tapered roller bearings. For double row tapered roller bearings, the geometric center of the pair is used as the load center unless the external thrust load is sufficient to unseat one row in which case the effective center of the loaded row is used.

Single row tapered roller bearings may be mounted in either a direct mounting (Figure 8) or an indirect mounting (Figure 9). The direct mounting is frequently found in countershafts of transmissions in order to provide and end play adjustment through the stationary cups. The indirect mounting is common in wheel assemblies in order to provide greater stability to the assembly and, also, to allow for end play adjustment through the stationary cones. Certain thermal considerations may also influence the design and/or the end play recommendation. For further information, please contact the NTN Application Engineering Department.

A Simplified Method For Figuring Bearing Loads

The simplified method for solving bearing loads described below is merely a condensed or consolidated version of standard methods of basic mechanics. It makes full use of the basic laws of equilibrium, namely, for any system of forces:

Where: ΣF = Summation of forces = 0
 ΣM = Summation of moments about an arbitrary point = 0

Combining these laws with the Pythagorean theorem, the required bearing loads are easily determined. It must be remembered that the applied loads and moments in conjunction with the bearing reactions create equilibrium for the system. The following rules provide an orderly procedure which will minimize the chance of error.

1. Break all forces into components that may be projected onto one of two convenient planes passing through the shaft centerline and at right angles to each other. These convenient planes will normally be horizontal and vertical and will, hereafter, be referred to as such.
2. The sign of the moment of a force about a point in its plane will be regarded as positive if the sense of rotation is counterclockwise and negative if the sense of rotation is clockwise.



3. Always use the right hand bearing as the moment-center.
4. Solve for the left bearing load components by taking moments of all the forces about the right hand bearing and **DIVIDING THEIR ALGEBRAIC SUM BY THE BEARING SPREAD**. Combine the equations for the horizontal and vertical components by the Pythagorean theorem and solve for the bearing load.

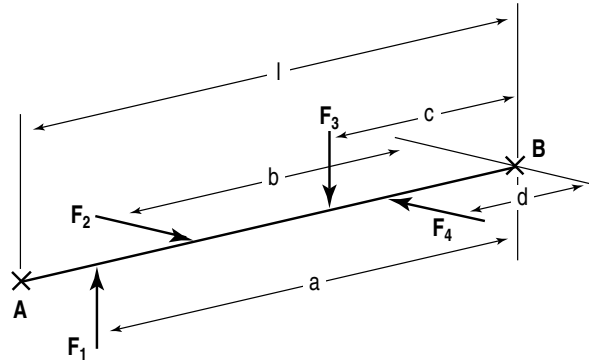

Example 1:

Vertical Component	Horizontal Component
$\pm V_A$	$\pm H_A$
$R_A = \left[\left(\frac{-F_1 \times a + F_3 \times c}{l} \right)^2 + \left(\frac{F_2 \times b - F_4 \times d}{l} \right)^2 \right]^{1/2} \quad (17)$	

In any pair of bearings, the second bearing load (R_B) may be found by the summation of forces. This summation will include the components of R_A , remembering that the reaction of R_A must be used as the load on the shaft, hence, the load components of R_A must be multiplied by minus one.

$$R_B = [(-F_1 + F_3 \mp V_A)^2 + (F_2 - F_4 \mp H_A)^2]^{1/2} \quad (18)$$

By locating equation 18 near equation 17, the equation for R_B may be set up by taking the load figures directly from the equation for R_A without further reference to the diagram.

Vertical Component	Horizontal Component
$\pm V_A$	$\pm H_A$
$R_A = \left[\left(\frac{-F_1 \times a + F_3 \times c}{l} \right)^2 + \left(\frac{F_2 \times b - F_4 \times d}{l} \right)^2 \right]^{1/2} \quad (17)$	

$$R_B = [(-F_1 + F_3 \mp V_A)^2 + (F_2 - F_4 \mp H_A)^2]^{1/2} \quad (18)$$

Note that the sign of the individual forces is the same for R_B as it was in R_A while the signs for the components V_A and H_A have been reversed as previously explained.

SPECIAL CASES

- Thrust Forces.** Thrust forces are reduced to components in the two specified planes and moments are taken about the right hand bearing to solve R_A . When solving for the second bearing load, it must be remembered that the thrust components are parallel to the axis of the shaft and, therefore, do not enter into the summation of the horizontal or vertical forces.

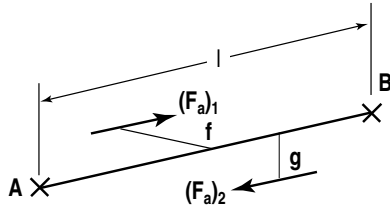

Example 2:

$$R_A = \left[\left(\frac{-V_A}{l} \right)^2 + \left(\frac{-H_A}{l} \right)^2 \right]^{1/2} \quad (19)$$

$$R_B = [(+V_A)^2 + (+H_A)^2]^{1/2} \quad (20)$$

Combine examples 1 and 2.

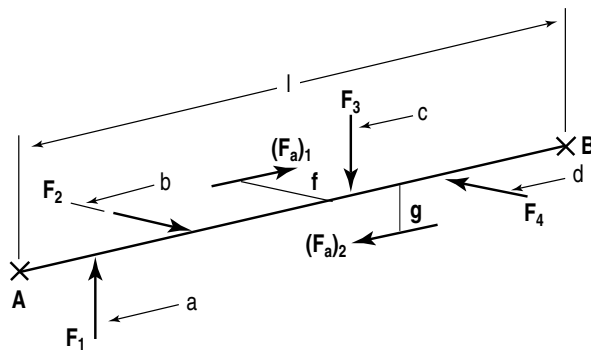

Example 3:

$$R_A = \left[\left(\frac{\pm V_A}{l} \right)^2 + \left(\frac{\pm H_A}{l} \right)^2 \right]^{1/2} \quad (23)$$

$$R_B = [(F_5 + F_7 \mp V_A)^2 + (-F_6 \mp H_A)^2]^{1/2} \quad (24)$$

Note: By definition, F_6 and F_7 are overhanging forces and therefore require a change in sign in solving for R_B by summation of forces. Also, by definition, F_5 is **not** considered an overhanging force.

$$R_A = \left[\left(\frac{\pm V_A}{l} \right)^2 + \left(\frac{\pm H_A}{l} \right)^2 \right]^{1/2} \quad (21)$$

$$R_B = [(-F_1 + F_3 \mp V_A)^2 + (F_2 - F_4 \mp H_A)^2]^{1/2} \quad (22)$$

- Overhanging Forces.** Definition: An overhanging force is any force so located (1) as to not be between the two support points, and (2) as to not have one of the supports between it and the moment-center. Thus, when the right hand support is used as the moment-center, all forces to the right of the right hand support (moment-center) are overhanging forces.

Rule: When carrying the value of the overhanging force down to solve for R_B , the sign must be reversed. This is obvious from the fact that a shaft loading consisting of only an overhanging force, the two support reactions are of the opposite sense. It may be necessary to refer to a diagram here to avoid missing an overhanging force with reference to R_B .

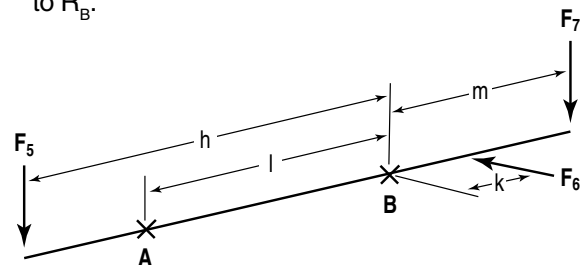

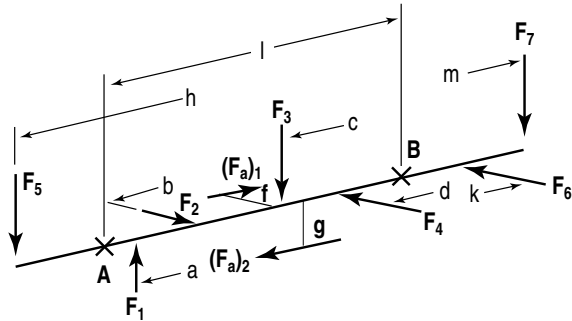

Combine examples 1, 2, and 3.

$$R_A = \left[\left(\frac{\pm V_A}{l} \left(-F_1 \times a + F_3 \times c + F_5 \times h - (F_a)_2 \times g - F_7 \times m \right) \right)^2 + \left(\frac{\pm H_A}{l} \left(F_2 \times b - F_4 \times d - (F_a)_1 \times f + F_6 \times k \right) \right)^2 \right]^{1/2} \quad (25)$$

$$R_B = [(-F_1 + F_3 + F_5 + F_7 \mp V_A)^2 + (F_2 - F_4 - F_6 \mp H_A)^2]^{1/2} \quad (26)$$

Suggestions:

1. If the overhanging forces are always located at the end of each component in the equation, the possibility of overlooking them and the accompanying sign change will be reduced.
2. It will be much easier to learn one set of rules and always use the right hand support as the moment-center; however, the left hand support may be used if it is necessary. When using the left hand support as the moment-center, the signs for clockwise and counterclockwise rotation must be reversed. All other rules remain the same. Be sure to follow the strict definition of an overhanging force.

COMBINED LOADING EQUATIONS

Bearings are frequently required to support a combination of radial and thrust loads. In order to calculate the bearing life under such conditions, it is necessary to calculate an Equivalent Radial Load. The theoretical bearing life under combined radial and thrust loading conditions will be the same as that which would be expected under a pure radial load equal to the Equivalent Radial Load.

Cylindrical Roller Bearings

Cylindrical roller bearings with opposed solid ribs on the inner and outer rings will support light to moderate thrust loads. The maximum thrust load that a cylindrical roller bearing will support is defined later in this section. Field experience and laboratory tests have proven that as long as the applied thrust load is less than the applied radial load and less than the limiting thrust rating, the fatigue life of the bearing will not be adversely affected. Therefore, the fatigue life of a cylindrical roller bearing under such combined loading conditions will be equivalent to the life under the applied radial load. The Equivalent Radial Load concept is not applicable to cylindrical roller bearings.

Tapered Roller Bearings

Tapered roller bearings, due to their basic design, generate a thrust reaction when subjected to a radial load. The magnitude of this thrust reaction is a function of the load, the included cup angle, and the size of the load zone within the bearing. For convenience in load and life calculations, a Y_2 factor has been assigned to each tapered bearing series. This factor is defined for single row bearings as:

$$Y_2 = 0.4 \cot \alpha \quad (27)$$

Where $\alpha = 1/2$ included cup angle

When the load on bearing (A) is pure radial (R_A) and the load zone within the bearing is 180° or less, the approximate thrust reaction (TR_A) is:

$$TR_A = \frac{0.50 R_A}{(Y_2)_A} \quad (28)$$

When the load zone on bearing (B) approaches 360° due to a combined radial load (R_B) and an external thrust load, its approximate thrust reaction is:

$$TR_B = \frac{0.60 R_B}{(Y_2)_B} \quad (29)$$

These thrust reactions are a critical part of the Equivalent Radial Load equations for tapered roller bearings.

The general ABMA equation for the equivalent radial load is:

$$P = X F_r + Y F_a \quad (30)$$

Where: P = Equivalent radial load
 F_r = Applied radial load
 F_a = Applied thrust load
 X = Radial load factor
 Y = Thrust load factor

The values of X and Y are determined using Table 2:

TABLE 2

Bearing Config.	$\frac{F_a}{F_r} \leq e$		$\frac{F_a}{F_r} > e$	
	X	Y	X	Y
Single	1.00	0.00	0.40	Y_2
Double	1.00	Y_1	0.67	Y_2

Values for e, Y_1 , and Y_2 are listed in the tapered roller bearing dimension tables.

In the calculation of the equivalent radial load for a tapered roller bearing, the algebraic sum of all external thrust loads and the thrust reactions of the bearings must be considered. All factors are automatically included in the Equivalent Radial Load formulas shown in Table 3 through 5. Note, when the calculated Equivalent Radial Load is less than the applied radial load, the radial load alone is used to estimate the bearing life.

Equivalent Radial Load Formulas

Single Row Mounting

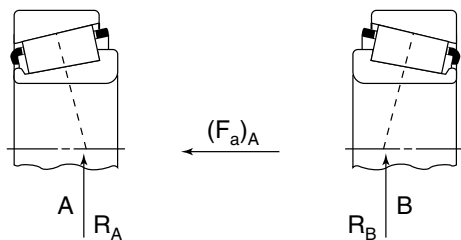

TABLE 3

Thrust Condition	Equivalent Radial Load
$\frac{0.5R_A}{Y_A} < \frac{0.5R_B}{Y_B} + (F_a)_A$	$P_A = 0.4R_A + Y_A \left(\frac{0.5R_B}{Y_B} + (F_a)_A \right)$ $P_B = R_B$
$\frac{0.5R_A}{Y_A} > \frac{0.5R_B}{Y_B} + (F_a)_A$	$P_A = R_A$ $P_B = 0.4R_B + Y_B \left(\frac{0.5R_A}{Y_A} - (F_a)_A \right)$

Two Row Mounting - Identical Series

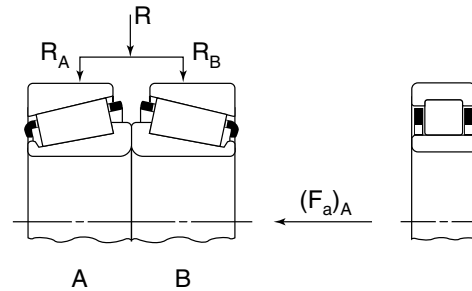

TABLE 4

Thrust Condition	Equivalent Radial Load
$(F_a)_A < \frac{0.6R}{Y_A}$	$P_A = \frac{R}{2} + 0.83 Y_A (F_a)_A$ $P_B = \frac{R}{2} - 0.83 Y_A (F_a)_A$
$(F_a)_A > \frac{0.6R}{Y_A}$	$P_A = 0.4R + Y_A (F_a)_A$ $P_B = 0$

Two Row Mounting - Dissimilar Series

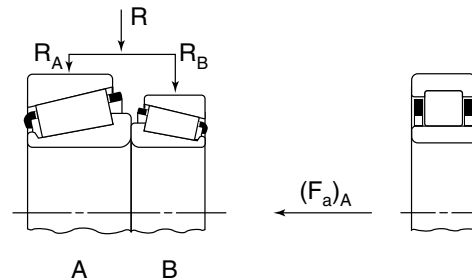

TABLE 5

Thrust Condition	Equivalent Radial Load
$(F_a)_A < \frac{0.6R}{Y_A}$	$P_A = \frac{Y_A}{Y_A + Y_B} (R + 1.67 Y_B (F_a)_A)$ $P_B = \frac{Y_B}{Y_A + Y_B} (R - 1.67 Y_A (F_a)_A)$
$(F_a)_A > \frac{0.6R}{Y_A}$	$P_A = 0.4R + Y_A (F_a)_A$ $P_B = 0$

Where:

- R = Total radial load—lbs.
- R_A = Radial load, brg. A—lbs.
- R_B = Radial load, brg. B—lbs.
- $(F_a)_A$ = External thrust on brg. A*—lbs.
- Y_A = Axial load factor brg. A
- Y_B = Axial load factor brg. B
- P_A = Equivalent radial load, brg. A—lbs.
- P_B = Equivalent radial load, brg. B—lbs.

* When there are no external thrust loads $F_a = 0$ in equations above.

LOAD RATINGS AND FATIGUE LIFE

Bearing Life

Even in bearings operating under normal conditions, the surfaces of the raceway and rolling elements are constantly subjected to stresses which cause flaking of these surfaces to occur. This flaking is due to material fatigue, and will eventually cause the bearings to fail. The effective life of a bearing is usually defined in terms of the total number of revolutions a bearing can undergo before flaking of either the raceway surface or the rolling element surfaces occurs.

Other causes of bearing failure are attributed to problems such as seizing, abrasions, cracking, chipping, rust, etc. However, the “causes” of bearing failure are usually themselves caused by improper installation, insufficient or improper lubrication, faulty sealing or inaccurate bearing selection. Since these “causes” of bearing failure can be avoided by taking the proper precautions, and are not simply caused by material fatigue, they are considered separately from the flaking aspect.

Basic Rated Life & Basic Dynamic Load Rating

Basic rated bearing life is based on a 90% statistical model which is expressed as the total number of revolutions 90% of the bearings in an identical group, subjected to identical operating conditions, will attain or surpass before flaking due to material fatigue occurs. For bearings operating at fixed constant speeds, the basic rated life (90% reliability) is expressed in the total number of hours of operation.

The basic dynamic load rating is an expression of the load capacity of a bearing based on a constant load which the bearing can sustain for one million revolutions (the basic life rating). The basic dynamic load ratings

given in the bearing tables of this catalog are for bearings constructed of NTN standard bearing materials, using standard manufacturing techniques. Please consult NTN for basic load ratings of bearings constructed of special materials or using special manufacturing techniques.

The relationship between the basic rated life, the basic dynamic load rating and the bearing load is given in the formula

$$L_{10} = \left(\frac{C_r}{P_r} \right)^{10/3} \quad (31)$$

Where:

- L_{10} : Basic rated life in 10^6 revolutions
- C_r : Basic dynamic radial rated load
- P_r : Equivalent radial load

The basic rated life can also be expressed in terms of hours of operation, and is calculated by modifying the equation above as follows:

$$L_{10h} = \frac{10^6}{60 \times n} \left(\frac{C_r}{P_r} \right)^{10/3} \quad (32)$$

Where:

- L_{10h} : Basic rated life in hours
- n : Rotational speed; (rpm)

Adjusted Life Rating Factor

The basic bearing life rating (90% reliability factor) can be calculated through the formulas mentioned above. However, in some applications a bearing life factor of over 90% reliability may be required. To meet this requirement, bearing life can be lengthened by the use of special bearing materials or special construction techniques. In addition, the elastohydrodynamic

lubrication theory shows that bearing operating conditions (lubrication, temperature, speed, etc.) exert an effect on bearing life as well. All these factors are taken into consideration when calculating bearing life, and using the life adjustment factor as prescribed in ISO 281, the adjusted bearing life can be arrived at:

$$L_{na} = a_1 \times a_2 \times a_3 \times a_4 \times a_5 \frac{10^6}{60 \times n} \left(\frac{C_r}{P_r} \right)^{10/3} \quad (33)$$

Where:

- L_{na} : Adjusted life rating in hours; adjusted for reliability, material and operating conditions
- a_1 : Reliability factor
- a_2 : Material/construction factor
- a_3 : Lubrication factor
- a_4 : Misalignment factor
- a_5 : Load distribution factor

a_1 —Reliability Factor

As previously defined, normal industry practice and the radial load ratings in this catalog are based on the 90% reliability level. In some applications, a more stringent reliability level may be required. As defined by ABMA, the reliability factor is:

$$a_1 = 4.48 \times \left[\ln \frac{100}{R} \right]^{2/3} \quad (34)$$

For convenience, specific values are shown in Table 6.

TABLE 6

Reliability Level %	L_n	Life Adjustment Factor a_1
90	L_{10}	1.00
95	L_5	0.62
96	L_4	0.53
97	L_3	0.44
98	L_2	0.33
99	L_1	0.21

a_2 —Material/Construction Factor

Most NTN-Bower bearings are manufactured from carburizing grades of alloy steels processed to meet exacting bearing quality standards. A few special products utilize alternate materials specifically selected for their intended applications.

All load ratings published in this catalog reflect the use of case carburized bearing quality alloy steel. Therefore, the material factor (a_2) is equal to 1.4.

In some applications, it may not be possible to find a standard bearing with adequate fatigue life within the boundary restraints. To avoid the necessity of a redesign of the entire system, bearings manufactured from premium materials have longer fatigue life due to fewer and more widely separated non-metallic inclusions in the steel matrix, which reduces the number and severity of possible fatigue initiation sites. NTN has established material life adjustment factors for these premium steels as shown on Table 7.

NTN-Bower also offers advanced heat treatment options that improve the fatigue life of the bearing. Austenite strengthening ('AS') treatment can increase the fatigue life of a bearing by 50%.

In order to offer optimum bearing performance for special applications, NTN-Bower has developed the Extended Life (XL100) tapered roller bearing line. XL100 construction uses optimal material and heat treatment to increase fatigue life as well as other internal modifications to enhance performance.

The values for the material/construction factor a_2 can be found in Table 7.

TABLE 7

Material/ Construction	Life Adjustment Factor a_2
Standard (case carburized steel)	1.4
XL100 Construction	1.9
'AS' Treatment (case carburized steel)	2.1
'AS' + XL100 Construction	2.8

a_3 —Lubrication Factor

The lubricant selected for the application, the operating temperature, and the bearing load and speed combine to affect bearing life. When any of these deviate substantially from the base conditions, the expected bearing life can be adjusted by the lubrication life factor a_3 . In general, higher viscosity lubricants, higher speeds, and lower temperatures yield an adjustment factor greater than 1.0 ($a_3 > 1.0$). Figures 10 through 13 are used to approximate the lubrication factor - a_3 . This procedure is intended only to provide a ballpark figure for a_3 .

NTN has developed the long life HL (High Lubrication) bearing, to help increase the film thickness between the contact elements and thus alleviate the problem of surface flaking under poor lubrication conditions.

For a more exact determination of a_3 and for more information on NTN's HL bearing, contact the NTN Application Engineering Department.

a_4 —Misalignment Factor

Although bearings should be perfectly aligned, some degree of misalignment is virtually always present in an application. A small degree of misalignment is allowed for in the bearing ratios. However, the factor, a_4 , should be considered when misalignment exceeds a value of 0.001 radian. Misalignment is a measurement of the angle between the axis of rotation of the outer ring. Figure 14 is used to estimate the misalignment factor— a_4 for cylindrical and tapered roller bearings. For a more exact evaluation, contact the NTN Application Engineering Department.

a_5 —Load Distribution Factor

The distribution of load within a bearing is a function of mounted clearance, support stiffness and the magnitude of the load. For a given application there exists an optimum mounted internal clearance to maximize a bearing's fatigue life. The proper selection of the fitting practice for cylindrical roller bearings with preset radial clearance is critical to bearing performance. For adjustable tapered roller bearings, the opportunity exists to optimize bearing performance through adjustment methods.

The technique used to estimate the influence of internal clearance on fatigue life involves the computer analysis of many variables. The bearing user should consult the NTN Application Engineering Department for evaluation of the load distribution factor.

Weighted Life Equation

Bearing selection is sometimes based on life expectancy at maximum load and speed requirements. However, in some applications, the load and/or speed may vary at different time intervals. Therefore, a more economical bearing selection can be considered if these variations are evaluated to determine a weighted life for the bearing.

To determine a weighted bearing L_{10} life in hours where the life at various conditions has been determined and a work schedule is known, use equation (35).

$$L_{WT} = \frac{1}{\frac{T_1}{L_{10_1}} + \frac{T_2}{L_{10_2}} + \dots + \frac{T_n}{L_{10_n}}} \quad (35)$$

Where:

L_{10} = Life in Hours

T_1, T_2, \dots, T_n = Time in % of Total Time occurring during a loading cycle

L_{WT} = Weighted L_{10} Life

Example:

Given: Selected bearing has $Cr = 27,800$ lbs for rear countershaft position on five speed truck transmission. Operating schedule tabulated above.

Truck Operating Schedule

Gear	Load(P) lbs	Speed (S) rpm	Time(T) %	Life(L_{10}) hrs
1st	16190	100	3	1010
2nd	8550	400	5	2122
3rd	5850	900	30	3341
4th	3840	1200	42	10195
5th	2880	1500	20	21278

Problem: Determine weighted L_{10} life of selected bearing

$$L_{WT} = \frac{1}{\frac{.03}{1010} + \frac{.05}{2122} + \frac{.30}{3341} + \frac{.42}{10195} + \frac{.20}{21278}} = 5164 \text{ hrs.}$$

a₃ – Lubrication Factor Approximation

Figure 10

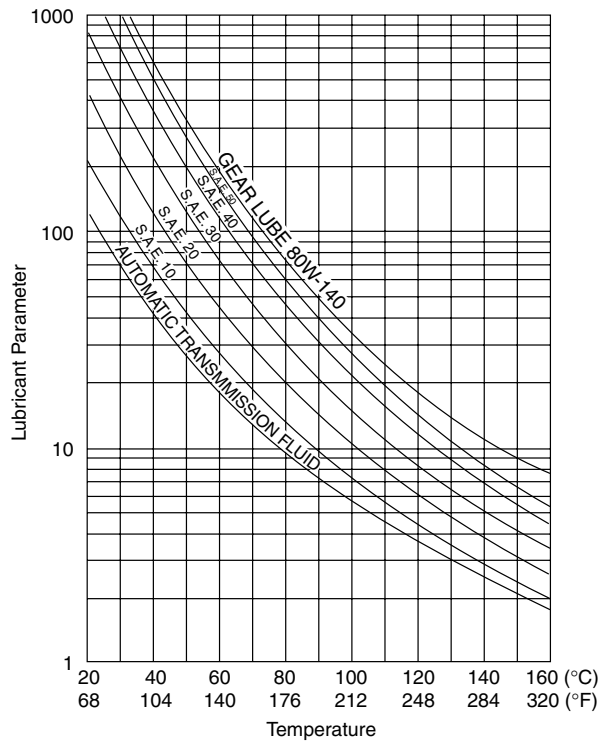

Figure 11

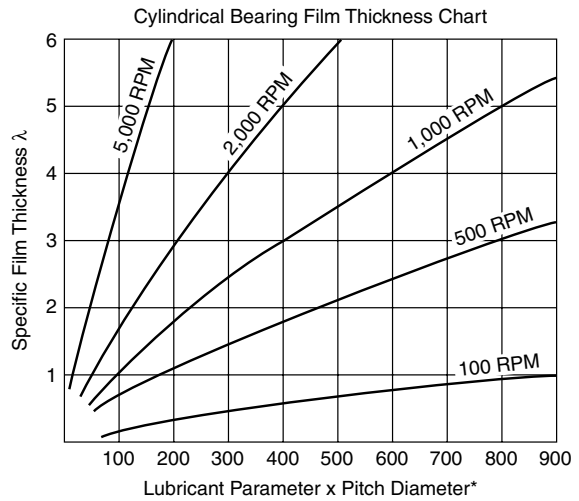

Figure 12

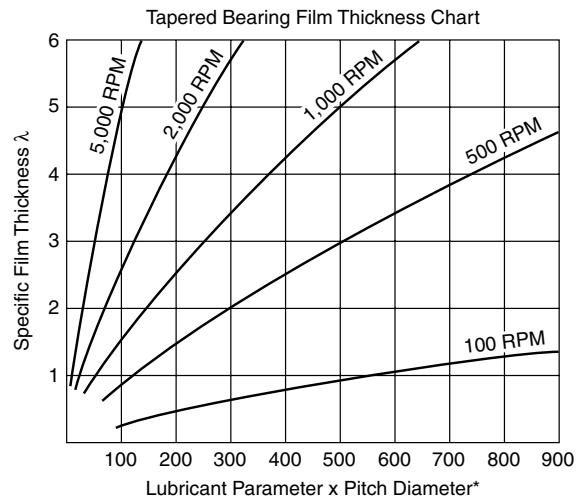
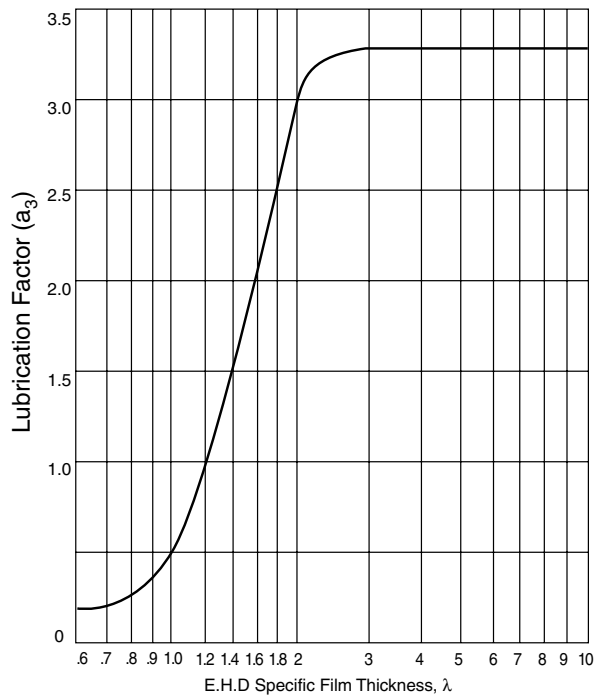

Figure 13



INSTRUCTIONS

1. Determine Lubricant Parameter according to temperature and type of Lubricant from Figure 10.
2. Multiply Lubricant Parameter by Bearing Pitch Diameter*.
3. Determine Specific Film Thickness “λ” from Figure 11 or 12.
4. Determine Lubrication Factor “a₃” from Figure 13.

*Pitch Diameter (in.) = $\frac{\text{Bore Diameter} + \text{Outside Diameter}}{2}$

Figure 14

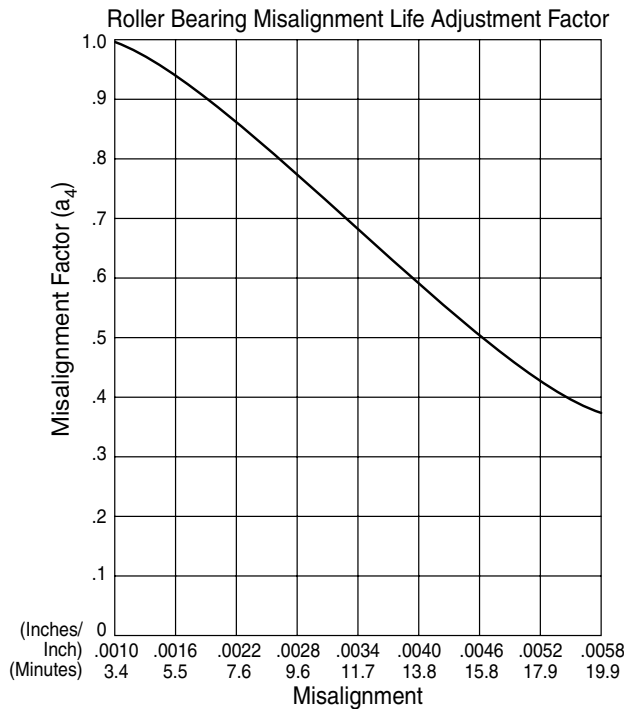

Basic Static Load Rating

When stationary roller bearings are subjected to static loads of moderate magnitude, they suffer from partial permanent deformation of the contact surfaces at the contact point between the rolling elements and the raceway. The amount of deformity increases as the load increases, and if this increase in load exceeds certain limits, the subsequent smooth operation of the bearings is impaired.

It has been found that a permanent deformity of 0.0001 times the diameter of the rolling element, occurring at the most heavily stressed contact point between the raceway and rolling elements, can be tolerated with negligible impairment in running efficiency.

The basic static load rating refers to a fixed static load limit at which a specified amount of permanent deformation occurs. The maximum applied load values for contact stress occurring at the rolling element and raceway contact points for roller bearings is 4,000 MPa.

Allowable Misalignment

Optimized design for roller and raceway contact, not only prevents the occurrence of roller edge loading at the contact surface, but also tolerates some misalignment between the inner and outer rings for mounting error. The allowable misalignment for cylindrical roller bearings is approximately 0.001 radian (0°, 3.5') for width series 1 bearings and 0.0005 radian (0°, 1.5') for width series 5 and 7 bearings.

THRUST RATING OF CYLINDRICAL ROLLER BEARINGS

Cylindrical roller bearings with opposed integral ribs on the inner and outer rings can support light to moderate thrust loads. The mechanism for supporting the thrust load in a cylindrical roller bearing is different from that in any other type of rolling bearing. In a ball bearing, the thrust load, as well as the radial load, is carried through the rolling contact between the balls and the raceways. In a tapered roller bearing, the major portion of the thrust load is carried on the rolling contact between the O.D. of the rollers and the raceways and the balance of sliding contact of the spherical head against the large cone flange. The cylindrical roller bearing can only support thrust loads on the ends of the rollers in a sliding contact with the raceway ribs, thus limiting thrust load carrying capabilities.

Several important factors must be considered when using cylindrical roller bearings in thrust applications. The thrust reactions at the diametrically opposed raceway ribs create a radial overturning moment on the roller and the sliding action creates a circumferential skewing moment. To overcome the radial moment and stabilize the roller, the applied radial load must be greater than the thrust load. The longer rollers in wide series cylindrical roller bearings are more adversely affected by the skewing moment and, therefore, are more restricted in thrust capabilities. The shaft alignment must be within 0.0001 radian of the true position to obtain equal load sharing between the rollers. Because of the sliding action, the lubricant must provide an adequate film between the roller ends and the raceway ribs; high viscosity oil is preferred.

LIMITING SPEEDS

Because of the many factors involved in determining the speed capabilities of a rolling bearing, it is impossible to develop a simple formula to establish an exact value for the limiting speed. Besides the precision of the bearing itself, the magnitude and direction of the load, the type of cage, the type of lubricant and lubrication system, the rate of heat dissipation, the alignment, the mounting practice, and the balance of the rotating components all play a significant role.

Since each application must be evaluated on its own merits, it is recommended the NTN Application Engineering Department be consulted when the speed approaches the limiting value.

EFFECTS OF FITTING PRACTICE

Cylindrical roller bearings are manufactured with a preset amount of radial clearance. They are available in two styles, the standard series and the "A" series. The standard series is designed to be installed with a press fit on one ring and a tap fit on the other as defined in the cylindrical roller bearing fitting practice section of this catalog, pages 89-105. The "A" series is designed for a press fit on the inner ring and a heavy press fit on the outer ring which are required for heavy duty applications.

The press fit of either the inner ring or the outer ring reduces the radial clearance within the bearing. This reduction in clearance has been compensated for at the time of bearing manufacture. Therefore, it is essential that the recommended fitting practices be adhered to in order to assure that the bearing will operate with the proper installed clearance.

The inner ring will expand according to equation (36) for the general case

$$\delta_i = \frac{p_i A}{E_1} \left[\frac{2 \times B^2}{A^2 - B^2} \right] \quad (36)$$

Where: δ_i = Expansion of inner ring raceway diameter (in)
 p_i = Radial contact pressure between inner ring and shaft (psi)
 A = Inner ring raceway diameter (in)
 B = Inner ring bore (in)
 E_1 = Inner ring modulus of elasticity
 = 30×10^6 psi

For a solid steel shaft equation (36) reduces to:

$$\delta_i = \frac{B}{A} (IF)_i \quad (37)$$

The outer ring will contract according to equation (38) for the general case.

$$\delta_o = \frac{-p_o C}{E_1} \left[\frac{2 \times D^2}{D^2 - C^2} \right] \quad (38)$$

Where: δ_o = Contraction of outer ring raceway (in)
 p_o = Radial contact pressure between outer ring and housing (psi)
 C = Outer ring raceway diameter (in)
 D = Outer ring O.D. (in)
 E_1 = Outer ring modulus of elasticity
 = 30×10^6 psi

For massive steel housing equation (38) reduces to

$$\delta_o = \frac{-C}{D} (IF)_o \quad (39)$$

For the general case, p_i and p_o may be solved for from the following equations, respectively:

$$(IF)_i = \frac{p_i B}{E_1} \left[\frac{A^2 + B^2}{A^2 - B^2} + v_1 \right] + \frac{p_i B}{E_2} \left[\frac{B^2 + J^2}{B^2 - J^2} - v_2 \right] \quad (40)$$

$$(IF)_o = \frac{p_o D}{E_1} \left[\frac{D^2 + C^2}{D^2 - C^2} - v_1 \right] + \frac{p_o D}{E_3} \left[\frac{H^2 + D^2}{H^2 - D^2} + v_3 \right] \quad (41)$$

- Where: $(IF)_i$ = Interference fit of inner ring on shaft (in)
 $(IF)_o$ = Interference fit of outer ring in housing (in)
 v_1 = Poisson's ratio for bearing rings = 0.27
 E_2 = Modulus of elasticity for shaft (psi)
 v_2 = Poisson's ratio for shaft
 E_3 = Modulus of elasticity for housing (psi)
 v_3 = Poisson's ratio for housing
 A = Inner ring raceway
 B = Inner ring bore
 C = Outer ring raceway diameter
 D = Outer ring O.D.
 J = Hollow shaft bore
 H = Housing O.D.

Tapered roller bearings have a more complex reaction to interference fits. Not only do the bearing raceways change in a radial direction, but, due to the tapered relationship of the raceways, there is also an expansion of bearing width which may effect the bearing setting. Please consult NTN Application Engineering Department for further information.

LUBRICATION

The following information on lubrication is intended only as a general guide. Due to the complexity of the subject, contact NTN Application Engineering Department for recommendations on specific applications.

To obtain the full, calculated life of a bearing in an application, it is essential to select an adequate lubricant viscosity and method of lubrication.

The necessary data and formula to adjust bearing life for oil film thickness, based on the Elastohydrodynamic Theory (EHD), is provided in the “Bearing Selection” section under “Life Adjustment Factors” on page 15. Bearing life adjustment evaluation for grease lubrication is not given since other factors must be considered, including bearing load, humidity conditions, service life required and frequency of re-lubrication.

Bearing lubricants basically are used to:

- Provide a minimum lubricant film thickness that will separate the contacting surfaces at bearing operating temperature and speed
- Reduce friction and thus prevent wear
- Dissipate heat generated within the bearing
- Protect the contacting surfaces from corrosion within the bearing
- Remove or seal out foreign material from the bearing

To select an adequate bearing lubricant, it is necessary to be familiar with the environment in which the bearing will operate. Lubricant selection is influenced by:

- Bearing operating temperatures
- Bearing operating speeds
- Lubrication requirements of related components
- Compatibility with sealing devices
- Method and amount of lubrication required for the bearing

Oil Vs. Grease

Lubricants for roller bearings in commercial applications are of two basic types, oil or grease. While oil is the preferred lubricant because it has the desirable characteristics of a fluid, both have their advantages and limitations:

Oil

- Suitable for all speeds—but must be used for extremely high speeds
- For elevated temperatures—where the oil is circulated to cool the bearing
- For extremely low temperatures
- To provide a clean, filtered environment
- For a closed lubrication system—where related components require lubrication in addition to the bearings
- For critical applications—where the quantity of the lubricant must be controlled
- For more positive feeding of lubricant to heavily loaded contact surfaces
- For low running torque condition use an oil mist lubrication system

Grease

- For extremely low to moderate speeds
- For low to moderate loads
- For moderate temperatures
- As an aid in excluding severe contamination because of its consistency
- For less complicated lubrication systems
- For simple, positive lubrication as in a self-contained, sealed, pre-lubricated unit
- For a simplified housing design
- For ease of sealing

Oil

Oil, the preferred lubricant for roller bearings, consists of either petroleum fluids refined from crude oil or synthetic fluids produced by chemical synthesis. Most commercial lubricating oils are available with an additive or combination of additives to meet various environmental or operating conditions. Common types of additives and their primary functions are:

- **Oxidation inhibitor:**
Retards oil deterioration and formation of sludge, carbon and varnish
- **Rust inhibitor:**
Protects lubricated surfaces from rust and corrosion
- **Detergent—dispersant:**
Reduces and controls degradation products and helps maintain cleanliness of lubricated surfaces
- **Defoaming agent:**
Prevents formation of air bubbles
- **Extreme Pressure (EP) additive:**
Prevents high friction, wear or scoring under various conditions of sliding or marginal lubrication
- **Viscosity Index (VI) improver:**
Reduces the affect of temperature changes on oil viscosity
- **Pour—Point Depressant:**
Lowers the solidification point of oil

The above list is not meant to imply that all or any of these specific additives mentioned are always required. Proper use of additives is fundamental to obtaining long and satisfactory roller bearing service. It is recommended that a reputable oil company be consulted for the specific operating conditions under consideration. Special attention should be given to stability over the operating temperature range of the oil and to possible chemical changes in the oil from storage or service conditions.

The oil lubrication systems most commonly used in commercial applications are:

- **Splash Feed System.** In many transmission and gear box systems, sufficient splash is generated by the gears to lubricate the bearings. However, if excessive contaminants are generated by the gears or if the system cannot be cleaned frequently, contaminants may cause serious damage to the bearings. It is recommended that magnetic drain plugs be used in these systems.
- **Oil Circulating System.** This system is used for the same speed ranges as the Oil Drop Feed System. However, it is designed for use when excessive heat or contamination must be removed from the bearing. To meet the contamination problem, a suitable filter should be incorporated into the system.
- **Oil Mist System.** This system is recommended for use when the speeds are extremely high, provided the air which atomizes the oil is clean and dry.
- **Constant Oil Level.** In low and medium speed applications, a constant oil level system is used. The oil level should immerse approximately fifty percent of the lowest roller when the bearing is stationary.
- **Drop Feed System.** When the speed is too high for the oil level system, the drop feed system is often used. In this case, the oil is fed into the bearing in droplet form. It moves through the bearing and out the drain, which is located on the side opposite the oil supply. It is not recommended where contamination is a problem or where good cooling is required.

Grease

Greases in general use for roller bearings are composed of oil thickened with a metallic soap base, in various proportions, to form a desired consistency. The oil is of a specified viscosity no lower than 70 SUS (Saybolt Universal Seconds) at 100° F. The soap base type may be sodium (soda), calcium (lime), lithium, calcium complex, aluminum complex or various synthetic and non-soap base types. Properties of some of the soap base types are:

- **Sodium**—good stability at the higher permissible speed and temperature ranges; not water resistant
- **Calcium**—inexpensive; good water resistance; limited to temperatures under 150° F.
- **Lithium**—generally stable at higher temperatures, good water resistance, good internal cohesion, “multi-purpose”.

Sodium and mixed sodium-calcium soap greases are considered good “general purpose” lubricants. Calcium, lithium and non-soap greases are used where water resistance is required.

Synthetic oil greases are more expensive than petroleum oil greases and are used where it is desirable to broaden the temperature range beyond that of petroleum base greases.

- Silicone oil greases are used for both high and low temperature operation (-100° F to +450° F), but have a limited load carrying capacity
- Ester oil greases cover a wide temperature range (-100° to +350° F)
- Di-ester oil greases cover the low temperature range to -65° F

The grease consistency at bearing operating temperature is an important factor in selecting a suitable grease. Its melting point should be considerably higher than the operating temperature. Roller bearing greases in general use are a NLGI #1 or #2 grade, multipurpose, with an ASTM worked penetration number between 265-340.

The following guide applies to general applications under normal loading at operating speeds of 100—1000 rpm. For heavy loads and low speeds, the advice of a lubrication engineer should be obtained.

**TABLE 8
GREASE TEMPERATURE GUIDE**

Grease Grade	Operating Temperature
#0	Below 32° F
#1	32° F—150° F
#2	150° F—250° F

**TABLE 9
GREASE CONSISTENCY CLASS**

Grease Grade	ASTM Worked Penetration @ 77° F	Description
#0	355—385	Very soft
#1	310—340	Soft
#2	265—295	Moderately firm

Grease churns when used in excessive quantities, resulting in excessive temperatures, separation of the grease components and breakdown in the lubricant. Generally, the cavity in which the bearing is mounted should be kept 1/2—1/3 full for normal speeds.

A suitable grease should remain mechanically and chemically stable at operating temperature. It should not thicken, harden, separate, or become acid or alkaline to any marked degree.

Re-lubrication intervals should be established based on the experience of similar applications. The recommended grease type should be used.

HANDLING AND INSTALLATION

Improper handling practices prior to and during installation can easily damage the quality and precision built into NTN-Bower roller bearings. Although a general set of rules cannot adequately cover all the ways that a roller bearing should be handled to prevent it from becoming unserviceable, certain essential precautions and care will minimize such damage.

Prior to shipment, NTN-Bower roller bearings are thoroughly cleaned, coated with a rust preventative, and carefully packaged for protection against contamination and oxidation. A positive effort should be made to keep the bearings in this condition prior to final assembly. The bearing package should be kept closed until ready for immediate installation. If it is necessary to unwrap the bearings before that time, they should be placed on a clean surface and covered with a lint free cloth. Prior to bearing installation, housings, shafts, and other adjacent parts should be wiped clean or washed. In addition, foundry sand should be completely removed from castings.

Roller bearings should be installed in an area where a clean atmosphere exists. In addition, it is imperative that assembly benches and tools be kept clean to prevent contaminants such as dust, grit and steel chips from entering the bearing. Contamination not only causes rough and noisy operation, but usually results in premature bearing fatigue. It is much easier to keep a bearing clean than it is to wash it clean enough for service.

New bearings must be cleaned prior to installation only if they become contaminated after being removed from their original package. Light spindle oils (less than SAE 10 Viscosity) or Stoddard solvents are recommended for washing purposes. It is recommended that chlorinated solvents not be used because of rust hazards associated with certain types. Compressed air may be used to blow out foreign matter. However, care must be taken not to free spin the bearing because permanent damage may result from dirt particles scoring the rolling surfaces. The compressed air must be filtered so that it is free from moisture, otherwise it could corrode the bearing surfaces.

The bearings must be carefully inspected after cleaning to make certain they are clean enough for use. They should then be coated with a rust preventative and installed immediately or wrapped in a grease proof paper and properly labeled for future identification.

The bearing mounting must be properly designed from a functional standpoint and must have correct shaft and housing fits and shoulder heights. In addition, the design should be such that the bearings and other components can be installed as easily as possible.

Proper assembly tools such as arbor presses, pullers, and sleeves will not only facilitate assembly, but will also avoid damage to the bearings. When a roller bearing is pressed on a shaft, the inner ring must be started squarely. A "cocked" ring may score the shaft and damage the bearing. The pressure must be applied directly on the ring being pressed, avoiding all pressure through the rollers. The bearing must not be tapped in place with direct blows on the bearing ring. The preferred practice is to place a sleeve between the bearing ring and the hammer and to tap the sleeve lightly all around. Hammers that shed chips should not be used as the chips may get into the bearing recesses.

Sometimes a bearing must be heated so that it can be more easily assembled on a shaft. A convenient method of doing this is to insert a heat source such as an electric light bulb in the bore of the bearing, keeping it there until the inner ring has expanded sufficiently. Another method is to heat the bearing in a bath of hot oil. The oil must be clean and the temperature should not exceed 250° F. Higher temperatures may cause the oil to decompose and the bearing to lose its proper hardness.

Further information regarding the care and installation of roller bearings may be obtained from the NTN Application Engineering Department.

Cylindrical Roller Bearings

Cylindrical roller bearings are manufactured by NTN-Bower in several series that differ in proportion, width, and load rating. Bore size for each series increases in multiples of five or more millimeters and for each bore size a selection of different narrow and wide series is available to meet the needs of most applications. External dimensions and tolerances conform to RBEC #1 metric bearing standards as defined in the American Bearing Manufacturers Association (ABMA) and American National Standards Institute (ANSI).

NTN-Bower standard product lines include two basic series: the “M” series for light and medium radial loads and the “W” series for heavy to extra heavy radial loads. Only complete bearing assemblies interchange between the Max-Pak and the “M” series bearings; separable rings and roller assemblies do not.

The “W” (Max-Pak) series provides an average radial load rating increase of 20 percent and a life increase of 80 percent. These increases are possible by reducing the wall thickness of the bearing rings. This reduction provides additional space for larger rollers resulting in higher calculated ratings.

While cylindrical roller bearings are designed primarily for high radial loads, certain types are capable of handling light and intermittent thrust loads, which also permits them to be used for axial shaft location.

The cylindrical roller bearing is a nonadjustable design. The correct radial internal clearance is built in at time of manufacture; when properly installed, the bearing has the correct running clearance. By using an “A” style outer ring, a press fit for the outer ring is obtained when installed in a housing previously designed to produce a tap fit.

NTN-Bower also manufactures a limited number of specialty bearings that include the “MOJ” and “MOX” style, custom “R” series, mast and chain guide bearings. A part number listing, dimensional data and load ratings can be found in the special bearing section of this catalog on page 72.

Radial Section Comparison

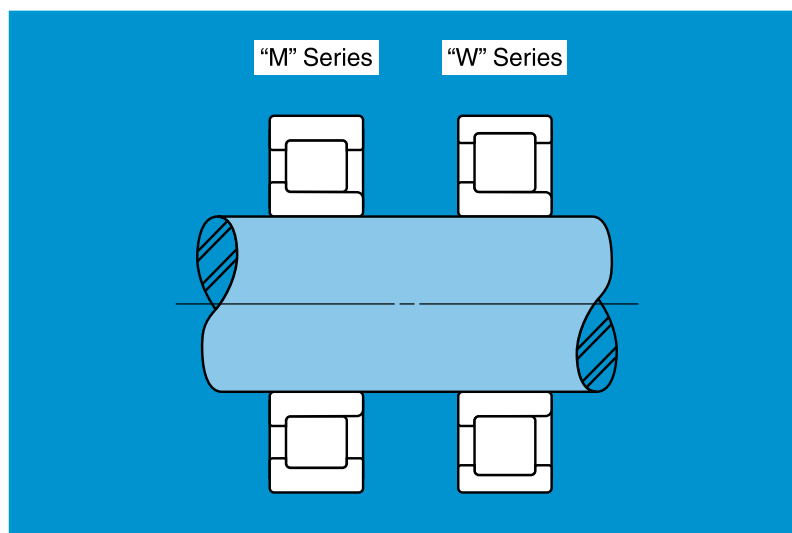

Bearing Design

“M” SERIES BEARINGS

The “M” series designated by the prefix letter “M” satisfies most commercial applications and is available in a broad range of sizes and types up to 20” (508 mm) outside diameter. This series is available with several types of cages including composite steel, “X” bar, stamped steel, and *Fibron. This series is also available with a full complement of rollers (i.e., no cage).



“W” (MAX-PAK) SERIES BEARINGS

The Max-Pak series with the prefix letter “W” interchanges with the “M” series and is designed for applications with very heavy radial loads. This series can be produced in most of the same types and sizes as the “M” series and is available with an “X” bar steel or stamped steel cage.

“A” style (oversize outer ring for heavy press fit in a standard size housing bore) is the standard Outside Diameter for the Max-Pak series.

For individual part number availability, contact NTN Sales.



Series Interchange

M Series	Max-Pak
M1900	W61900
M1000	W61000
M1200	W61200
M5200	W65200
M1300	W61300
M7300	W67300

****“Fibron” is the NTN—Bower trade name for nonmetallic cages**

Bearing Design

CAGES

“M” series bearings are supplied with one of four basic cage styles; composite steel, one piece steel, “X” bar, and Fibron. Bearing load ratings for various cage styles are included in the “Dimensions and Load Ratings” section of this catalog. Load ratings for bearings using Fibron cages are the same as the column for inner ring assemblies with one-piece steel cages.

The composite steel cage provides more rollers for a given bearing size than is possible with other designs to offer greater radial load carrying capacity. Guidance for this cage is located on the ground ribs of the ring containing the rollers.

The one piece steel cage provides a maximum number of equally spaced rollers for a given bearing size. This cage is simple, light weight and exceptionally strong. Its open construction permits free flow of lubricant through the bearing, which is especially important for relatively high temperature and high speed applications.

The “X” bar steel cage offers line contact at four locations to each roller resulting in superior roller guidance. This can allow for higher rotational speeds and greater running accuracy.

MATERIAL

Both rings and rollers of NTN-Bower cylindrical roller bearings are made from case hardened alloy steel of “Bearing Quality” to provide maximum fatigue life and reliability. Precise control of heat treatment, dimensions, and surface finish of the components further contribute to reliable bearing performance.

CROWNED ROLLERS

NTN-Bower’s pioneering efforts in developing crowned rollers for cylindrical roller bearings have resulted in greater load carrying capacity and substantially longer bearing life. Crowned rollers, under load, distribute stress equally along their full length of contact with the raceways, thereby eliminating stress concentration at the roller ends. This design concept also compensates for minor misalignment between shaft and housing bores and deflections under load by reducing stress concentrations.

Crowned rollers are manufactured in two basic profiles. A full crown roller is used in small size bearings or in applications where high misalignment is expected and a modified “dubbed” crown in the large size bearings.



X BAR STEEL CAGE



FIBRON CAGE



**ONE PIECE
STEEL CAGE**



COMPOSITE STEEL CAGE

(This page left intentionally blank.)

Numbering System

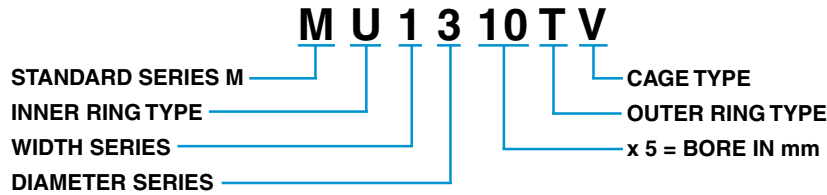

PREFIX LETTERS

1	2	3	4	
C	A			Plain Inner Ring
		B		Special Features
			C	Mast and Chain Guide Bearings
			D	Special Features
			D	Inner Ring Bore 5mm Undersize (Max-Pak Series Only)
			E	Inner Ring Bore 10mm Undersize (Max-Pak Series Only)
M		F		Inner Ring Bore 15mm Undersize (Max-Pak Series Only)
			G	Unground Rib O.D.
			G	Inner Ring Bore 20mm Undersize (Max-Pak Series Only)
		N	N	Standard Metric Series
			N	Inner Ring Plate
		R		Custom Series
R		R		One Ribbed Inner Ring
		S		Short, One Ribbed Inner Ring
		T	T	5mm or 10mm Undersize Bore
W		U		Two Ribbed Inner Ring
		X		Max-Pak 60000 Series
		X		Unground Rib O.D.

SUFFIX LETTERS

1	2	3	4	5	
	A	A			Oversized O.D. for Heavy Press Fit in Standard Housing Bore
	B	B	B		Special Features
C	C	C			Plain Outer Ring
D	D				One Ribbed Outer Ring
E	E				Two Ribbed Outer Ring
F	F	F	F	F	Unground Rib I.D.
G	G	G			Fibron Cage
	H	H			Snap Ring Groove in Outer Ring O.D.
J	J	J	J	J	Blind Dowel Hole in Outer Ring O.D.
L	L	L	L	L	Brass or Bronze Cage
	M	M	M	M	Composite Steel Cage
	N	N			Full Complement Bearing (No Cage)
			R	R	Outer Ring Plate
S					Snap Ring Assembled in Outer Ring O.D.
T	T	T			Short, One Ribbed Outer Ring
U	U				Two Retaining Rings in Outer Ring I.D.
V	V	V	V	V	One Rib, One Retaining Ring in Outer Ring I.D.
X					One Piece Steel Cage
X	X	X	X	X	Unground Rib I.D.
					"X" Bar Composite Steel Cage

INNER RING TYPES

Prefix Letters

A R N S U

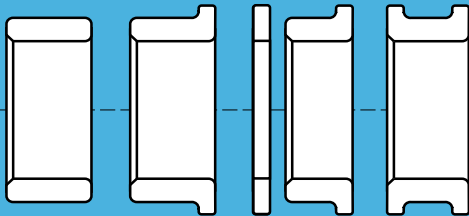

OUTER RING TYPES

Suffix Letters

C D E S N T U

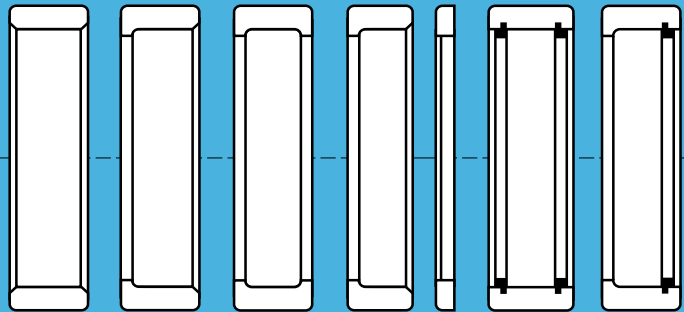

Nomenclature

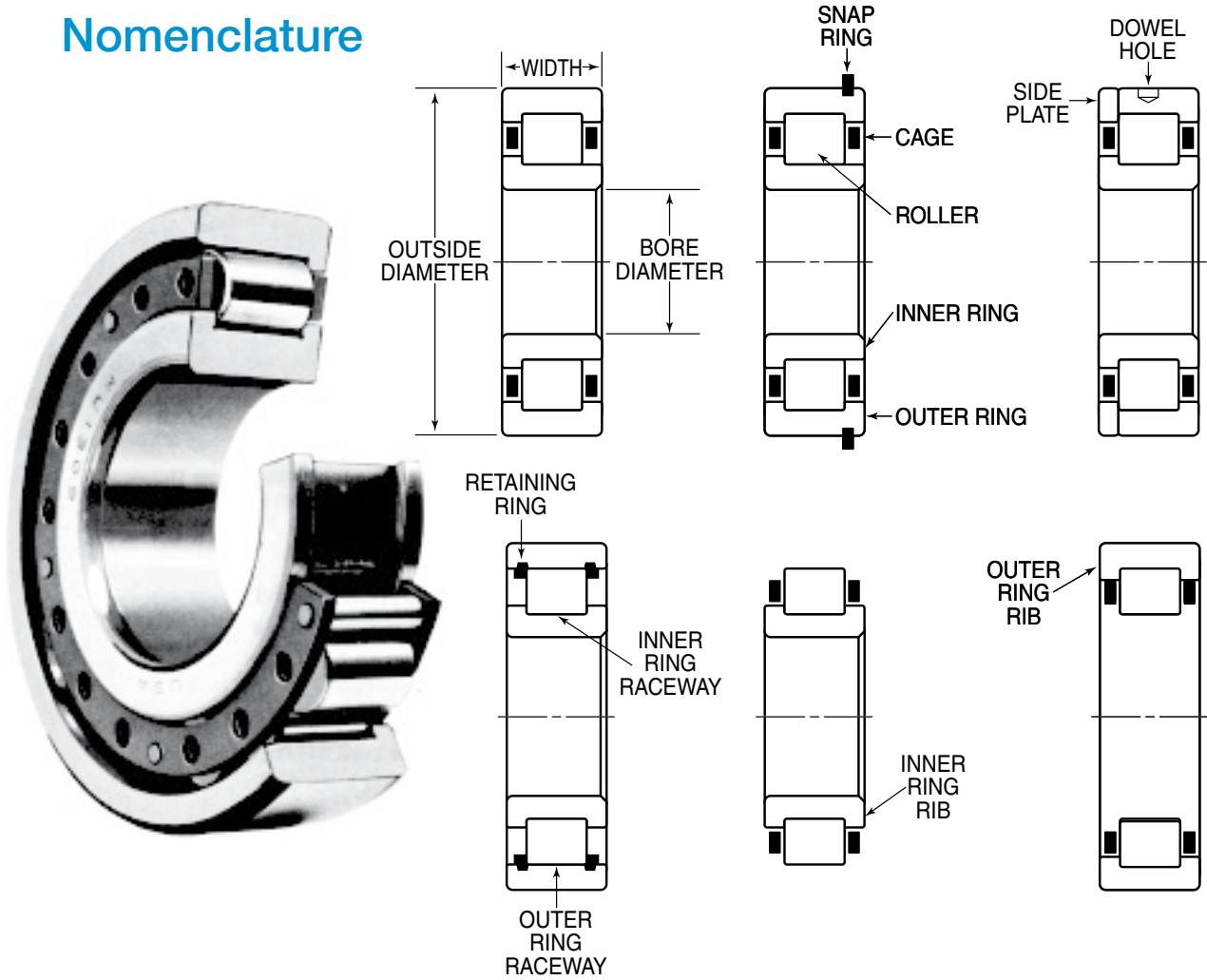

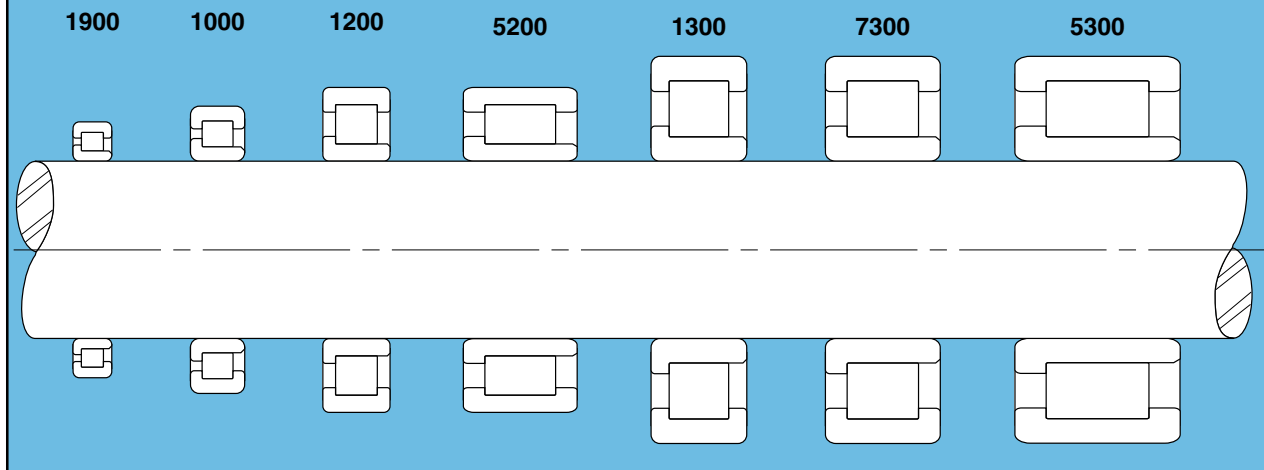

RELATIVE BEARING SIZES

Seven M series bearings having the same bore size.





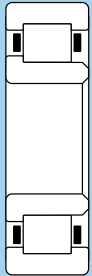
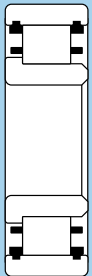

Bearing Types

SEPARABLE INNER RINGS

 <p>MA---EL</p>	<p><u>Design Features</u></p> <ul style="list-style-type: none"> • Two ribbed outer ring. • Straight, separable inner ring. • Rollers retained with outer ring. • Composite steel cage. <p><u>Application</u></p> <ul style="list-style-type: none"> • Permits axial float of shaft. • Accomodates contraction or expansion at one end of a shaft. Bearing at opposite end locates shaft.
 <p>MA---TV</p>	<p><u>Design Features</u></p> <ul style="list-style-type: none"> • Two split retaining rings in outer ring. • Straight, separable inner ring. • Rollers retained with outer ring. • One-piece steel cage. <p><u>Application</u></p> <ul style="list-style-type: none"> • Permits axial float of shaft. • Low cost bearing type. • Accomodates contraction or expansion at one end of a shaft. Bearing at opposite end locates shaft.
 <p>MR---EL</p>	<p><u>Design Features</u></p> <ul style="list-style-type: none"> • Two ribbed outer ring. • One ribbed, separable inner ring. • Rollers retained with outer ring. • Composite steel cage. <p><u>Application</u></p> <ul style="list-style-type: none"> • Takes moderate thrust loads or locates shaft in one direction only. • When used in pairs on a common shaft, thrust loads can be taken or shaft located in either direction.
 <p>MR---TV</p>	<p><u>Design Features</u></p> <ul style="list-style-type: none"> • Two split retaining rings in outer ring. • One ribbed, separable inner ring. • Rollers retained with outer ring. • One-piece steel cage. <p><u>Application</u></p> <ul style="list-style-type: none"> • Outer ring is located, axially, in one direction by inner ring rib. Location in opposite direction must be provided for. • Rib on inner ring can be used to facilitate its removal from shaft. • Will not accomodate thrust loads or locate shaft.

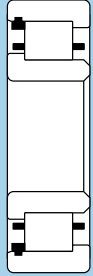

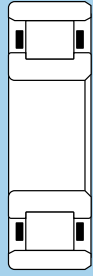
Bearing Types

SEPARABLE INNER RINGS (continued)

 <p>MR---UV</p>	<p><u>Design Features</u></p> <ul style="list-style-type: none"> • One split retaining ring and one rib in outer race. • One ribbed, separable inner ring. • Rollers retained with outer ring. • One-piece steel cage. <p><u>Application</u></p> <ul style="list-style-type: none"> • Takes moderate thrust loads or locates rotating member in one direction. • When used in pairs on a common shaft, thrust loads can be taken or shaft located in either direction.
 <p>MSN---EL</p>	<p><u>Design Features</u></p> <ul style="list-style-type: none"> • Two ribbed outer ring. • Removable, short, one ribbed inner ring and loose side plate. • Rollers retained with outer ring. • Composite steel cage <p><u>Application</u></p> <ul style="list-style-type: none"> • Takes moderate thrust loads or locates rotating member, axially, in both directions. • Bearing can be installed separately or as a unit.
<h3>SEPARABLE OUTER RINGS</h3>	
 <p>MU---CL</p>	<p><u>Design Features</u></p> <ul style="list-style-type: none"> • Straight, separable outer ring. • Two ribbed inner ring. • Rollers retained with inner ring. • Composite steel cage <p><u>Application</u></p> <ul style="list-style-type: none"> • Permits axial float of shaft like MA—EL but rollers are retained with inner ring; desirable for some applications. • Straight outer ring design is ideal for oil flow and purging contaminants.
 <p>MU---CV</p>	<p>Same design features and application as described above for MU—CL, except uses one-piece steel cage.</p>

Bearing Types

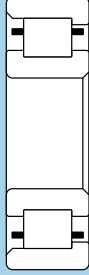
SEPARABLE OUTER RINGS (continued)

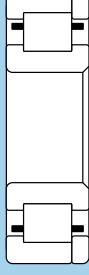
 <p>MU---DL</p>	<p><u>Design Features</u></p> <ul style="list-style-type: none"> • One ribbed, separable outer ring. • Two ribbed inner ring. • Rollers retained with inner ring. • Composite steel cage. <p><u>Application</u></p> <ul style="list-style-type: none"> • Takes moderate thrust loads or locates shaft in one direction only. • When used in pairs on common shaft, thrust loads can be taken or shaft located in either direction.
 <p>MU---DV</p>	<p>Same design features and applications as MU—DL above, except uses one-piece steel cage.</p>
 <p>MU---SNL</p>	<p><u>Design Features</u></p> <ul style="list-style-type: none"> • Removable, short, one ribbed outer ring and loose side plate. • Two ribbed inner ring. • Rollers retained with inner ring. • Composite steel cage <p><u>Application</u></p> <ul style="list-style-type: none"> • Takes moderate thrust loads or locates rotating members axially in both directions. • Bearing can be installed separately or as a unit.
 <p>MU---SNV</p>	<p>Same design features and application as MU—SNL above except uses one-piece steel cage.</p>

Bearing Types

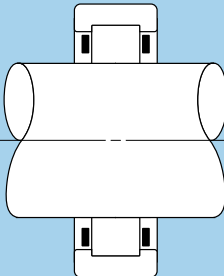
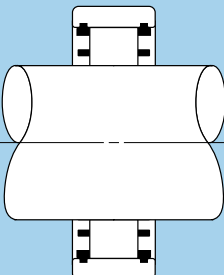
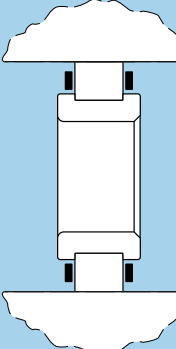
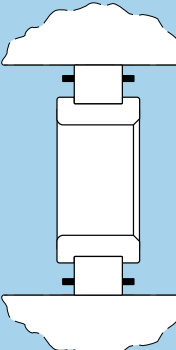

INNER OR OUTER RING OMITTED

 <p>M---EL</p>	<p><u>Design Features</u></p> <ul style="list-style-type: none"> • Two ribbed outer ring. • Inner ring omitted. • Composite steel cage. 	<p><u>Application</u></p> <ul style="list-style-type: none"> • Where mounting space is limited, rollers run directly on a hardened and ground shaft.* • Shaft diameter can be increased to replace omitted outer ring for added stiffness. • Savings are possible by using a smaller bearing and eliminating inner ring.
 <p>M---TV</p>	<p><u>Design Features</u></p> <ul style="list-style-type: none"> • Two split retaining rings in outer ring. • Inner ring omitted. • One-piece steel cage. 	<p><u>Application</u></p> <ul style="list-style-type: none"> • Use is similar to M—EL above.
 <p>MU---L</p>	<p><u>Design Features</u></p> <ul style="list-style-type: none"> • Outer ring is omitted. • Two ribbed inner ring. • Composite steel cage. 	<p><u>Application</u></p> <ul style="list-style-type: none"> • Where space is limited, housing bore can be reduced—permitting rollers to run directly on hardened and ground housing bore.* • Shaft diameter can be increased for added stiffness by eliminating outer ring and using next larger size bearing bore. Housing bore is modified to suit diameter over the rollers. • Savings are possible through eliminating outer ring.
 <p>MU---V</p>	<p>Same design features and application as MU—L above except bearing uses one-piece steel cage.</p>	

*Note: Shaft or housing bore surfaces functioning as bearing raceways must have a hardness of Rockwell C58 to C64 and a maximum surface finish of 18 AA. Deviation from this surface finish or hardness will require a reduction in the catalog rating of the bearing. Consult NTN Engineering for a recommendation.

Bearing Types

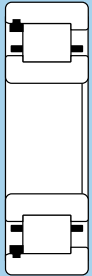
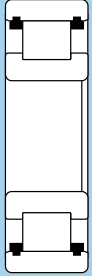
NON-SEPARABLE BEARINGS

 <p>MU----TV</p>	<p><u>Design Features</u></p> <ul style="list-style-type: none"> • Two split retaining rings in outer ring. • Two ribbed inner ring. • One-piece steel cage. <p><u>Application</u></p> <ul style="list-style-type: none"> • Used where bearing must be assembled as a unit and where design has no provision to retain outer ring axially. • Will not accommodate thrust loads or locate shaft.
 <p>MU----UV</p>	<p>Same design features and applications as MU—TV above, except outer ring contains one split retaining ring and one solid rib which will take moderate thrust loads or locate shaft in one direction.</p>
 <p>MU----TM</p>	<p><u>Design Features</u></p> <ul style="list-style-type: none"> • Two split retaining rings in outer ring. • Two ribbed inner ring. • No cage (full complement of rollers). <p><u>Application</u></p> <ul style="list-style-type: none"> • Use is similar to MU—TV above. • Cage is omitted and rollers are added for increased radial load capacity. Permissible bearing speed, however, is less than the caged type bearing.
 <p>MU----UM</p>	<p>Same design features and application as MU—TM above except outer ring contains one split retaining ring and one solid rib that will take a moderate thrust load or locate shaft in one direction.</p>

Interchange Charts for Basic Series*

SEPARABLE INNER RING TYPE BEARINGS

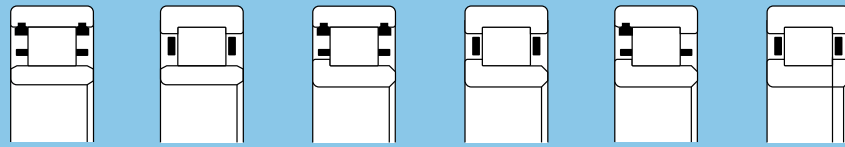

BOWER	MA---TV	MA---EL	MR---TV	MR---EL	MR---UV	MSN---EL
AFBMA	--RM--	--RU--	--RR--	--RJ--	--RS--	--RT--
FAG		NU--		NJ--		NUP--
HYATT	A---TS	A---WB	R---TS	R---WB	R---YS	JRN---WB
LINK BELT	MA---TV	MA---EX	MR---TV	MR---EX	MR---UV	MSN---EX
ROLL WAY	E---B	E---U	L---B	L---U	L---J	LP---U
SKF	HNU---A		HNJ---A			
NTN		NU--		NJ--		NUP--

SEPARABLE OUTER RING TYPE BEARINGS

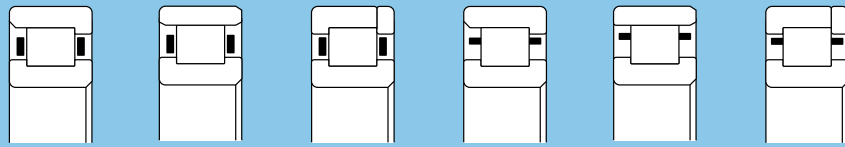

BOWER	MU---DL	MU---CL	MU---SNL	MU---DV	MU---CV	MU---SNV
AFBMA	--RF--	--RN--	--RP--	--RF--	--RN--	--RP--
FAG	NF---	N---		NF--	N---	
HYATT	BU---L	BU---Z	BU---LNJ	BU---L	BU---Z	BU---LNJ
LINK BELT	MU---DX	MU---CX	MU---SNX	MU---DX	MU---CX	MU---SNX
ROLL WAY	U---L	U---E	U---LP	U---L	U---E	U---LP
SKF						
NTN	NF--	N--	NP--	NF--	N--	NP--

NON-SEPARABLE TYPE BEARINGS

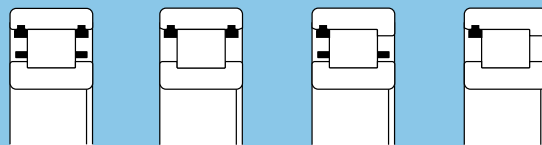

BOWER	MU---TV	MU---TM	MU---UV	MU---UM
AFBMA	--RK--	--RK--V	--RY--	--RY--V
FAG				
HYATT	U---TS	U---TM	U---YS	U---YM
LINK BELT	MU---TV	MU---TM	MU---UV	MU---UM
ROLL WAY	U---B	UM---B	U---J	UM---J
SKF	HNC---A	HNC---AV		
NTN		NV--		

* Charted bearings interchange for boundary dimensions (I.D., O.D., width) and bearing types. They may not interchange due to differences in load ratings or cage styles.

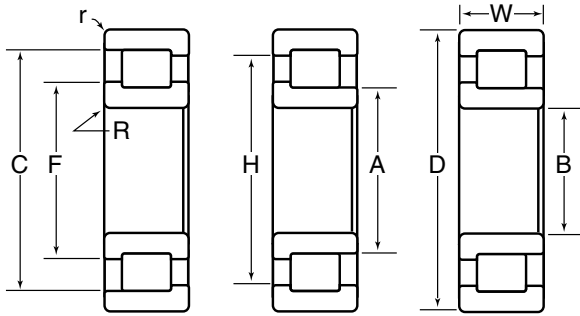

DIMENSIONS

The basic boundary dimensions (bore, outside diameter, width) in the following tables conform to the standards established by ABMA/ANSI.

A description of dimensions represented by various letters is given below:

- B** Maximum bearing bore diameter. The minus tolerance is given on page 79 and the range in "Fitting Practice" section
- D** Maximum bearing O.D. The minus tolerance is given on page 79 and the range in "Fitting Practice" section
- W** Maximum bearing width. The minus tolerance is given on page 79.
- A** Maximum O.D. of the inner ring raceway
- C** Minimum I.D. of the outer ring raceway
- F** Maximum rib O.D. of the inner ring
- H** Minimum rib I.D. of the outer ring
- R** Maximum fillet on the shaft that the bearing corner will clear
- r** Maximum fillet in the housing that the bearing corner will clear

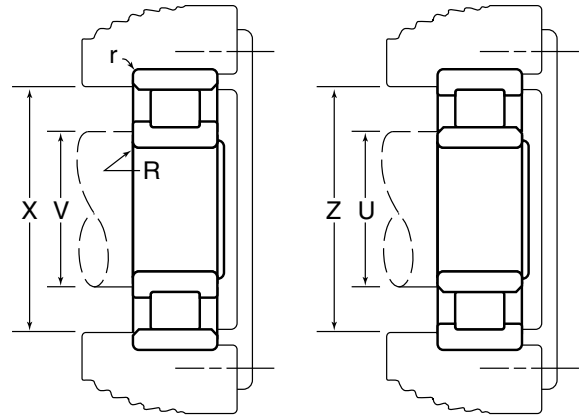

- X** Recommended maximum housing shoulder diameter for plain outer rings
- V** Recommended minimum shaft shoulder diameter for ribbed inner rings
- Z** Recommended maximum housing shoulder diameter for ribbed outer rings
- U** Recommended minimum shaft shoulder diameter for plain inner rings

Dimensions shown in tables are given in both inch and metric units and are based on:

- 1 inch = 25.4 mm exactly
- 1 micrometer = 1 μ m = 10⁻⁶m
- 1 micrometer = .001 mm

LOAD RATINGS

The radial load ratings in this catalog are based on 500 hrs L₁₀ life at 33 $\frac{1}{3}$ rpm or 1 million cycles for either inner or outer ring rotation. To convert this rating to 3000 hrs L₁₀ life at 500 rpm or 90 million cycles basis, divide by 3.857.

The load ratings, dynamic and static, are shown in both pounds and newtons, i.e.,

- 1 pound = 4.448 newtons

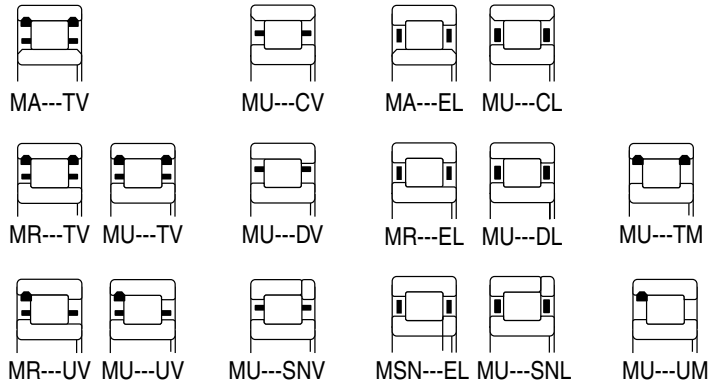
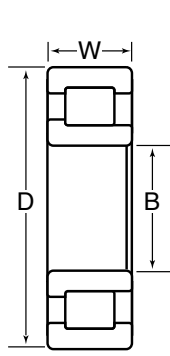

Basic Bearing Number	B	D		W	Radial Load Ratings — lbs./N											
		Bore Diameter	Outside Diameter		One Piece Steel Cage				Composite Steel Cage		X Bar Steel Cage		Full Complement (No Cage)			
	Inch/mm		Standard Style	"A" * Style	Width	Outer Ring Assemblies		Inner Ring Assemblies		Dynamic	Static	Dynamic	Static	Dynamic	Static	Dynamic
		Dynamic	Static	Dynamic		Static	Dynamic	Static	Dynamic							
1203	0.6693 17.000	1.5748 40.000	1.5758 40.025	0.4724 12.000	3950 17500	3300 14700										
1204	0.7874 20.000	1.8504 47.000	1.8514 47.026	0.5512 14.000	4500 20100	4100 18300										
5204	0.7874 20.000	1.8504 47.000	1.8514 47.026	0.8125 20.638	7400 33000	7750 34500						7800 34500	8350 37000	9000 40000	10100 45000	
1304	0.7874 20.000	2.0472 52.000	2.0482 52.024	0.5906 15.000	5950 26400	5150 22900			6350 28100	5600 24900						
7304	0.7874 20.000	2.0472 52.000	2.0482 52.024	0.7087 18.000												
5304	0.7874 20.000	2.0472 52.000	2.0482 52.024	0.8750 22.225	9150 41000	8950 40000										
1205	0.9843 25.000	2.0472 52.000	2.0482 52.024	0.5906 15.000	5700 25400	5750 25600	5700 25400	5750 25600	6300 28100	6600 29300	6300 28100	6600 29300	7200 32000	7800 35000		
5205	0.9843 25.000	2.0472 52.000	2.0482 52.024	0.8125 20.638					8600 38500	9750 43500			9800 43500	11600 51500		
1305	0.9843 25.000	2.4409 62.000	2.4421 62.029	0.6693 17.000	8000 35500	7000 31000	8000 35500	7000 31000	8550 38000	7650 34000			9600 42500	8900 39500		
7305	0.9843 25.000	2.4409 62.000	2.4421 62.029	0.8268 21.000					11300 50500	11000 49000						
5305	0.9843 25.000	2.4409 62.000	2.4421 62.029	1.0000 25.400	12900 57000	12900 57500			13700 61000	14100 62500						
1006	1.1811 30.000	2.1654 55.000	2.1665 55.029	0.5118 13.000												
1206	1.1811 30.000	2.4409 62.000	2.4421 62.029	0.6299 16.000	7900 35000	7900 35000	7900 35000	7900 35000	8300 37000	8450 37500			9550 42500	10100 45000		
5206	1.1811 30.000	2.4409 62.000	2.4421 62.029	0.9375 23.812	11800 52500	12500 56000	12400 55500	14200 63000	12400 55500	14200 63000			14200 63000	16100 71500		
1306	1.1811 30.000	2.8346 72.000	2.8359 72.032	0.7480 19.000	10500 47000	10200 45500	10500 47000	10200 45500	11100 49500	11000 49000			12300 54500	12600 56000		
7306	1.1811 30.000	2.8346 72.000	2.8359 72.032	0.9055 23.000	13800 61500	14500 64500			14600 65000	15600 69500	13800 61500	14500 64500	16100 71500	17800 79500		
5306	1.1811 30.000	2.8346 72.000	2.8359 72.032	1.1875 23.000	15800 70500	17200 76500	16800 75000	18700 83000	17800 79000	20100 89500			19600 87500	23000 102000		
1007	1.3780 35.000	2.4409 62.000	2.4421 62.029	0.5512 14.000												

* Oversize outer ring for heavy press fit in standard housing bore.

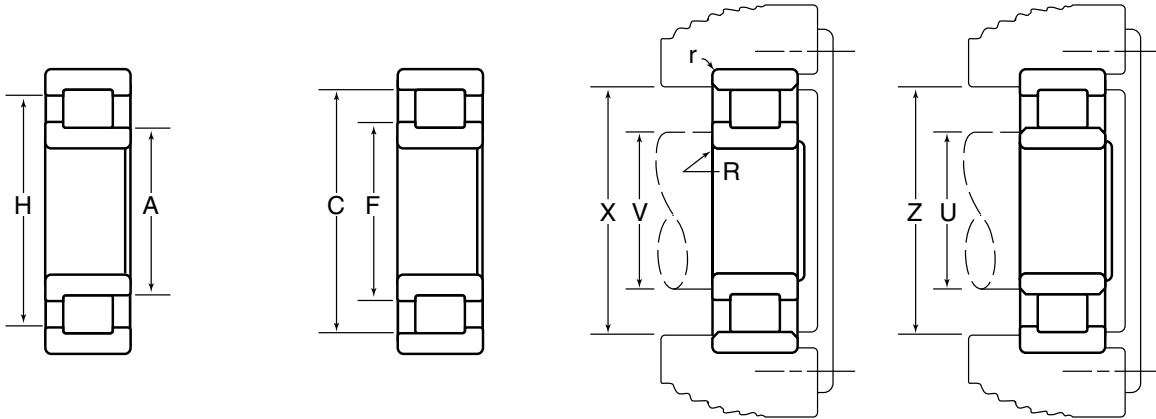

Basic Bearing Number	A	C	F	H	R	r	U	V	X	Z	Basic Bearing Number
	Inner Ring O.D.	Outer Ring I.D.	Inner Ring Rib O.D.	Outer Ring Rib I.D.	Maximum * Fillet Radius		Minimum Shaft Shoulder Diameter		Maximum Housing Shoulder Diameter		
					Shaft	Housing	Plain Rings	Rib Rings	Plain Rings	Rib Rings	
	Inch/mm										
1203	0.872 22.14	1.371 34.83	0.956 24.28	1.286 32.66	0.025 0.64	0.025 0.64	0.80 20.3	0.87 22.1	1.43 36.3	1.37 34.8	1203
1204	1.108 28.14	1.608 40.84	1.193 30.30	1.523 38.68	0.040 1.02	0.040 1.02	1.02 25.9	1.10 27.9	1.68 42.7	1.60 40.6	1204
5204	1.108 28.14	1.608 40.84	1.193 30.30	1.523 38.68	0.040 1.02	0.040 1.02	1.02 25.9	1.10 27.9	1.68 42.7	1.60 40.6	5204
1304	1.101 27.97	1.731 43.97	1.211 30.76	1.629 41.38	0.040 1.02	0.040 1.02	1.02 25.9	1.10 27.9	1.82 46.2	1.73 43.9	1304
7304	1.101 27.97	1.731 43.97	1.211 30.76	1.629 41.38	0.040 1.02	0.040 1.02	1.02 25.9	1.10 27.9	1.82 46.2	1.73 43.9	7304
5304	1.101 27.97	1.731 43.97	1.211 30.76	1.629 41.38	0.040 1.02	0.040 1.02	1.02 25.9	1.10 27.9	1.82 46.2	1.73 43.9	5304
1205	1.266 32.16	1.766 44.86	1.351 34.32	1.691 42.95	0.040 1.02	0.040 1.02	1.20 30.5	1.26 32.0	1.85 47.0	1.76 44.7	1205
5205	1.266 32.16	1.766 44.86	1.351 34.32	1.691 42.95	0.040 1.02	0.040 1.02	1.20 30.5	1.26 32.0	1.85 47.0	1.76 44.7	5205
1305	1.338 33.99	2.103 53.42	1.476 37.49	1.974 50.14	0.040 1.02	0.040 1.02	1.24 31.5	1.33 33.8	2.20 55.9	2.10 53.3	1305
7305	1.338 33.99	2.103 53.42	1.476 37.49	1.974 50.14	0.040 1.02	0.040 1.02	1.24 31.5	1.33 33.8	2.20 55.9	2.10 53.3	7305
5305	1.338 33.99	2.103 53.42	1.476 37.49	1.974 50.14	0.040 1.02	0.040 1.02	1.24 31.5	1.33 33.8	2.20 55.9	2.10 53.3	5305
1006	1.451 36.86	1.909 48.49	1.551 39.40	1.810 45.97	0.040 1.02	0.040 1.02	1.38 35.1	1.45 36.8	1.98 50.3	1.90 48.3	1006
1206	1.499 38.07	2.129 54.08	1.609 40.87	2.027 51.49	0.040 1.02	0.040 1.02	1.42 36.1	1.49 37.8	2.22 56.4	2.12 53.8	1206
5206	1.499 38.07	2.129 54.08	1.609 40.87	2.027 51.49	0.040 1.02	0.040 1.02	1.42 36.1	1.49 37.8	2.22 56.4	2.12 53.8	5206
1306	1.602 40.69	2.378 60.40	1.742 44.25	2.239 56.87	0.060 1.52	0.040 1.02	1.49 37.8	1.60 40.6	2.52 64.0	2.37 60.2	1306
7306	1.602 40.69	2.378 60.40	1.742 44.25	2.239 56.87	0.060 1.52	0.040 1.02	1.49 37.8	1.60 40.6	2.52 64.0	2.37 60.2	7306
5306	1.602 40.69	2.378 60.40	1.742 44.25	2.239 56.87	0.060 1.52	0.040 1.02	1.49 37.8	1.60 40.6	2.52 64.0	2.37 60.2	5306
1007	1.660 42.16	2.160 54.86	1.760 44.70	2.060 52.32	0.040 1.02	0.040 1.02	1.59 40.4	1.66 42.2	2.24 56.9	2.16 54.9	1007

* The maximum fillet on the shaft or in the housing that the bearing corner will clear.

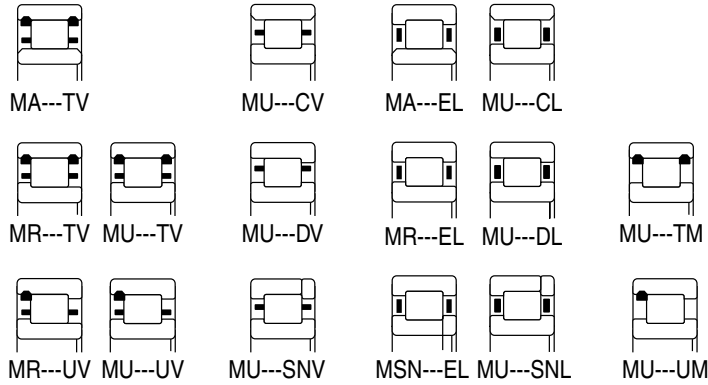
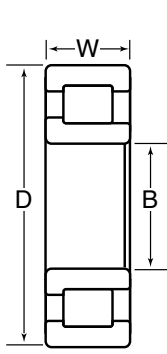

Basic Bearing Number	B	D		W	Radial Load Ratings — lbs./N											
		Outside Diameter			One Piece Steel Cage				Composite Steel Cage		X Bar Steel Cage		Full Complement (No Cage)			
	Bore Diameter	Standard Style	"A" * Style	Width	Outer Ring Assemblies		Inner Ring Assemblies		Dynamic	Static	Dynamic	Static	Dynamic	Static	Dynamic	Static
		Inch/mm			Dynamic	Static	Dynamic	Static								
1207	1.3780	2.8346	2.8359	0.6693	9050	8900	9050	8900	9550	9550	9550	9550	10900	11400		
	35.000	72.000	72.032	17.000	40500	39500	40500	39500	42500	42500	42500	42500	48500	51000		
5207	1.3780	2.8346	2.8359	1.0625	14800	16700			15600	17900	15600	17900	17800	21400		
	35.000	72.000	72.032	26.988	66000	74000			69000	79500	69000	79500	79500	95500		
1307	1.3780	3.1496	3.1510	0.8268	13200	13500	14000	14600	14000	14600	14000	14600	16200	17700		
	35.000	80.000	80.035	21.000	59000	60000	62000	65000	62000	65000	62000	65000	72000	78500		
7307	1.3780	3.1496	3.1510	1.0236					18100	20300			20900	24600		
	35.000	80.000	80.035	26.000					80500	90000			93000	110000		
5307	1.3780	3.1496	3.1510	1.3750					20800	24300			24000	29500		
	35.000	80.000	80.035	34.925					92500	108000			107000	131000		
1008	1.5748	2.6772	2.6785	0.5906												
	40.000	68.000	68.034	15.000												
1208	1.5748	3.1496	3.1510	0.7087	10800	11000	10800	11000	11300	11800	11300	11800	12900	13900		
	40.000	80.000	80.035	18.000	48000	49000	48000	49000	50500	52500	50500	52500	57000	62000		
5208	1.5748	3.1496	3.1510	1.1875	17700	20900			19600	23800	19600	23800	22300	28300		
	40.000	80.000	80.035	30.162	79000	93000			87000	106000	87000	106000	99000	126000		
1308	1.5748	3.5433	3.5449	0.9055	16700	16800	16700	16800	17600	18100	16700	16800	19500	20600		
	40.000	90.000	90.040	23.000	74000	74500	74000	74500	78500	80500	74000	74500	86500	92000		
7308	1.5748	3.5433	3.5449	1.1811					24700	27800	23300	25800	27300	32000		
	40.000	90.000	90.040	30.000					110000	124000	104000	115000	121000	141000		
5308	1.5748	3.5433	3.5449	1.4375	26400	30000	27800	32500	27800	32500	26300	30000				
	40.000	90.000	90.040	36.512	117000	134000	124000	145000	124000	145000	117000	134000				
1009	1.7717	2.9528	2.9542	0.6299			8400	10000								
	45.000	75.000	75.037	16.000			37500	44500								
1209	1.7717	3.3465	3.3480	0.7480	11900	13000	12500	13800	13000	14600	13000	14600	14600	17000		
	45.000	85.000	85.039	19.000	53000	57500	55500	61500	58000	65000	58000	65000	65000	76000		
5209	1.7717	3.3465	3.3480	1.1875					21200	27300	21200	27300				
	45.000	85.000	85.039	30.162					94500	122000	94500	122000				
1309	1.7717	3.9370	3.9388	0.9843	19600	20500	20700	22000	21800	23600	20700	22000	23900	26800		
	45.000	100.000	100.046	25.000	87000	91000	92000	98000	97000	105000	92000	98000	106000	119000		
7309	1.7717	3.9370	3.9388	1.2205					27700	32000	26300	30000	30500	36500		
	45.000	100.000	100.046	31.000					123000	143000	117000	134000	135000	162000		
5309	1.7717	3.9370	3.9388	1.5625												
	45.000	100.000	100.046	39.688												
1010	1.9685	3.1496	3.1510	0.6299			8600	10600	8600	10600						
	50.000	80.000	80.035	16.000			38000	47000	38000	47000						

* Oversize outer ring for heavy press fit in standard housing bore.

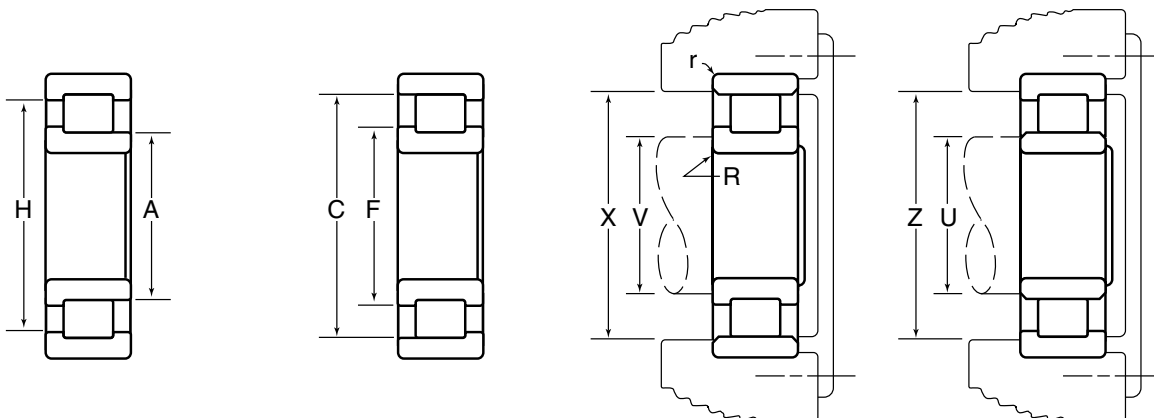

Basic Bearing Number	A	C	F	H	R	r	U	V	X	Z	Basic Bearing Number
	Inner Ring O.D.	Outer Ring I.D.	Inner Ring Rib O.D.	Outer Ring Rib I.D.	Maximum * Fillet Radius		Minimum Shaft Shoulder Diameter		Maximum Housing Shoulder Diameter		
					Shaft	Housing	Plain Rings	Rib Rings	Plain Rings	Rib Rings	
	Inch/mm										
1207	1.731 43.97	2.460 62.48	1.862 47.29	2.343 59.51	0.040 1.02	0.040 1.02	1.64 41.7	1.73 43.9	2.57 65.3	2.46 62.5	1207
5207	1.731 43.97	2.460 62.48	1.862 47.29	2.343 59.51	0.040 1.02	0.040 1.02	1.64 41.7	1.73 43.9	2.57 65.3	2.46 62.5	5207
1307	1.844 46.84	2.675 67.94	1.995 50.67	2.538 64.47	0.060 1.52	0.060 1.52	1.72 43.7	1.84 46.7	2.81 71.4	2.67 67.8	1307
7307	1.844 46.84	2.675 67.94	1.995 50.67	2.538 64.47	0.060 1.52	0.060 1.52	1.72 43.7	1.84 46.7	2.81 71.4	2.67 67.8	7307
5307	1.844 46.84	2.675 67.94	1.995 50.67	2.538 64.47	0.060 1.52	0.060 1.52	1.72 43.7	1.84 46.7	2.81 71.4	2.67 67.8	5307
1008	1.877 47.68	2.377 60.38	1.976 50.19	2.276 57.81	0.040 1.02	0.040 1.02	1.80 45.7	1.87 47.5	2.47 62.7	2.37 60.2	1008
1208	1.966 49.94	2.741 69.62	2.104 53.44	2.615 66.42	0.060 1.52	0.040 1.02	1.86 47.2	1.96 49.8	2.87 72.9	2.74 69.6	1208
5208	1.966 49.94	2.741 69.62	2.104 53.44	2.615 66.42	0.060 1.52	0.040 1.02	1.86 47.2	1.96 49.8	2.87 72.9	2.74 69.6	5208
1308	2.059 52.30	3.058 77.67	2.244 57.00	2.887 73.33	0.060 1.52	0.060 1.52	1.93 49.0	2.05 52.1	3.20 81.3	3.05 77.5	1308
7308	2.059 52.30	3.058 77.67	2.244 57.00	2.887 73.33	0.060 1.52	0.060 1.52	1.93 49.0	2.05 52.1	3.20 81.3	3.05 77.5	7308
5308	2.059 52.30	3.058 77.67	2.244 57.00	2.887 73.33	0.060 1.52	0.060 1.52	1.93 49.0	2.05 52.1	3.20 81.3	3.05 77.5	5308
1009	2.082 52.88	2.644 67.16	2.182 55.42	2.544 64.62	0.040 1.02	0.040 1.02	2.00 50.8	2.08 52.8	2.73 69.3	2.64 67.1	1009
1209	2.186 55.52	2.952 74.98	2.324 59.03	2.827 71.81	0.060 1.52	0.040 1.02	2.08 52.8	2.18 55.4	3.08 78.2	2.95 74.9	1209
5209	2.186 55.52	2.952 74.98	2.324 59.03	2.827 71.81	0.060 1.52	0.040 1.02	2.08 52.8	2.18 55.4	3.08 78.2	2.95 74.9	5209
1309	2.337 59.36	3.390 86.11	2.532 64.31	3.208 81.48	0.080 2.03	0.060 1.52	2.20 55.9	2.33 59.2	3.56 90.4	3.39 86.1	1309
7309	2.337 59.36	3.390 86.11	2.532 64.31	3.208 81.48	0.080 2.03	0.060 1.52	2.20 55.9	2.33 59.2	3.56 90.4	3.39 86.1	7309
5309	2.337 59.36	3.390 86.11	2.532 64.31	3.208 81.48	0.080 2.03	0.060 1.52	2.20 55.9	2.33 59.2	3.56 90.4	3.39 86.1	5309
1010	2.279 57.89	2.841 72.16	2.379 60.43	2.741 69.62	0.060 1.52	0.040 1.02	2.21 56.1	2.27 57.7	2.93 74.4	2.84 72.1	1010

* The maximum fillet on the shaft or in the housing that the bearing corner will clear.

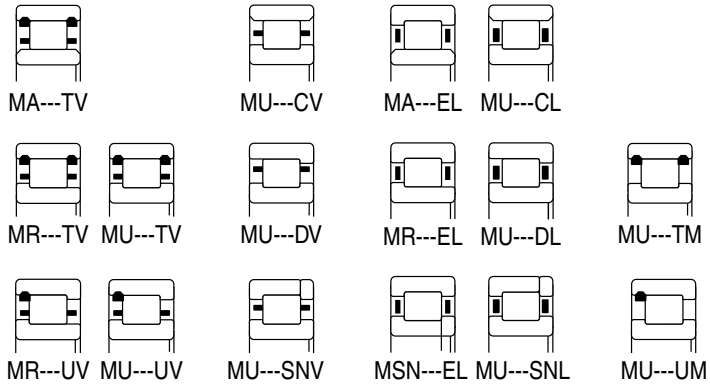
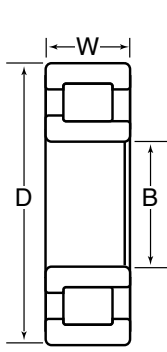

Basic Bearing Number	B			D			W			Radial Load Ratings — lbs./N						
	Bore Diameter	Outside Diameter		Width	One Piece Steel Cage				Composite Steel Cage		X Bar Steel Cage		Full Complement (No Cage)			
		Standard Style	"A" * Style		Outer Ring Assemblies		Inner Ring Assemblies		Dynamic	Static	Dynamic	Static	Dynamic	Static	Dynamic	Static
	Inch/mm			Dynamic	Static	Dynamic	Static	Dynamic	Static	Dynamic	Static	Dynamic	Static	Dynamic	Static	
1210	1.9685 50.000	3.5433 90.000	3.5449 90.040	1.7874 20.000	12700 56500	14500 64500					13200 58500	15300 68000	13200 58500	15300 68000	15200 67500	18600 82500
5210	1.9685 50.000	3.5433 90.000	3.5449 90.040	1.1875 30.162			19400 86500	25100 112000	21100 94000	28100 125000	21100 94000	28100 125000				
1310	1.9685 50.000	4.3307 110.000	4.3329 110.056	1.0630 27.000	24500 109000	26500 118000	24500 109000	26500 118000	24500 109000	26500 118000	24500 109000	26500 118000	28400 126000	32000 143000		
7310	1.9685 50.000	4.3307 110.000	4.3329 110.056	1.2992 33.000					31500 140000	36500 163000	31500 140000	36500 163000				
5310	1.9685 50.000	4.3307 110.000	4.3329 110.056	1.7500 44.450					37500 167000	46000 204000						
1911	2.1654 55.000	3.1496 80.000	3.1510 80.035	0.5118 13.000												
1011	2.1654 55.000	3.5433 90.000	3.5449 90.040	0.7087 18.000			10700 47500	13300 59500	10700 47500	13300 59500	11600 51500	14300 64000				
1211	2.1654 55.000	3.9370 100.000	3.9388 100.046	0.8268 21.000	14600 64500	16700 74000			15800 70500	18600 83000	15800 70500	18600 83000	18200 81000	22600 100000		
5211	2.1654 55.000	3.9370 100.000	3.9388 100.046	1.3125 33.338	23700 105000	31000 139000			25700 114000	35000 155000	25700 114000	35000 155000				
1311	2.1654 55.000	4.7244 120.000	4.7266 120.056	1.1417 29.000	25400 113000	26600 118000	26800 119000	28600 127000	28200 126000	30500 137000			31000 138000	35000 155000		
7311	2.1654 55.000	4.7244 120.000	4.7266 120.056	1.4173 36.000					38500 170000	45500 202000						
5311	2.1654 55.000	4.7244 120.000	4.7266 120.056	1.9375 49.212					49000 218000	62500 277000				54000 239000	70500 315000	
1912	2.3622 60.000	3.3465 85.000	3.3480 85.039	0.5118 13.000												
1012	2.3622 60.000	3.7402 95.000	3.7419 95.044	0.7087 18.000			11300 50000	14700 65000	11300 50000	14700 65000						
1212	2.3622 60.000	4.3307 110.000	4.3329 110.056	0.8661 22.000	18500 82500	20700 92000	19300 86000	21900 97500	19300 86000	21900 97500	19300 86000	21900 97500	21700 96500	25600 114000		
5212	2.3622 60.000	4.3307 110.000	4.3329 110.056	1.4375 36.512	30500 136000	39500 175000			33500 148000	44000 196000	33500 148000	44000 196000	37500 167000	51500 229000		
1312	2.3622 60.000	5.1181 130.000	5.1204 130.058	1.2205 31.000	30500 137000	33000 147000	32500 144000	35500 158000	34000 152000	38000 169000	32500 144000	35500 158000	37500 167000	43000 192000		
7312	2.3622 60.000	5.1181 130.000	5.1204 130.058	1.4961 38.000			42500 189000	50000 223000	44500 199000	53500 239000	42500 189000	50000 223000				

* Oversize outer ring for heavy press fit in standard housing bore.

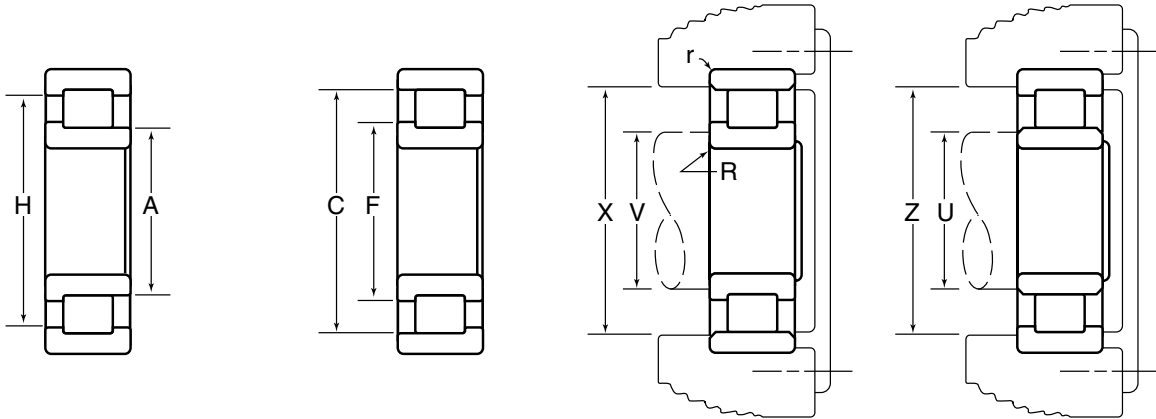

Basic Bearing Number	A	C	F	H	R	r	U	V	X	Z	Basic Bearing Number
	Inner Ring O.D.	Outer Ring I.D.	Inner Ring Rib O.D.	Outer Ring Rib I.D.	Maximum * Fillet Radius		Minimum Shaft Shoulder Diameter		Maximum Housing Shoulder Diameter		
					Shaft	Housing	Plain Rings	Rib Rings	Plain Rings	Rib Rings	
	Inch/mm										
1210	2.380 60.45	3.132 79.55	2.518 63.96	3.018 76.66	0.060 1.52	0.040 1.02	2.27 57.7	2.38 60.5	3.26 82.8	3.13 79.5	1210
5210	2.380 60.45	3.132 79.55	2.518 63.96	3.018 76.66	0.060 1.52	0.040 1.02	2.27 57.7	2.38 60.5	3.26 82.8	3.13 79.5	5210
1310	2.565 65.15	3.720 94.49	2.781 70.64	3.518 89.36	0.080 2.03	0.080 2.03	2.40 61.0	2.56 65.0	3.90 99.1	3.72 94.5	1310
7310	2.565 65.15	3.720 94.49	2.781 70.64	3.518 89.36	0.080 2.03	0.080 2.03	2.40 61.0	2.56 65.0	3.90 99.1	3.72 94.5	7310
5310	2.565 65.15	3.720 94.49	2.781 70.64	3.518 89.36	0.080 2.03	0.080 2.03	2.40 61.0	2.56 65.0	3.90 99.1	3.72 94.5	5310
1911	2.430 61.72	2.889 73.38	2.530 64.26	2.789 70.84	0.040 1.02	0.040 1.02	2.36 59.9	2.43 61.7	2.96 75.2	2.88 73.2	1911
1011	2.539 64.49	3.171 80.54	2.665 67.69	3.045 77.34	0.060 1.52	0.040 1.02	2.44 62.0	2.53 64.3	3.29 83.6	3.17 80.5	1011
1211	2.634 66.90	3.465 88.01	2.785 70.74	3.328 84.53	0.080 2.03	0.060 1.52	2.52 64.0	2.63 66.8	3.60 91.4	3.46 87.9	1211
5211	2.634 66.90	3.465 88.01	2.785 70.74	3.328 84.53	0.080 2.03	0.060 1.52	2.52 64.0	2.63 66.8	3.60 91.4	3.46 87.9	5211
1311	2.812 71.42	4.079 103.61	3.045 77.34	3.860 98.04	0.080 2.03	0.080 2.03	2.62 66.5	2.81 71.4	4.28 108.7	4.07 103.4	1311
7311	2.812 71.42	4.079 103.61	3.045 77.34	3.860 98.04	0.080 2.03	0.080 2.03	2.62 66.5	2.81 71.4	4.28 108.7	4.07 103.4	7311
5311	2.812 71.42	4.079 103.61	3.045 77.34	3.860 98.04	0.080 2.03	0.080 2.03	2.62 66.5	2.81 71.4	4.28 108.7	4.07 103.4	5311
1912	2.630 66.80	3.089 78.46	2.730 69.34	2.989 75.92	0.040 1.02	0.040 1.02	2.56 65.0	2.63 66.8	3.16 80.3	3.08 78.2	1912
1012	2.736 69.49	3.368 85.55	2.862 72.69	3.242 82.35	0.060 1.52	0.040 1.02	2.64 67.1	2.73 69.3	3.49 88.6	3.36 85.3	1012
1212	2.850 72.39	3.849 97.76	3.029 76.94	3.681 93.50	0.080 2.03	0.060 1.52	2.73 69.3	2.85 72.4	3.99 101.3	3.84 97.5	1212
5212	2.850 72.39	3.849 97.76	3.029 76.94	3.681 93.50	0.080 2.03	0.060 1.52	2.73 69.3	2.85 72.4	3.99 101.3	3.84 97.5	5212
1312	3.053 77.55	4.429 112.50	3.308 84.02	4.187 106.35	0.100 2.54	0.080 2.03	2.87 72.9	3.05 77.5	4.64 117.9	4.42 112.3	1312
7312	3.053 77.55	4.429 112.50	3.308 84.02	4.187 106.35	0.100 2.54	0.080 2.03	2.87 72.9	3.05 77.5	4.64 117.9	4.42 112.3	7312

* The maximum fillet on the shaft or in the housing that the bearing corner will clear.

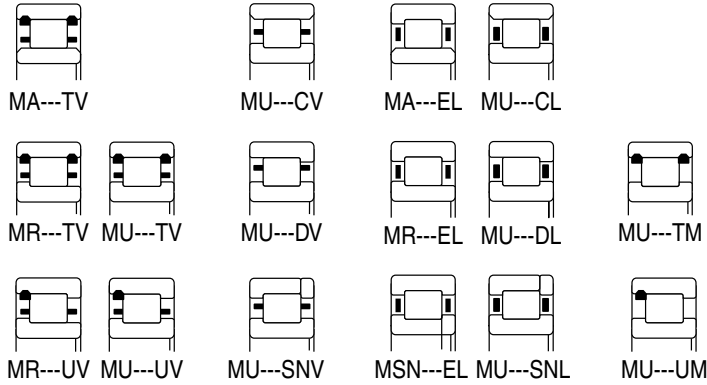
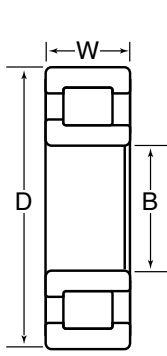

Basic Bearing Number	B		D		W		Radial Load Ratings — lbs./N								
	Bore Diameter	Outside Diameter		Width	One Piece Steel Cage				Composite Steel Cage		X Bar Steel Cage		Full Complement (No Cage)		
		Standard Style	"A" * Style		Outer Ring Assemblies		Inner Ring Assemblies		Dynamic	Static	Dynamic	Static	Dynamic	Static	Dynamic
	Inch/mm				Dynamic	Static	Dynamic	Static	Dynamic	Static	Dynamic	Static	Dynamic	Static	
5312	2.3622 60.000	5.1181 130.000	5.1204 130.058	2.1250 53.975						60000 266000	78000 350000	57000 253000	73000 325000		
1913	2.5591 65.000	3.5433 90.000	3.5449 90.040	0.5118 13.000											
1013	2.5591 65.000	3.9370 100.000	3.9388 100.046	0.7087 18.000			10900 48500	14300 63500	11900 53000	16000 71000					
1213	2.5591 65.000	4.7244 120.000	4.7266 120.056	0.9055 23.000			21800 97000	26300 117000	21800 97000	26300 117000	21800 97000	26300 117000			
5213	2.5591 65.000	4.7244 120.000	4.7266 120.056	1.5000 38.100	33000 147000	45000 20000			34500 153000	47500 211000	34500 153000	47500 211000	40000 177000	57500 265000	
1313	2.5591 65.000	5.5118 140.000	5.5141 140.058	1.2992 33.000	38000 170000	42500 189000	38000 170000	42500 189000	38000 170000	42500 189000	38000 170000	42500 189000	44000 196000	51500 230000	
7313	2.5591 65.000	5.5118 140.000	5.5141 140.058	1.5748 40.000					48500 215000	57500 256000	48500 215000	57500 256000			
5313	2.5591 65.000	5.5118 140.000	5.5141 140.058	2.3125 58.738					67500 300000	88500 395000			78000 345000	107000 475000	
1914	2.7559 70.000	3.9370 100.000	3.9388 100.046	0.6299 16.000											
1014	2.7559 70.000	4.3307 110.000	4.3329 110.056	0.7874 20.000			14300 63500	18000 80000	14300 63500	18000 80000	14800 65500	18800 83500			
1214	2.7559 70.000	4.9213 125.000	4.9236 125.059	0.9449 24.000	23200 103000	27800 124000	23200 103000	27800 124000	23200 103000	27800 124000	24200 107000	29400 131000	28800 128000	37000 165000	
5214	2.7559 70.000	4.9213 125.000	4.9236 125.059	1.5625 39.688	38000 170000	53000 235000			38000 170000	53000 235000					
1314	2.7559 70.000	5.9055 150.000	5.9081 150.066	1.3780 35.000			43000 191000	48500 215000	43000 191000	48500 215000	43000 191000	48500 215000	49500 221000	58500 261000	
7314	2.7559 70.000	5.9055 150.000	5.9081 150.066	1.6929 43.000					54500 242000	65500 291000	54500 242000	65500 291000	63000 280000	79500 355000	
5314	2.7559 70.000	5.9055 150.000	5.9081 150.066	2.5000 63.500											
1915	2.9528 75.000	4.1339 105.000	4.1358 105.049	0.6299 16.000											
1015	2.9528 75.000	4.5276 115.000	4.5298 115.057	0.7874 20.000			14600 65000	18900 84000	14600 65000	18900 84000	15600 69000	20500 91000			
1215	2.9528 75.000	5.1181 130.000	5.1204 130.058	0.9843 25.000	24000 107000	29500 131000			25000 111000	31000 138000			28700 127000	37500 166000	

* Oversize outer ring for heavy press fit in standard housing bore.

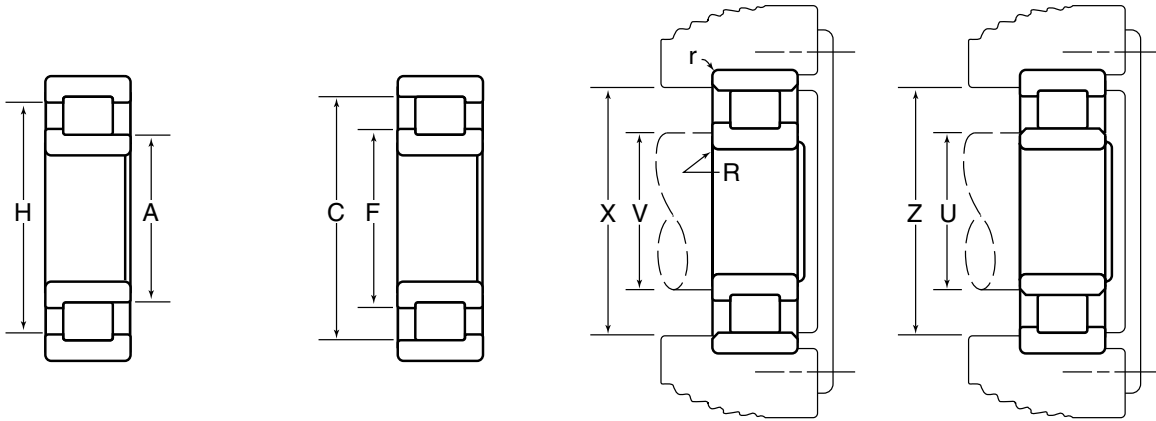

Basic Bearing Number	A	C	F	H	R	r	U	V	X	Z	Basic Bearing Number
	Inner Ring O.D.	Outer Ring I.D.	Inner Ring Rib O.D.	Outer Ring Rib I.D.	Maximum * Fillet Radius		Minimum Shaft Shoulder Diameter		Maximum Housing Shoulder Diameter		
					Shaft	Housing	Plain Rings	Rib Rings	Plain Rings	Rib Rings	
	Inch/mm										
5312	3.053 77.55	4.429 112.50	3.308 84.02	4.187 106.35	0.100 2.54	0.080 2.03	2.87 72.9	3.05 77.5	4.64 117.9	4.42 112.3	5312
1913	2.875 71.76	3.284 83.41	2.925 74.30	3.184 80.87	0.040 1.02	0.040 1.02	2.76 70.1	2.82 71.6	3.36 85.3	3.28 83.3	1913
1013	2.933 74.50	3.565 90.55	3.060 77.72	3.439 87.35	0.060 1.52	0.040 1.02	2.84 72.1	2.93 74.4	3.69 93.7	3.56 90.4	1013
1213	3.166 80.42	4.166 105.82	3.360 85.34	3.986 101.24	0.100 2.54	0.060 1.52	3.03 77.0	3.16 80.3	4.33 110.0	4.16 105.7	1213
5213	3.166 80.42	4.166 105.82	3.360 85.34	3.986 101.24	0.100 2.54	0.060 1.52	3.03 77.0	3.16 80.3	4.33 110.0	4.16 105.7	5213
1313	3.294 83.67	4.778 121.36	3.571 90.70	4.515 114.68	0.100 2.54	0.080 2.03	3.10 78.7	3.29 83.6	5.00 127.0	4.77 121.2	1313
7313	3.294 83.67	4.778 121.36	3.571 90.70	4.515 114.68	0.100 2.54	0.080 2.03	3.10 78.7	3.29 83.6	5.00 127.0	4.77 121.2	7313
5313	3.294 83.67	4.778 121.36	3.571 90.70	4.515 114.68	0.100 2.54	0.080 2.03	3.10 78.7	3.29 83.6	5.00 127.0	4.77 121.2	5313
1914	3.070 77.98	3.633 92.28	3.182 80.82	3.520 89.41	0.040 1.02	0.040 1.02	2.99 75.9	3.07 78.0	3.72 94.5	3.63 92.2	1914
1014	3.157 80.19	3.933 99.90	3.312 84.12	3.779 95.99	0.080 2.03	0.040 1.02	3.05 77.5	3.15 80.0	4.07 103.4	3.93 99.8	1014
1214	3.338 84.79	4.391 111.53	3.528 89.61	4.213 107.01	0.100 2.54	0.060 1.52	3.22 81.8	3.33 84.6	4.55 115.6	4.39 111.5	1214
5214	3.338 84.79	4.391 111.53	3.528 89.61	4.213 107.01	0.100 2.54	0.060 1.52	3.22 81.8	3.33 84.6	4.55 115.6	4.39 111.5	5214
1314	3.512 89.20	5.094 129.39	3.808 96.72	4.811 122.20	0.125 3.18	0.080 2.03	3.32 84.3	3.51 89.2	5.34 135.6	5.09 129.3	1314
7314	3.512 89.20	5.094 129.39	3.808 96.72	4.811 122.20	0.125 3.18	0.080 2.03	3.32 84.3	3.51 89.2	5.34 135.6	5.09 129.3	7314
5314	3.512 89.20	5.094 129.39	3.808 96.72	4.811 122.20	0.125 3.18	0.080 2.03	3.32 84.3	3.51 89.2	5.34 135.6	5.09 129.3	5314
1915	3.265 82.93	3.828 97.23	3.377 85.78	3.716 94.39	0.040 1.02	0.040 1.02	3.18 80.8	3.26 82.8	3.92 99.6	3.82 97.0	1915
1015	3.355 85.22	4.131 104.93	3.510 89.15	3.977 101.02	0.080 2.03	0.040 1.02	3.25 82.6	3.35 85.1	4.27 108.5	4.13 104.9	1015
1215	3.505 89.03	4.558 115.77	3.695 93.85	4.380 111.25	0.100 2.54	0.060 1.52	3.37 85.6	3.50 88.9	4.73 120.1	4.55 115.6	1215

* The maximum fillet on the shaft or in the housing that the bearing corner will clear.

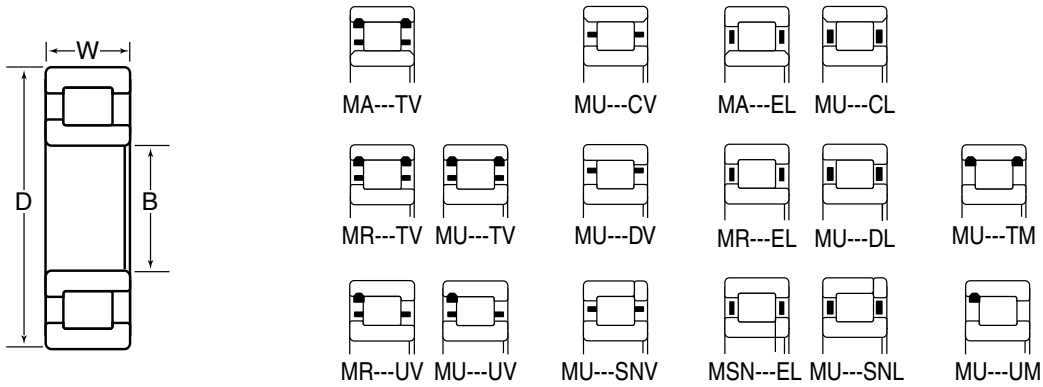

Basic Bearing Number	B		D		W	Radial Load Ratings — lbs./N									
	Bore Diameter	Outside Diameter		Width	One Piece Steel Cage				Composite Steel Cage		X Bar Steel Cage		Full Complement (No Cage)		
		Standard Style	"A" * Style		Outer Ring Assemblies		Inner Ring Assemblies		Dynamic	Static	Dynamic	Static	Dynamic	Static	Dynamic
	Inch/mm					Dynamic	Static	Dynamic	Static	Dynamic	Static	Dynamic	Static	Dynamic	Static
5215	2.9528 75.000	5.1181 130.000	5.1204 130.058	1.6250 41.275						43000 191000	62500 278000	43000 191000	62500 278000		
1315	2.9528 75.000	6.2992 160.000	6.3020 160.071	1.4567 37.000			45500 202000	50500 224000		45500 202000	50500 224000	45500 202000	50500 224000	52500 233000	61000 272000
7315	2.9528 75.000	6.2992 160.000	6.3020 160.071	1.8110 46.000						60000 267000	72500 320000				
5315	2.9528 75.000	6.2992 160.000	6.3020 160.071	2.6875 68.262											
1916	3.1496 80.000	4.3307 110.000	4.3329 110.056	0.6299 16.000											
1016	3.1496 80.000	4.9213 125.000	4.9236 125.059	0.8661 22.000						18500 82500	23900 107000	17600 78500	23500 104000		
1216	3.1496 80.000	5.5118 140.000	5.5141 140.058	1.0236 26.000	25600 114000	30500 136000				26700 119000	32500 144000	27700 123000	34000 151000	31000 137000	39000 174000
5216	3.1496 80.000	5.5118 140.000	5.5141 140.058	1.7500 44.450	44500 199000	62500 278000				46500 207000	66000 294000	48500 215000	69500 310000		
1316	3.1496 80.000	6.6929 170.000	6.6957 170.071	1.5354 39.000						54000 241000	62000 276000			59500 265000	70500 315000
7316	3.1496 80.000	6.6929 170.000	6.6957 170.071	1.9291 49.000											
5316	3.1496 80.000	6.6929 170.000	6.6957 170.071	2.6875 68.262						95000 420000	127000 565000				
1917	3.3465 85.000	4.7244 120.000	4.7266 120.056	0.7087 18.000											
1017	3.3465 85.000	5.1181 130.000	5.1204 130.058	0.8661 22.000			17800 79500	23000 103000		19000 84500	25100 112000	19600 87500	26200 117000		
1217	3.3465 85.000	5.9055 150.000	5.9081 150.066	1.1024 28.000	31000 139000	38000 169000				31000 139000	38000 169000	32500 145000	40000 178000	37500 167000	48500 216000
5217	3.3465 85.000	5.9055 150.000	5.9081 150.066	1.9375 49.212						55500 246000	79000 350000	57500 256000	83500 370000		
1317	3.3465 85.000	7.0866 180.000	7.0894 180.071	1.6142 41.000						54500 243000	61000 272000				
7317	3.3465 85.000	7.0866 180.000	7.0894 180.071	2.0079 51.000						75500 355000	92500 410000	75500 335000	92500 410000		
5317	3.3465 85.000	7.0866 180.000	7.0894 180.071	2.8750 73.025										122000 540000	172000 765000

* Oversize outer ring for heavy press fit in standard housing bore.

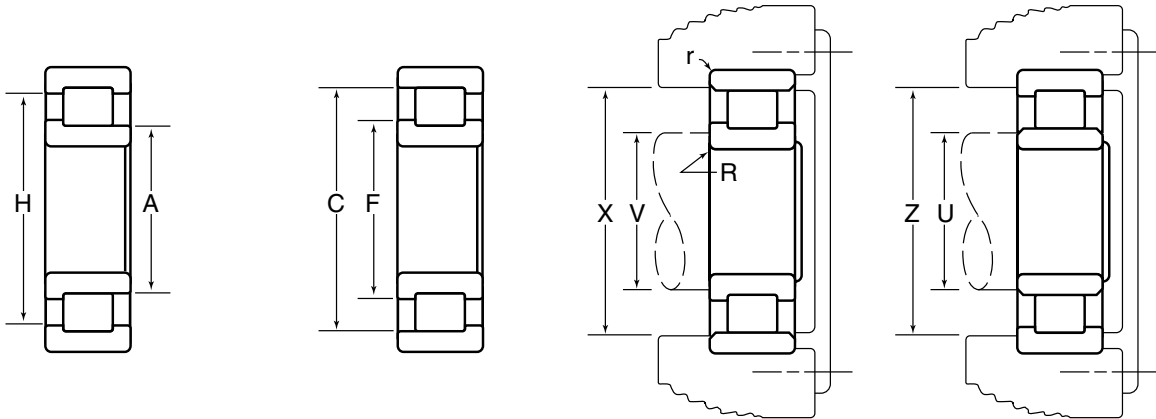

Basic Bearing Number	A	C	F	H	R	r	U	V	X	Z	Basic Bearing Number
	Inner Ring O.D.	Outer Ring I.D.	Inner Ring Rib O.D.	Outer Ring Rib I.D.	Maximum * Fillet Radius		Minimum Shaft Shoulder Diameter		Maximum Housing Shoulder Diameter		
					Shaft	Housing	Plain Rings	Rib Rings	Plain Rings	Rib Rings	
	Inch/mm										
5215	3.505 89.03	4.558 115.77	3.695 93.85	4.380 111.25	0.100 2.54	0.060 1.52	3.37 85.6	3.50 88.9	4.73 120.1	4.55 115.6	5215
1315	3.776 95.91	5.478 139.14	4.096 104.04	5.172 131.37	0.125 3.18	0.080 2.03	3.56 90.4	3.77 95.8	5.74 145.8	5.47 138.9	1315
7315	3.776 95.91	5.478 139.14	4.096 104.04	5.172 131.37	0.125 3.18	0.080 2.03	3.56 90.4	3.77 95.8	5.74 145.8	5.47 138.9	7315
5315	3.776 95.91	5.478 139.14	4.096 104.04	5.172 131.37	0.125 3.18	0.080 2.03	3.56 90.4	3.77 95.8	5.74 145.8	5.47 138.9	5315
1916	3.460 87.88	4.023 102.18	3.572 90.73	3.911 99.34	0.040 1.02	0.040 1.02	3.38 85.9	3.46 87.9	4.11 104.4	4.02 102.1	1916
1016	3.595 91.31	4.454 113.13	3.771 95.78	4.303 109.30	0.080 2.03	0.040 1.02	3.48 88.4	3.59 91.2	4.63 117.6	4.47 113.5	1016
1216	3.751 95.28	4.908 124.66	3.968 100.79	4.700 119.38	0.100 2.54	0.080 2.03	3.59 91.2	3.75 95.2	5.09 129.3	4.90 124.5	1216
5216	3.751 95.28	4.908 124.66	3.968 100.79	4.700 119.38	0.100 2.54	0.080 2.03	3.59 91.2	3.75 95.2	5.09 129.3	4.90 124.5	5216
1316	4.001 101.63	5.804 147.42	4.342 110.29	5.480 139.19	0.125 3.18	0.080 2.03	3.78 96.0	4.00 101.6	6.08 154.4	5.80 147.3	1316
7316	4.001 101.63	5.804 147.42	4.342 110.29	5.480 139.19	0.125 3.18	0.080 2.03	3.78 96.0	4.00 101.6	6.08 154.4	5.80 147.3	7316
5316	4.001 101.63	5.804 147.42	4.342 110.29	5.480 139.19	0.125 3.18	0.080 2.03	3.78 96.0	4.00 101.6	6.08 154.4	5.80 147.3	5316
1917	3.725 94.62	4.357 110.67	3.851 97.82	4.231 107.47	0.060 1.52	0.040 1.02	3.63 92.2	3.72 94.5	4.48 113.8	4.35 110.5	1917
1017	3.792 96.32	4.654 118.21	3.968 100.79	4.500 114.30	0.080 2.03	0.040 1.02	3.68 93.5	3.79 96.3	4.83 122.7	4.67 118.6	1017
1217	4.016 102.01	5.284 134.21	4.254 108.05	5.056 128.42	0.125 3.18	0.080 2.03	3.86 98.0	4.01 101.9	5.48 139.2	5.28 134.1	1217
5217	4.016 102.01	5.284 134.21	4.254 108.05	5.056 128.42	0.125 3.18	0.080 2.03	3.86 98.0	4.01 101.9	5.48 139.2	5.28 134.1	5217
1317	4.273 108.53	6.198 157.43	4.655 118.24	5.852 148.64	0.156 3.96	0.100 2.54	4.05 102.9	4.27 108.5	6.47 164.3	6.19 157.2	1317
7317	4.273 108.53	6.198 157.43	4.655 118.24	5.852 148.64	0.156 3.96	0.100 2.54	4.05 102.9	4.27 108.5	6.47 164.3	6.19 157.2	7317
5317	4.273 108.53	6.198 157.43	4.655 118.24	5.852 148.64	0.156 3.96	0.100 2.54	4.05 102.9	4.27 108.5	6.47 164.3	6.19 157.2	5317

* The maximum fillet on the shaft or in the housing that the bearing corner will clear.

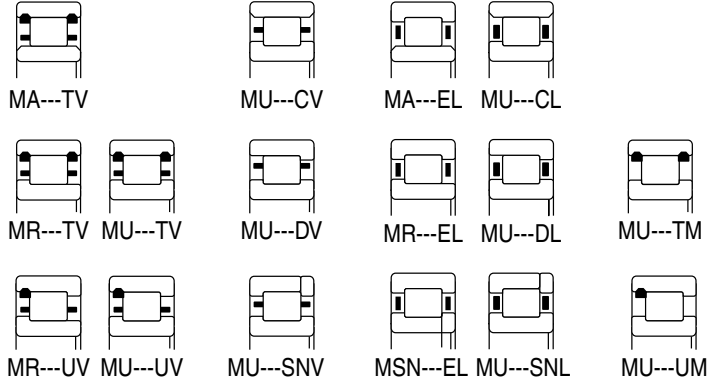
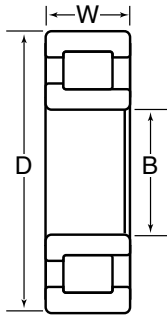

Basic Bearing Number	B		D		W		Radial Load Ratings — lbs./N									
	Bore Diameter	Outside Diameter		Width	One Piece Steel Cage				Composite Steel Cage		X Bar Steel Cage		Full Complement (No Cage)			
		Standard Style	"A" * Style		Outer Ring Assemblies		Inner Ring Assemblies		Dynamic	Static	Dynamic	Static	Dynamic	Static	Dynamic	Static
	Inch/mm				Dynamic	Static	Dynamic	Static								
1918	3.5433 90.000	4.9213 125.000	4.9236 125.059	0.7087 18.000												
1018	3.5433 90.000	5.5118 140.000	5.5141 140.058	0.9449 24.000												
1218	3.5433 90.000	6.2992 160.000	6.3020 160.071	1.1811 30.000			36500 163000	45000 200000	35000 156000	42500 189000	38000 170000	47500 211000	43000 192000	55000 246000		
5218	3.5433 90.000	6.2992 160.000	6.3020 160.071	2.0625 52.388	65000 290000	94000 420000						68000 300000	99000 440000			
1318	3.5433 90.000	7.4803 190.000	7.4833 190.076	1.6929 43.000			68500 305000	80000 355000	61500 273000	69500 310000	68500 305000	80000 355000				
7318	3.5433 90.000	7.4803 190.000	7.4833 190.076	2.1260 54.000												
5318	3.5433 90.000	7.4803 190.000	7.4833 190.076	2.8750 73.025							114000 510000	155000 690000				
1919	3.7402 95.000	5.1181 130.000	5.1204 130.058	0.7087 18.000												
1019	3.7402 95.000	5.7087 145.000	5.7113 145.067	0.9449 24.000												
1219	3.7402 95.000	6.6929 170.000	6.6957 170.071	1.2598 32.000							43000 192000	53500 238000				
5219	3.7402 95.000	6.6929 170.000	6.6957 170.071	2.1875 55.562					72000 320000	103000 460000						
1319	3.7402 95.000	7.8740 200.000	7.8771 200.078	1.7717 45.000					65000 289000	75500 335000	68500 305000	81000 360000				
7319	3.7402 95.000	7.8740 200.000	7.8771 200.078	2.2047 56.000							93500 415000	121000 540000				
5319	3.7402 95.000	7.8740 200.000	7.8771 200.078	3.0625 77.788							120000 535000	168000 745000				
1920	3.9370 100.000	5.5118 140.000	5.5141 140.058	0.7874 20.000												
1020	3.9370 100.000	5.9055 150.000	5.9081 150.066	0.9499 24.000			20300 90000	28700 128000								
1220	3.9370 100.000	7.0866 180.000	7.0894 180.071	1.3386 34.000					47500 211000	59000 263000						
5220	3.9370 100.000	7.0866 180.000	7.0894 180.071	2.3750 60.325	83000 370000	121000 540000					83000 370000	121000 540000				

* Oversize outer ring for heavy press fit in standard housing bore.

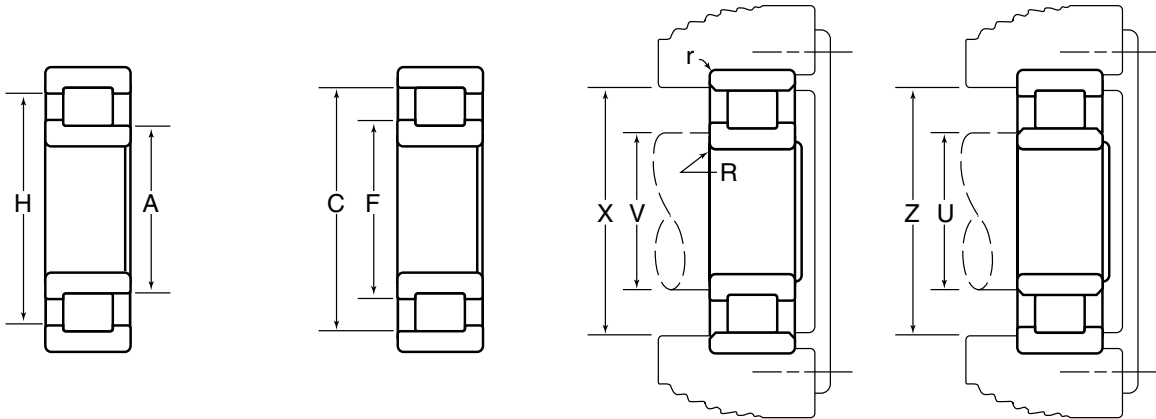

Basic Bearing Number	A	C	F	H	R	r	U	V	X	Z	Basic Bearing Number
	Inner Ring O.D.	Outer Ring I.D.	Inner Ring Rib O.D.	Outer Ring Rib I.D.	Maximum * Fillet Radius		Minimum Shaft Shoulder Diameter		Maximum Housing Shoulder Diameter		
					Shaft	Housing	Plain Rings	Rib Rings	Plain Rings	Rib Rings	
	Inch/mm										
1918	3.920 99.57	4.553 115.65	4.046 102.77	4.426 112.42	0.060 1.52	0.040 1.02	3.82 97.0	3.92 99.6	4.67 118.6	4.55 115.6	1918
1018	4.030 102.36	5.031 127.79	4.229 107.42	4.831 122.71	0.100 2.54	0.060 1.52	3.92 99.6	4.03 102.4	5.18 131.6	5.03 127.8	1018
1218	4.221 107.21	5.598 142.19	4.495 114.17	5.350 135.89	0.125 3.18	0.080 2.03	4.06 103.1	4.22 107.2	5.81 147.6	5.59 142.0	1218
5218	4.221 107.21	5.598 142.19	4.495 114.17	5.350 135.89	0.125 3.18	0.080 2.03	4.06 103.1	4.22 107.2	5.81 147.6	5.59 142.0	5218
1318	4.489 114.02	6.512 165.40	4.895 124.33	6.148 156.16	0.156 3.96	0.100 2.54	4.26 108.2	4.48 113.8	6.80 172.7	6.51 165.4	1318
7318	4.489 114.02	6.512 165.40	4.895 124.33	6.148 156.16	0.156 3.96	0.100 2.54	4.26 108.2	4.48 113.8	6.80 172.7	6.51 165.4	7318
5318	4.489 114.02	6.512 165.40	4.895 124.33	6.148 156.16	0.156 3.96	0.100 2.54	4.26 108.2	4.48 113.8	6.80 172.7	6.51 165.4	5318
1919	4.115 104.52	4.748 120.60	4.241 107.72	4.622 117.40	0.060 1.52	0.040 1.02	4.02 102.1	4.11 104.4	4.87 123.7	4.74 120.4	1919
1019	4.226 107.34	5.227 132.77	4.425 112.40	5.027 127.69	0.100 2.54	0.060 1.52	4.11 104.4	4.22 107.2	5.38 136.7	5.22 132.6	1019
1219	4.469 113.51	5.954 151.23	4.765 121.03	5.688 144.48	0.125 3.18	0.080 2.03	4.29 109.0	4.46 113.3	6.18 157.0	5.95 151.1	1219
5219	4.469 113.51	5.954 151.23	4.765 121.03	5.688 144.48	0.125 3.18	0.080 2.03	4.29 109.0	4.46 113.3	6.18 157.0	5.95 151.1	5219
1319	4.809 122.15	6.832 173.53	5.215 132.46	6.468 164.29	0.156 3.96	0.100 2.54	4.53 155.1	4.80 121.9	7.16 181.9	6.83 173.5	1319
7319	4.809 122.15	6.832 173.53	5.215 132.46	6.468 164.29	0.156 3.96	0.100 2.54	4.53 155.1	4.80 121.9	7.16 181.9	6.83 173.5	7319
5319	4.809 122.15	6.832 173.53	5.215 132.46	6.468 164.29	0.156 3.96	0.100 2.54	4.53 155.1	4.80 121.9	7.16 181.9	6.83 173.5	5319
1920	4.331 110.01	5.108 129.74	4.485 113.92	4.953 125.81	0.060 1.52	0.040 1.02	4.22 107.2	4.33 110.0	5.25 133.4	5.10 129.5	1920
1020	4.423 112.34	5.424 137.77	4.622 117.40	5.224 132.69	0.100 2.54	0.060 1.52	4.31 109.5	4.42 112.3	5.58 141.7	5.42 137.7	1020
1220	4.764 121.01	6.347 161.21	5.057 128.45	6.070 154.18	0.156 3.96	0.080 2.03	4.57 116.1	4.76 120.9	6.58 167.1	6.34 161.0	1220
5220	4.764 121.01	6.347 161.21	5.057 128.45	6.070 154.18	0.156 3.96	0.080 2.03	4.57 116.1	4.76 120.9	6.58 167.1	6.34 161.0	5220

* The maximum fillet on the shaft or in the housing that the bearing corner will clear.

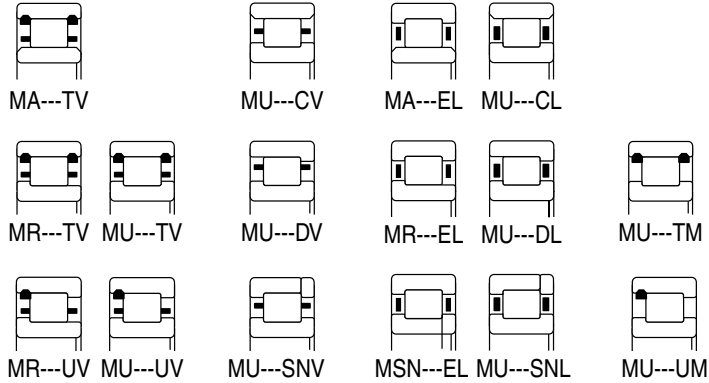
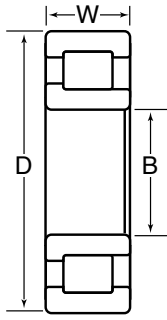

Basic Bearing Number	B		D		W		Radial Load Ratings — lbs./N							
	Bore Diameter	Outside Diameter		Width	One Piece Steel Cage				Composite Steel Cage		X Bar Steel Cage		Full Complement (No Cage)	
		Standard Style	"A" * Style		Outer Ring Assemblies		Inner Ring Assemblies		Dynamic	Static	Dynamic	Static	Dynamic	Static
	Inch/mm				Dynamic	Static	Dynamic	Static	Dynamic	Static	Dynamic	Static	Dynamic	Static
1320	3.9370 100.000	8.4646 215.000	8.4680 215.087	1.8504 47.000					71500 320000	84000 375000			86500 385000	108000 480000
7320	3.9370 100.000	8.4646 215.000	8.4680 215.087	2.3622 60.000					98000 435000	125000 555000				
5320	3.9370 100.000	8.4646 215.000	8.4680 215.087	3.2500 82.550							143000 640000	206000 915000		
1921	4.1339 105.000	5.7087 145.000	5.7113 145.067	0.7874 20.000			17400 77000	25900 115000			18200 81000	27500 122000	20200 89500	31500 140000
1021	4.1339 105.000	6.2992 160.000	6.3020 160.071	1.0236 26.000			30500 135000	43500 193000	30500 135000	43500 193000	31000 139000	45000 201000		
1221	4.1339 105.000	7.4803 190.000	7.4833 190.076	1.4173 36.000	48500 216000	59500 265000	50500 225000	63000 280000					59000 262000	77000 340000
5221	4.1339 105.000	7.4803 190.000	7.4833 190.076	2.5625 65.088	90500 405000	133000 590000								
1321	4.1339 105.000	8.8583 225.000	8.8618 225.090	1.9291 49.000			89500 400000	110000 490000	85000 380000	103000 455000			103000 455000	132000 585000
7321	4.1339 105.000	8.8583 225.000	8.8618 225.090	2.4803 63.000										
5321	4.1339 105.000	8.8583 225.000	8.8618 225.090	3.4375 87.312										
1922	4.3307 110.000	5.9055 150.000	5.9081 150.066	0.7874 20.000			17600 78500	26800 119000	17600 78500	26800 119000	17600 78500	26800 119000		
1022	4.3307 110.000	6.6929 170.000	6.6957 170.071	1.1024 28.000					34500 154000	49000 218000				
1222	4.3307 110.000	7.8740 200.000	7.8771 200.078	1.4961 38.000	54000 240000	68000 305000	54000 240000	68000 305000	52000 230000	64500 287000	56500 250000	72000 320000	63000 280000	83000 370000
7222	4.3307 110.000	7.8740 200.000	7.8771 200.078	1.8110 46.000					68500 305000	92500 410000				
5222	4.3307 110.000	7.8740 200.000	7.8771 200.078	2.7500 69.850					94000 420000	139000 620000	102000 455000	155000 690000		
1322	4.3307 110.000	9.4488 240.000	9.4526 240.096	1.9685 50.000										
7322	4.3307 110.000	9.4488 240.000	9.4526 240.096	2.5591 65.000										
5322	4.3307 110.000	9.4488 240.000	9.4526 240.096	3.6250 92.075										
1924	4.7244 120.000	6.4961 165.000	6.4989 165.072	0.8661 22.000			22000 98000	33500 148000						

* Oversize outer ring for heavy press fit in standard housing bore.

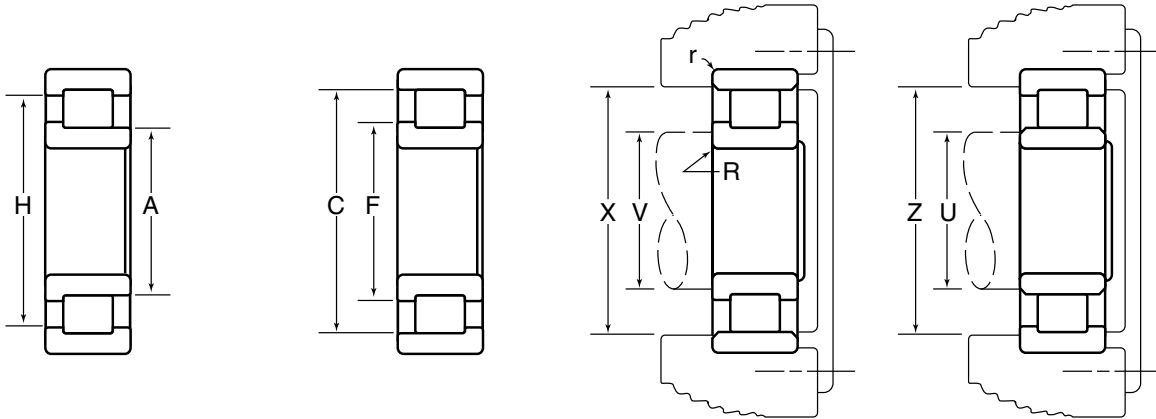

Basic Bearing Number	A	C	F	H	R	r	U	V	X	Z	Basic Bearing Number
	Inner Ring O.D.	Outer Ring I.D.	Inner Ring Rib O.D.	Outer Ring Rib I.D.	Maximum * Fillet Radius		Minimum Shaft Shoulder Diameter		Maximum Housing Shoulder Diameter		
					Shaft	Housing	Plain Rings	Rib Rings	Plain Rings	Rib Rings	
	Inch/mm										
1320	5.125	7.280	5.530	6.892	0.187	0.100	4.82	5.12	7.66	7.28	1320
	130.18	184.91	140.46	175.06	4.75	2.54	122.4	130.0	194.6	184.9	
7320	5.125	7.280	5.530	6.892	0.187	0.100	4.82	5.12	7.66	7.28	7320
	130.18	184.91	140.46	175.06	4.75	2.54	122.4	130.0	194.6	184.9	
5320	5.125	7.280	5.530	6.892	0.187	0.100	4.82	5.12	7.66	7.28	5320
	130.18	184.91	140.46	175.06	4.75	2.54	122.4	130.0	194.6	184.9	
1921	4.527	5.305	4.682	5.150	0.060	0.040	4.41	4.52	5.44	5.30	1921
	114.99	134.75	118.92	130.81	1.52	1.02	112.0	114.8	138.2	134.6	
1021	4.691	5.746	4.901	5.536	0.100	0.080	4.56	4.69	5.91	5.74	1021
	119.15	145.95	124.49	140.61	2.54	2.03	115.8	119.1	150.1	145.8	
1221	4.981	6.636	5.310	6.339	0.156	0.080	4.78	4.98	6.90	6.63	1221
	126.52	168.55	134.87	161.01	3.96	2.03	121.4	126.5	175.3	168.4	
5221	4.981	6.636	5.310	6.339	0.156	0.080	4.78	4.98	6.90	6.63	5221
	126.52	168.55	134.87	161.01	3.96	2.03	121.4	126.5	175.3	168.4	
1321	5.362	7.616	5.794	7.211	0.187	0.100	5.04	5.36	8.01	7.61	1321
	136.19	193.45	147.17	183.16	4.75	2.54	128.0	136.1	203.5	193.3	
7321	5.362	7.616	5.794	7.211	0.187	0.100	5.04	5.36	8.01	7.61	7321
	136.19	193.45	147.17	183.16	4.75	2.54	128.0	136.1	203.5	193.3	
5321	5.362	7.616	5.794	7.211	0.187	0.100	5.04	5.36	8.01	7.61	5321
	136.19	193.45	147.17	183.16	4.75	2.54	128.0	136.1	203.5	193.3	
1922	4.724	5.502	4.879	5.347	0.060	0.040	4.61	4.72	5.64	5.50	1922
	119.99	139.75	123.93	135.81	1.52	1.02	117.1	119.9	143.3	139.7	
1022	4.935	6.092	5.166	5.862	0.100	0.080	4.80	4.93	6.27	6.09	1022
	125.35	154.74	131.22	148.89	2.54	2.03	121.9	125.2	159.3	154.7	
1222	5.234	6.937	5.575	6.631	0.156	0.080	5.01	5.23	7.24	6.93	1222
	132.94	176.20	141.60	168.43	3.96	2.03	127.3	132.8	183.9	176.0	
7222	5.234	6.937	5.575	6.631	0.156	0.080	5.01	5.23	7.24	6.93	7222
	132.94	176.20	141.60	168.43	3.96	2.03	127.3	132.8	183.9	176.0	
5222	5.234	6.937	5.575	6.631	0.156	0.080	5.01	5.23	7.24	6.93	5222
	132.94	176.20	141.60	168.43	3.96	2.03	127.3	132.8	183.9	176.0	
1322	5.719	8.124	6.200	7.692	0.187	0.100	5.35	5.71	8.55	8.12	1322
	145.26	206.35	157.48	195.38	4.75	2.54	135.9	145.0	217.2	206.2	
7322	5.719	8.124	6.200	7.692	0.187	0.100	5.35	5.71	8.55	8.12	7322
	145.26	206.35	157.48	195.38	4.75	2.54	135.9	145.0	217.2	206.2	
5322	5.719	8.124	6.200	7.692	0.187	0.100	5.35	5.71	8.55	8.12	5322
	145.26	206.35	157.48	195.38	4.75	2.54	135.9	145.0	217.2	206.2	
1924	5.177	6.062	5.353	5.886	0.080	0.040	5.11	5.17	6.21	6.06	1924
	131.50	153.97	135.97	149.50	2.03	1.02	129.8	131.3	157.7	153.9	

* The maximum fillet on the shaft or in the housing that the bearing corner will clear.

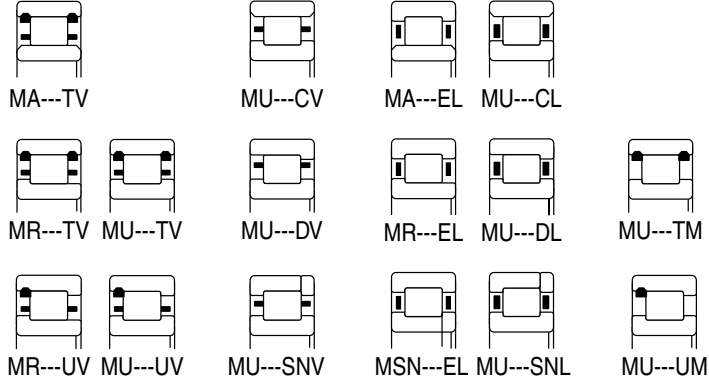
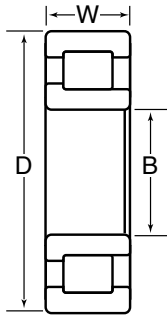

Basic Bearing Number	B		D		W	Radial Load Ratings — lbs./N								
	Bore Diameter	Outside Diameter		Width	One Piece Steel Cage				Composite Steel Cage		X Bar Steel Cage		Full Complement (No Cage)	
		Standard Style	"A" * Style		Outer Ring Assemblies		Inner Ring Assemblies		Dynamic	Static	Dynamic	Static	Dynamic	Static
	Inch/mm					Dynamic	Static	Dynamic	Static	Dynamic	Static	Dynamic	Static	Dynamic
1024	4.7244 120.000	7.0866 180.000	7.0894 180.071	1.1024 28.000			36500 162000	53500 238000			37500 167000	55500 247000		
1224	4.7244 120.000	8.4646 215.000	8.4680 215.087	1.5748 40.000					61000 272000	79000 350000	64000 284000	83500 370000		
5224	4.7244 120.000	8.4646 215.000	8.4680 215.087	3.0000 76.200					128000 570000	204000 905000	133000 595000	215000 955000		
1324	4.7244 120.000	10.2362 260.000	10.2402 260.101	2.1654 55.000										
7324	4.7244 120.000	10.2362 260.000	10.2402 260.101	2.7953 71.000										
5324	4.7244 120.000	10.2362 260.000	10.2402 260.101	4.1250 4.775							214000 950000	305000 1370000		
1926	5.1181 130.000	7.0866 180.000	7.0894 180.071	0.9449 24.000			29400 131000	45500 203000	30000 134000	47000 209000	30000 134000	47000 209000		
1026	5.1181 130.000	7.8740 200.000	7.8771 200.078	1.2992 33.000			46500 207000	66500 296000	46500 207000	66500 296000				
1226	5.1181 130.000	9.0551 230.000	9.0587 230.091	1.5748 40.000					62500 277000	78500 350000	70500 315000	92500 410000		
5226	5.1181 130.000	9.0551 230.000	9.0587 230.091	3.1250 79.375					116000 515000	174000 775000	126000 560000	195000 865000		
1326	5.1181 130.000	11.0236 280.000	11.0276 280.101	2.2835 58.000							124000 555000	154000 685000		
7326	5.1181 130.000	11.0236 280.000	11.0276 280.101	2.9528 75.000										
5326	5.1181 130.000	11.0236 280.000	11.0276 280.101	4.3750 111.125										
1928	5.5118 140.000	7.4803 190.000	7.4833 190.076	0.9449 24.000					31000 138000	50000 222000				
1028	5.5118 140.000	8.2677 210.000	8.2709 210.081	1.2992 33.000										
1228	5.5118 140.000	9.8425 250.000	9.8463 250.096	1.6535 42.000	78000 345000	98500 435000	78000 345000	98500 435000			78000 345000	98500 435000	90500 405000	120000 535000
5228	5.5118 140.000	9.8425 250.000	9.8463 250.096	3.2500 82.550							159000 710000	247000 1100000		
1328	5.5118 140.000	11.8110 300.000	11.8154 300.111	2.4409 62.000										

* Oversize outer ring for heavy press fit in standard housing bore.

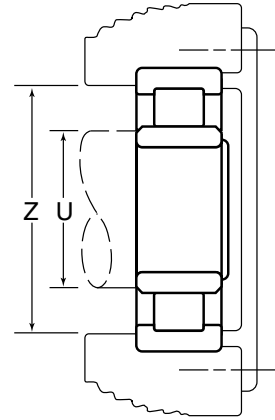
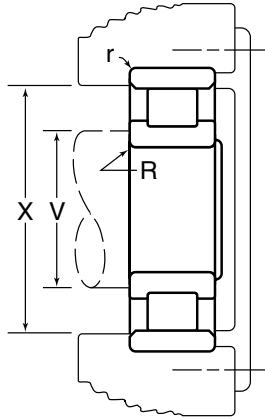
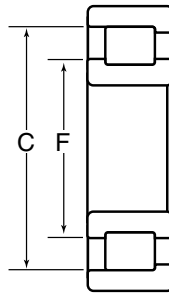
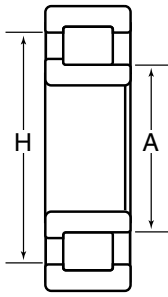

Basic Bearing Number	A	C	F	H	R	r	U	V	X	Z	Basic Bearing Number
	Inner Ring O.D.	Outer Ring I.D.	Inner Ring Rib O.D.	Outer Ring Rib I.D.	Maximum * Fillet Radius		Minimum Shaft Shoulder Diameter		Maximum Housing Shoulder Diameter		
					Shaft	Housing	Plain Rings	Rib Rings	Plain Rings	Rib Rings	
Inch/mm											
1024	5.329	6.486	5.560	6.256	0.125	0.080	5.20	5.32	6.66	6.48	1024
	135.36	164.74	141.22	158.90	3.18	2.03	132.1	135.1	169.2	164.6	
1224	5.714	7.518	6.075	7.194	0.187	0.080	5.48	5.71	7.83	7.51	1224
	145.14	190.96	154.30	182.73	4.75	2.03	139.2	145.0	198.9	190.8	
5224	5.714	7.518	6.075	7.194	0.187	0.080	5.48	5.71	7.83	7.51	5224
	145.14	190.96	154.30	182.73	4.75	2.03	139.2	145.0	198.9	190.8	
1324	6.182	8.782	6.700	8.315	0.250	0.100	5.82	6.18	9.26	8.78	1324
	157.02	223.06	170.18	211.20	6.35	2.54	147.8	157.0	235.2	223.0	
7324	6.182	8.782	6.700	8.315	0.250	0.100	5.82	6.18	9.26	8.78	7324
	157.02	223.06	170.18	211.20	6.35	2.54	147.8	157.0	235.2	223.0	
5324	6.182	8.782	6.700	8.315	0.250	0.100	5.82	6.18	9.26	8.78	5324
	157.02	223.06	170.18	211.20	6.35	2.54	147.8	157.0	235.2	223.0	
1926	5.605	6.607	5.804	6.407	0.080	0.060	5.48	5.60	6.76	6.60	1926
	142.37	167.82	147.42	162.74	2.03	1.52	139.2	142.2	171.7	167.6	
1026	5.810	7.188	6.085	6.913	0.125	0.080	5.63	5.81	7.41	7.18	1026
	147.57	182.58	154.56	175.59	3.18	2.03	143.0	147.6	188.2	182.4	
1226	6.101	8.125	6.485	7.761	0.187	0.100	5.87	6.10	8.42	8.12	1226
	154.97	206.38	164.72	197.13	4.75	2.54	149.1	154.9	213.9	206.2	
5226	6.101	8.125	6.485	7.761	0.187	0.100	5.87	6.10	8.42	8.12	5226
	154.97	206.38	164.72	197.13	4.75	2.54	149.1	154.9	213.9	206.2	
1326	6.714	9.557	7.280	9.046	0.250	0.125	6.31	6.71	10.02	9.55	1326
	170.54	242.75	184.91	229.77	6.35	3.18	160.3	170.4	254.5	242.6	
7326	6.714	9.557	7.280	9.046	0.250	0.125	6.31	6.71	10.02	9.55	7326
	170.54	242.75	184.91	229.77	6.35	3.18	160.3	170.4	254.5	242.6	
5326	6.714	9.557	7.280	9.046	0.250	0.125	6.31	6.71	10.02	9.55	5326
	170.54	242.75	184.91	229.77	6.35	3.18	160.3	170.4	254.5	242.6	
1928	6.001	7.003	6.200	6.803	0.080	0.060	5.87	6.00	7.15	7.00	1928
	152.43	177.88	157.48	172.80	2.03	1.52	149.1	152.4	181.6	177.8	
1028	6.203	7.581	6.478	7.307	0.156	0.080	6.05	6.20	7.80	7.58	1028
	157.56	192.56	164.54	185.60	3.96	2.03	153.7	157.5	198.1	192.5	
1228	6.632	8.835	7.050	8.440	0.187	0.100	6.36	6.63	9.15	8.83	1228
	168.45	224.41	179.07	214.38	4.75	2.54	161.5	168.4	232.4	224.3	
5228	6.632	8.835	7.050	8.440	0.187	0.100	6.36	6.63	9.15	8.83	5228
	168.45	224.41	179.07	214.38	4.75	2.54	161.5	168.4	232.4	224.3	
1328	7.153	10.161	7.755	9.620	0.312	0.125	6.77	7.15	10.68	10.16	1328
	181.69	258.09	196.98	244.35	7.92	3.18	172.0	181.6	271.3	258.1	

* The maximum fillet on the shaft or in the housing that the bearing corner will clear.

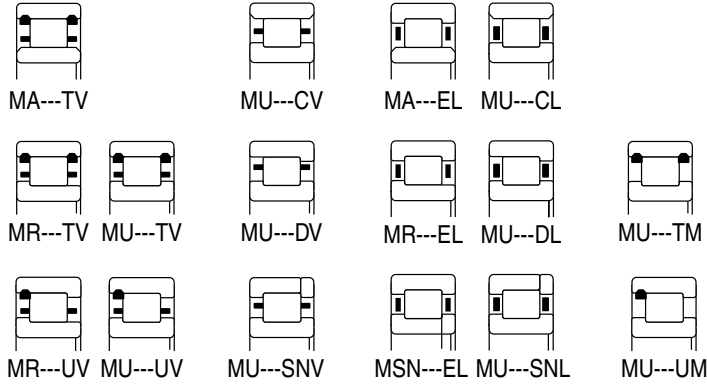
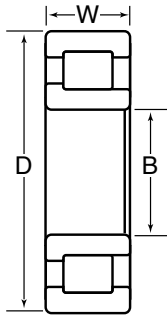

Basic Bearing Number	B	D		W	Radial Load Ratings — lbs./N									
		Bore Diameter	Outside Diameter		One Piece Steel Cage				Composite Steel Cage		X Bar Steel Cage		Full Complement (No Cage)	
	Inch/mm		Standard Style	"A" * Style	Width	Outer Ring Assemblies		Inner Ring Assemblies		Dynamic	Static	Dynamic	Static	Dynamic
		Dynamic				Static	Dynamic	Static						
7328	5.5118 140.000	11.8110 300.000	11.8154 300.111	3.2677 83.000										
5328	5.5118 140.000	11.8110 300.000	11.8154 300.111	4.5000 114.300										
1930	5.9055 150.000	8.2677 210.000	8.2709 210.081	1.1024 28.000					44000 196000	66500 297000	44000 196000	66500 297000		
1030	5.9055 150.000	8.8583 225.000	8.8618 225.090	1.3780 35.000					57500 256000	87000 385000				
5030	5.9055 150.000	8.8583 225.000	8.8618 225.090	2.2047 56.000							95000 420000	165000 735000		
5230	5.9055 150.000	10.6299 270.000	10.6339 270.101	3.5000 88.900							185000 825000	292000 1300000		
1330	5.9055 150.000	12.5984 320.000	12.6032 320.121	2.5591 65.000										
7330	5.9055 150.000	12.5984 320.000	12.6032 320.121	3.4252 87.000										
5330	5.9055 150.000	12.5984 320.000	12.6032 320.121	4.8750 123.825										
1932	6.2992 160.000	8.6614 220.000	8.6649 220.088	1.1024 28.000										
1032	6.2992 160.000	9.4488 240.000	9.4526 240.096	1.4961 38.000										
1232	6.2992 160.000	11.4173 290.000	11.4216 290.109	1.8898 48.000							111000 495000	145000 645000		
5232	6.2992 160.000	11.4173 290.000	11.4216 290.109	3.8750 98.425							226000 1010000	360000 1610000		
1332	6.2992 160.000	13.3858 340.000	13.3906 340.121	2.6772 68.000										
7332	6.2992 160.000	13.3858 340.000	13.3906 340.121	3.5433 90.000										
5332	6.2992 160.000	13.3858 340.000	13.3906 340.121	5.2500 133.350										
1934	6.6929 170.000	9.0551 230.000	9.0587 230.091	1.1024 28.000			43000 191000	73000 325000			45000 199000	77500 345000		
1034	6.6929 170.000	10.2362 260.000	10.2402 260.101	1.6535 42.000										

* Oversize outer ring for heavy press fit in standard housing bore.

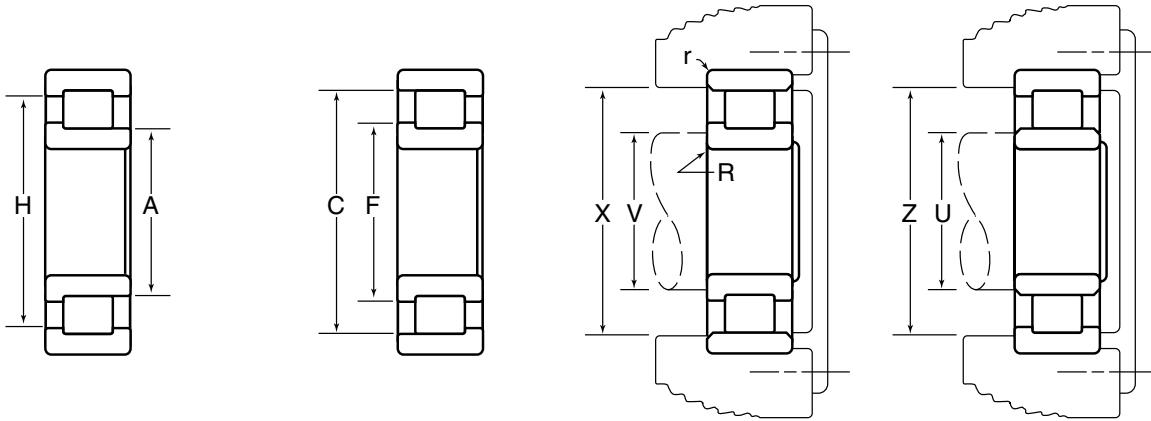

Basic Bearing Number	A	C	F	H	R	r	U	V	X	Z	Basic Bearing Number
	Inner Ring O.D.	Outer Ring I.D.	Inner Ring Rib O.D.	Outer Ring Rib I.D.	Maximum * Fillet Radius		Minimum Shaft Shoulder Diameter		Maximum Housing Shoulder Diameter		
					Shaft	Housing	Plain Rings	Rib Rings	Plain Rings	Rib Rings	
	Inch/mm										
7328	7.153 181.69	10.161 258.09	7.755 196.98	9.620 244.35	0.312 7.92	0.125 3.18	6.77 172.0	7.15 181.6	10.68 271.3	10.16 258.1	7328
5328	7.153 181.69	10.161 258.09	7.755 196.98	9.620 244.35	0.312 7.92	0.125 3.18	6.77 172.0	7.15 181.6	10.68 271.3	10.16 258.1	5328
1930	6.510 165.35	7.669 194.79	6.741 171.22	7.438 188.93	0.125 3.18	0.080 2.03	6.36 161.5	6.51 165.4	7.84 199.1	7.66 194.6	1930
1030	6.641 168.68	8.128 206.45	6.937 176.20	7.832 198.93	0.156 3.96	0.080 2.03	6.47 164.3	6.64 168.7	8.36 212.3	8.12 206.2	1030
5030	6.643 168.73	8.128 206.45	6.937 176.20	7.832 198.93	0.156 3.96	0.080 2.03	6.47 164.3	6.64 168.7	8.36 212.3	8.12 206.2	5030
1230	7.147 181.53	9.522 241.86	7.600 193.04	9.095 231.01	0.250 6.35	0.100 2.54	6.86 174.2	7.14 181.4	9.88 251.0	9.52 241.8	1230
5230	7.147 181.53	9.522 241.86	7.600 193.04	9.095 231.01	0.250 6.35	0.100 2.54	6.86 174.2	7.14 181.4	9.88 251.0	9.52 241.8	5230
1330	7.516 190.91	10.992 279.20	8.210 208.53	10.367 263.32	0.312 7.92	0.125 3.18	7.13 181.1	7.51 190.8	11.50 292.1	10.99 279.1	1330
7330	7.516 190.91	10.992 279.20	8.210 208.53	10.367 263.32	0.312 7.92	0.125 3.18	7.13 181.1	7.51 190.8	11.50 292.1	10.99 279.1	7330
5330	7.516 190.91	10.992 279.20	8.210 208.53	10.367 263.32	0.312 7.92	0.125 3.18	7.13 181.1	7.51 190.8	11.50 292.1	10.99 279.1	5330
1932	6.905 175.39	8.064 204.83	7.136 181.25	7.833 198.96	0.125 3.18	0.080 2.03	6.76 171.7	6.90 175.3	8.24 209.3	8.06 204.7	1932
1032	7.084 179.93	8.669 220.19	7.400 187.96	8.353 212.17	0.156 3.96	0.080 2.03	6.91 175.5	7.08 179.8	8.92 226.6	8.66 220.0	1032
1232	7.623 193.62	10.225 259.72	8.105 205.87	9.757 247.83	0.250 6.35	0.100 2.54	7.31 185.7	7.62 193.5	10.61 269.5	10.22 259.6	1232
5232	7.623 193.62	10.225 259.72	8.105 205.87	9.757 247.83	0.250 6.35	0.100 2.54	7.31 185.7	7.62 193.5	10.61 269.5	10.22 259.6	5232
1332	8.106 205.89	11.582 294.18	8.800 223.52	10.958 278.33	0.375 9.52	0.125 3.18	7.70 195.6	8.10 205.7	12.16 308.9	11.58 294.1	1332
7332	8.106 205.89	11.582 294.18	8.800 223.52	10.958 278.33	0.375 9.52	0.125 3.18	7.70 195.6	8.10 205.7	12.16 308.9	11.58 294.1	7332
5332	8.106 205.89	11.582 294.18	8.800 223.52	10.958 278.33	0.375 9.52	0.125 3.18	7.70 195.6	8.10 205.7	12.16 308.9	11.58 294.1	5332
1934	7.300 185.42	8.459 214.86	7.531 191.29	8.228 208.99	0.125 3.18	0.080 2.03	7.15 181.6	7.30 185.4	8.63 219.2	8.45 214.6	1934
1034	7.615 193.42	9.319 236.70	7.955 202.06	8.980 228.09	0.187 4.75	0.080 2.03	7.41 188.2	7.61 193.3	9.61 244.1	9.31 236.5	1034

* The maximum fillet on the shaft or in the housing that the bearing corner will clear.

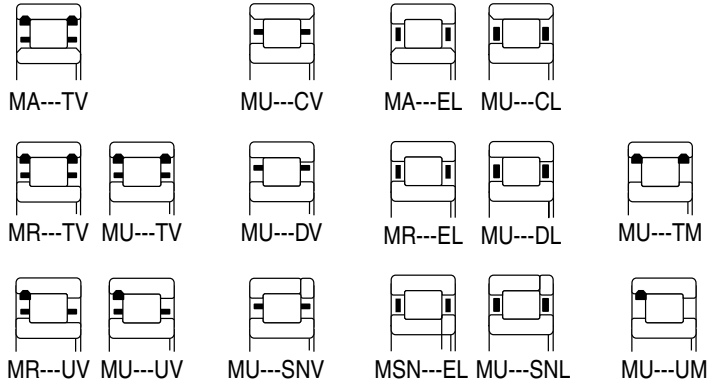
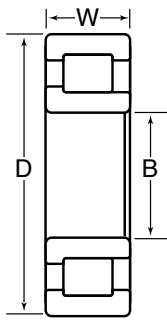

Basic Bearing Number	B		D		W		Radial Load Ratings — lbs./N								
	Bore Diameter	Outside Diameter		Width	One Piece Steel Cage				Composite Steel Cage		X Bar Steel Cage		Full Complement (No Cage)		
		Standard Style	"A" * Style		Outer Ring Assemblies		Inner Ring Assemblies		Dynamic	Static	Dynamic	Static	Dynamic	Static	
	Inch/mm				Dynamic	Static	Dynamic	Static							Dynamic
1234	6.6929 170.000	12.2047 310.000	12.2091 310.111	2.0472 52.000											
5234	6.6929 170.000	12.2047 310.000	12.2091 310.111	4.1250 104.775							260000 1160000	415000 1850000			
1334	6.6929 170.000	14.1732 360.000	14.1781 360.124	2.8346 72.000											
7334	6.6929 170.000	14.1732 360.000	14.1781 360.124	3.7402 95.000											
5334	6.6929 170.000	14.1732 360.000	14.1781 360.124	5.5000 139.700											
1936	7.0866 180.000	9.8425 250.000	9.8463 250.096	1.2992 33.000											
1036	7.0866 180.000	11.0236 280.000	11.0276 280.101	1.8110 46.000					95500 425000	148000 660000					
1236	7.0866 180.000	12.5984 320.000	12.6032 320.121	2.0472 52.000											
5236	7.0866 180.000	12.5984 320.000	12.6032 320.121	4.2500 107.950											
1336	7.0866 180.000	14.9606 380.000	14.9655 380.124	2.9528 75.000											
7336	7.0866 180.000	14.9606 380.000	14.9655 380.124	3.9370 100.000											
5336	7.0866 180.000	14.9606 380.000	14.9655 380.124	5.7500 146.050											
1938	7.4803 190.000	10.2362 260.000	10.2402 260.101	1.2992 33.000											
1038	7.4803 190.000	11.4173 290.000	11.4216 290.109	1.8110 46.000											
1238	7.4803 190.000	13.3858 340.000	13.3906 340.121	2.1654 55.000											
5238	7.4803 190.000	13.3858 340.000	13.3906 340.121	4.5000 114.300											
1338	7.4803 190.000	15.7480 400.000	15.7529 400.124	3.0709 78.000											
7338	7.4803 190.000	15.7480 400.000	15.7529 400.124	4.1339 105.000											

* Oversize outer ring for heavy press fit in standard housing bore.

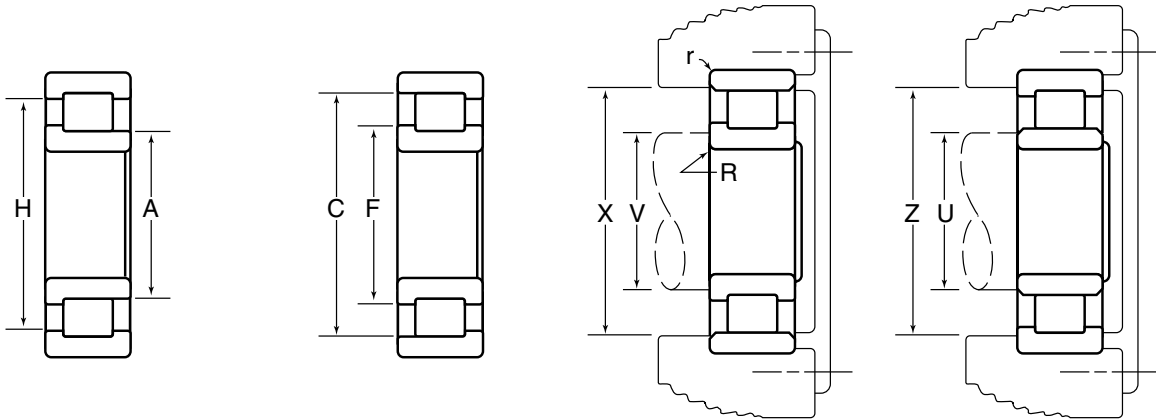

Basic Bearing Number	A	C	F	H	R	r	U	V	X	Z	Basic Bearing Number
	Inner Ring O.D.	Outer Ring I.D.	Inner Ring Rib O.D.	Outer Ring Rib I.D.	Maximum * Fillet Radius		Minimum Shaft Shoulder Diameter		Maximum Housing Shoulder Diameter		
					Shaft	Housing	Plain Rings	Rib Rings	Plain Rings	Rib Rings	
	Inch/mm										
1234	8.090 205.49	10.934 277.72	8.625 219.08	10.423 264.74	0.250 6.35	0.125 3.18	7.76 197.1	8.09 205.5	11.32 287.5	10.93 227.6	1234
5234	8.090 205.49	10.934 277.72	8.625 219.08	10.423 264.74	0.250 6.35	0.125 3.18	7.76 197.1	8.09 205.5	11.32 287.5	10.93 227.6	5234
1334	8.532 216.71	12.338 313.39	9.290 235.97	11.654 296.01	0.375 9.52	0.125 3.18	8.12 206.2	8.53 216.7	12.93 328.4	12.33 313.2	1334
7334	8.532 216.71	12.338 313.39	9.290 235.97	11.654 296.01	0.375 9.52	0.125 3.18	8.12 206.2	8.53 216.7	12.93 328.4	12.33 313.2	7334
5334	8.532 216.71	12.338 313.39	9.290 235.97	11.654 296.01	0.375 9.52	0.125 3.18	8.12 206.2	8.53 216.7	12.93 328.4	12.33 313.2	5334
1936	7.780 197.61	9.159 232.64	8.055 204.60	8.885 225.68	0.156 3.96	0.080 2.03	7.60 193.0	7.78 197.6	9.38 238.3	9.15 232.4	1936
1036	8.094 205.59	10.022 254.56	8.478 215.34	9.638 244.81	0.187 4.75	0.080 2.03	7.86 199.6	8.09 205.5	10.35 262.9	10.02 254.5	1036
1236	8.515 216.28	11.360 288.54	9.050 229.87	10.849 275.56	0.250 6.35	0.125 3.18	8.17 207.5	8.51 216.2	11.74 298.2	11.36 288.5	1236
5236	8.515 216.28	11.360 288.54	9.050 229.87	10.849 275.56	0.250 6.35	0.125 3.18	8.17 207.5	8.51 216.2	11.74 298.2	11.36 288.5	5236
1336	9.123 231.72	12.930 328.42	9.885 251.08	12.246 311.05	0.375 9.52	0.125 3.18	8.63 219.2	9.12 231.6	13.60 345.4	12.93 328.4	1336
7336	9.123 231.72	12.930 328.42	9.885 251.08	12.246 311.05	0.375 9.52	0.125 3.18	8.63 219.2	9.12 231.6	13.60 345.4	12.93 328.4	7336
5336	9.123 231.72	12.930 328.42	9.885 251.08	12.246 311.05	0.375 9.52	0.125 3.18	8.63 219.2	9.12 231.6	13.60 345.4	12.93 328.4	5336
1938	8.178 207.72	9.558 242.77	9.453 214.71	9.283 235.79	0.156 3.96	0.080 2.03	7.99 202.9	8.17 207.5	9.78 248.4	9.55 242.6	1938
1038	8.488 215.60	10.416 264.57	8.872 225.35	10.032 254.81	0.187 4.75	0.080 2.03	8.25 209.6	8.48 215.4	10.74 272.8	10.41 264.4	1038
1238	9.013 228.93	12.023 305.38	9.580 243.33	11.482 291.64	0.312 7.92	0.125 3.18	8.67 220.2	9.01 228.9	12.46 316.5	12.02 305.3	1238
5238	9.013 228.93	12.023 305.38	9.580 243.33	11.482 291.64	0.312 7.92	0.125 3.18	8.67 220.2	9.01 228.9	12.46 316.5	12.02 305.3	5238
1338	9.534 242.16	13.699 347.95	10.365 263.27	12.951 328.96	0.375 9.52	0.156 3.96	9.04 229.6	9.53 242.1	14.07 357.4	13.69 347.7	1338
7338	9.534 242.16	13.699 347.95	10.365 263.27	12.951 328.96	0.375 9.52	0.156 3.96	9.04 229.6	9.53 242.1	14.07 357.4	13.69 347.7	7338

* The maximum fillet on the shaft or in the housing that the bearing corner will clear.

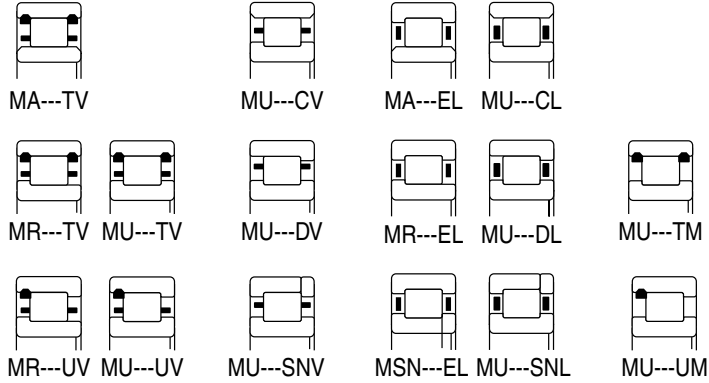
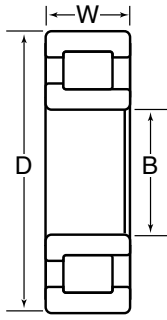

Basic Bearing Number	B		D		W		Radial Load Ratings — lbs./N							
	Bore Diameter	Outside Diameter		Width	One Piece Steel Cage				Composite Steel Cage		X Bar Steel Cage		Full Complement (No Cage)	
		Standard Style	"A" * Style		Outer Ring Assemblies		Inner Ring Assemblies		Dynamic	Static	Dynamic	Static	Dynamic	Static
					Dynamic	Static	Dynamic	Static						
Inch/mm					Dynamic	Static	Dynamic	Static	Dynamic	Static	Dynamic	Static		
5338	7.4803 190.000	15.7480 400.000	15.7529 400.124	6.0000 152.400										
1940	7.8740 200.000	11.0236 280.000	11.0276 280.101	1.4961 38.000										
1040	7.8740 200.000	12.2047 310.000	12.2091 310.111	2.0079 51.000										
1240	7.8740 200.000	14.1732 360.000	14.1781 360.124	2.2835 58.000										
5240	7.8740 200.000	14.1732 360.000	14.1781 360.124	4.7500 120.650										
1340	7.8740 200.000	16.5354 420.000	16.5406 420.131	3.1496 80.000										
7340	7.8740 200.000	16.5354 420.000	16.5406 420.131	4.2913 109.000										
5340	7.8740 200.000	16.5354 420.000	16.5406 420.131	6.5000 165.100										
1944	8.6614 220.000	11.8110 300.000	11.8154 300.111	1.4961 38.000										
1044	8.6614 220.000	13.3858 340.000	13.3906 340.121	2.2047 56.000										
1244	8.6614 220.000	15.7480 400.000	15.7529 400.124	2.5591 65.000										
5244	8.6614 220.000	15.7480 400.000	15.7529 400.124	5.2500 133.350										
1948	9.4488 240.000	12.5984 320.000	12.6032 320.121	1.4961 38.000										
1048	9.4488 240.000	14.1732 360.000	14.1781 360.124	2.2047 56.000						142000 635000	241000 1070000			
1248	9.4488 240.000	17.3228 440.000	17.3280 440.131	2.8346 72.000										
5248	9.4488 240.000	17.3228 440.000	17.3280 440.131	5.7500 146.050										
1952	10.2362 260.000	14.1732 360.000	14.1781 360.124	1.8110 46.000										
1052	10.2362 260.000	15.7480 400.000	15.7529 400.124	2.5591 65.000										

* Oversize outer ring for heavy press fit in standard housing bore.

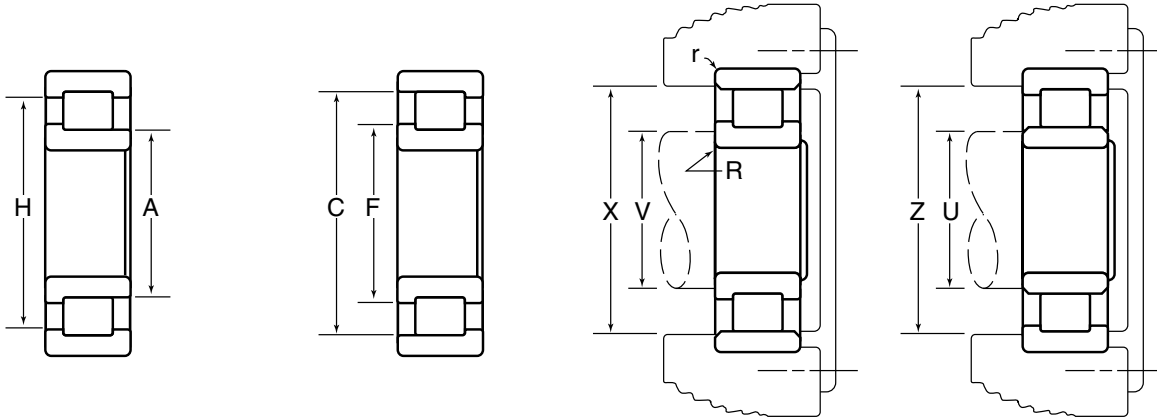

Basic Bearing Number	A	C	F	H	R	r	U	V	X	Z	Basic Bearing Number
	Inner Ring O.D.	Outer Ring I.D.	Inner Ring Rib O.D.	Outer Ring Rib I.D.	Maximum * Fillet Radius		Minimum Shaft Shoulder Diameter		Maximum Housing Shoulder Diameter		
					Shaft	Housing	Plain Rings	Rib Rings	Plain Rings	Rib Rings	
Inch/mm											
5338	9.534 242.16	13.699 347.95	10.365 263.27	12.951 328.96	0.375 9.52	0.156 3.96	9.04 229.6	9.53 242.1	14.07 357.4	13.69 347.7	5338
1940	8.660 219.96	10.246 260.25	8.976 227.99	9.930 252.22	0.187 4.75	0.080 2.03	8.48 215.4	8.66 220.0	10.49 266.4	10.24 260.1	1940
1040	8.964 227.69	11.122 282.50	9.394 238.61	10.692 271.58	0.187 4.75	0.080 2.03	8.70 221.0	8.96 227.6	11.47 291.3	11.12 282.4	1040
1240	9.535 242.19	12.703 322.66	10.135 257.43	12.134 308.20	0.312 7.92	0.125 3.18	9.15 232.4	9.53 242.1	13.17 334.5	12.70 322.6	1240
5240	9.535 242.19	12.703 322.66	10.135 257.43	12.134 308.20	0.312 7.92	0.125 3.18	9.15 232.4	9.53 242.1	13.17 334.5	12.70 322.6	5240
1340	10.125 257.18	14.290 362.97	10.955 278.26	13.542 343.97	0.375 9.52	0.156 3.96	9.57 243.1	10.12 257.0	14.72 373.9	14.29 363.0	1340
7340	10.125 257.18	14.290 362.97	10.955 278.26	13.542 343.97	0.375 9.52	0.156 3.96	9.57 243.1	10.12 257.0	14.72 373.9	14.29 363.0	7340
5340	10.125 257.18	14.290 362.97	10.955 278.26	13.542 343.97	0.375 9.52	0.156 3.96	9.57 243.1	10.12 257.0	14.72 373.9	14.29 363.0	5340
1944	9.450 240.03	11.037 280.34	9.766 248.06	10.721 272.31	0.187 4.75	0.080 2.03	9.27 235.5	9.45 240.0	11.28 286.5	11.03 280.2	1944
1044	9.898 251.41	12.156 308.76	10.348 262.84	11.706 297.33	0.250 6.35	0.100 2.54	9.62 244.3	9.89 251.2	12.55 318.8	12.15 308.6	1044
1244	10.469 265.91	14.138 359.11	11.201 284.51	13.479 342.37	0.375 9.52	0.125 3.18	10.08 256.0	10.46 265.7	14.65 372.1	14.13 358.9	1244
5244	10.469 265.91	14.138 359.11	11.201 284.51	13.479 342.37	0.375 9.52	0.125 3.18	10.08 256.0	10.46 265.7	14.65 372.1	14.13 358.9	5244
1948	10.236 259.99	11.823 300.30	10.552 268.02	11.508 292.30	0.187 4.75	0.080 2.03	10.05 255.3	10.23 259.8	12.07 306.6	11.82 300.2	1948
1048	10.685 271.40	12.944 328.78	11.135 282.83	12.494 317.35	0.250 6.35	0.100 2.54	10.40 264.2	10.68 271.3	13.37 339.6	12.94 328.7	1048
1248	11.464 291.19	15.482 393.24	12.266 311.56	14.760 374.90	0.375 9.52	0.125 3.18	11.00 279.4	11.46 291.1	16.08 408.4	15.48 393.2	1248
5248	11.464 291.19	15.482 393.24	12.266 311.56	14.760 374.90	0.375 9.52	0.125 3.18	11.00 279.4	11.46 291.1	16.08 408.4	15.48 393.2	5248
1952	11.250 285.75	13.180 334.77	11.634 295.50	12.796 325.02	0.281 7.14	0.080 2.03	11.01 279.7	11.25 285.8	13.50 342.9	13.18 334.8	1952
1052	11.651 295.94	14.341 364.26	12.187 309.55	13.806 350.67	0.312 7.92	0.125 3.18	11.35 288.3	11.65 295.9	14.82 376.4	14.34 364.2	1052

* The maximum fillet on the shaft or in the housing that the bearing corner will clear.

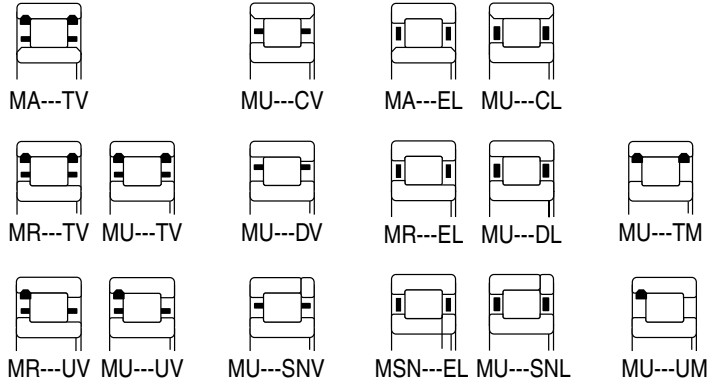
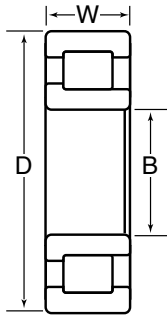

Basic Bearing Number	B	D		W	Radial Load Ratings — lbs./N												
		Bore Diameter	Outside Diameter		One Piece Steel Cage				Composite Steel Cage		X Bar Steel Cage		Full Complement (No Cage)				
	Inch/mm		Standard Style	"A" * Style	Width	Outer Ring Assemblies		Inner Ring Assemblies		Dynamic	Static	Dynamic	Static	Dynamic	Static	Dynamic	Static
		Dynamic				Static	Dynamic	Static									
1252	10.2362 260.000	18.8976 480.000	18.9029 480.134	3.1496 80.000													
5252	10.2362 260.000	18.8976 480.000	18.9029 480.134	6.2500 158.750													
1956	11.0236 280.000	14.9606 380.000	14.9655 380.124	1.8110 46.000			129000 575000	230000 1020000	132000 590000	238000 1060000							
1056	11.0236 280.000	16.5354 420.000	16.5406 420.131	2.5591 65.000													
1256	11.0236 280.000	19.6850 500.000	19.6903 500.134	3.1496 80.000													
5256	11.0236 280.000	19.6850 500.000	19.6903 500.134	6.5000 165.100													
1960	11.8110 300.000	16.5354 420.000	16.5406 420.131	2.2047 56.000													
1964	12.5984 320.000	17.3228 440.000	17.3280 440.131	2.2047 56.000													

* Oversize outer ring for heavy press fit in standard housing bore.

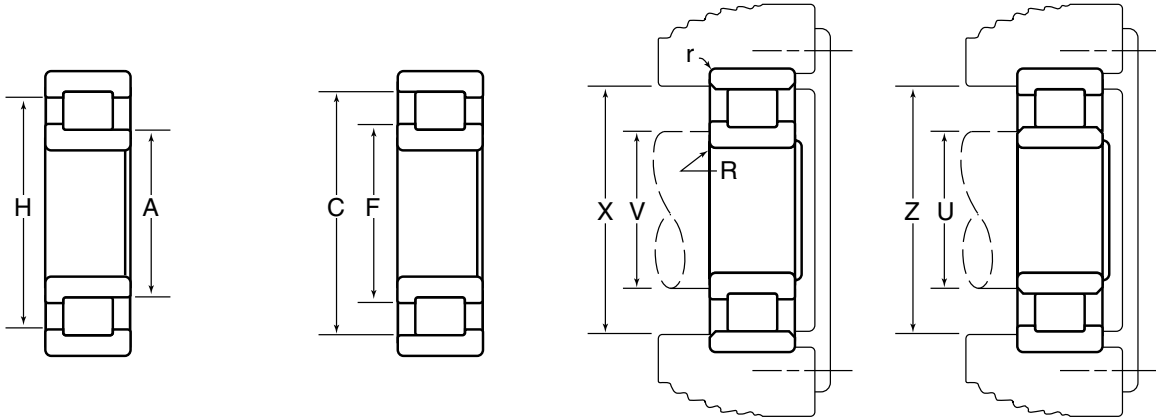

Basic Bearing Number	A	C	F	H	R	r	U	V	X	Z	Basic Bearing Number
	Inner Ring O.D.	Outer Ring I.D.	Inner Ring Rib O.D.	Outer Ring Rib I.D.	Maximum * Fillet Radius		Minimum Shaft Shoulder Diameter		Maximum Housing Shoulder Diameter		
					Shaft	Housing	Plain Rings	Rib Rings	Plain Rings	Rib Rings	
	Inch/mm										
1252	12.543	16.928	13.419	16.140	0.375	0.156	11.97	12.54	17.56	16.92	1252
	318.59	429.97	340.84	409.96	9.52	3.96	304.0	318.5	446.0	429.8	
5252	12.543	16.928	13.419	16.140	0.375	0.156	11.97	12.54	17.56	16.92	5252
	318.59	429.97	340.84	409.96	9.52	3.96	304.0	318.5	446.0	429.8	
1956	12.040	13.970	12.424	13.586	0.281	0.080	11.80	12.04	14.29	13.97	1956
	305.82	354.84	315.57	345.08	7.14	2.03	299.7	305.8	363.0	354.8	
1056	12.438	15.129	12.974	14.593	0.312	0.125	12.14	12.43	15.61	15.12	1056
	315.93	384.28	329.54	370.66	7.92	3.18	308.4	315.7	396.5	384.0	
1256	13.203	17.589	14.079	16.801	0.375	0.156	12.67	13.20	18.26	17.58	1256
	335.36	446.76	357.61	426.75	9.52	3.96	321.8	335.3	463.8	446.5	
5256	13.203	17.589	14.079	16.801	0.375	0.156	12.67	13.20	18.26	17.58	5256
	335.36	446.76	357.61	426.75	9.52	3.96	321.8	335.3	463.8	446.5	
1960	13.050	15.310	13.500	14.861	0.312	0.100	12.77	13.05	15.72	15.31	1960
	331.47	388.87	342.90	377.47	7.92	2.54	324.4	331.5	399.3	388.9	
1964	13.840	16.101	14.290	15.652	0.312	0.100	13.56	13.84	16.51	16.10	1964
	351.54	408.97	362.97	397.56	7.92	2.54	344.4	351.5	419.4	408.9	

* The maximum fillet on the shaft or in the housing that the bearing corner will clear.

**MAX-PAK
(Maximum Capacity)
W60000 Series**

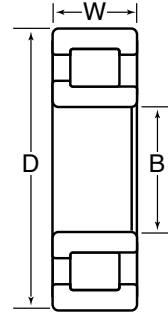

Basic Bearing Number	B		D		W	Radial Load Ratings — lbs./N								
	Bore Diameter	Outside Diameter		Width	One Piece Steel Cage				Composite Steel Cage		X Bar Steel Cage		Full Complement (No Cage)	
		Standard Style	"A" * Style		Outer Ring Assemblies		Inner Ring Assemblies		Dynamic	Static	Dynamic	Static	Dynamic	Static
	Inch/mm				Dynamic	Static	Dynamic	Static						
61007	1.3780 35.000	2.4409 62.000	2.4421 62.029	0.5512 14.000										
61207	1.3780 35.000	2.8346 72.000	2.8359 72.032	0.6693 17.000			11200 50000	11100 49500						
67207	1.3780 35.000	2.8346 72.000	2.8359 72.032	0.7480 19.000										
61307	1.3780 35.000	3.1496 80.000	3.1510 80.035	0.8268 21.000						15600 69500	14800 66000	17500 77500	17300 77000	
67307	1.3780 35.000	3.1496 80.000	3.1510 80.035	1.0236 26.000								22600 100000	24000 107000	
61008	1.5748 40.000	2.6772 68.000	2.6785 68.034	0.5906 15.000										
61208	1.5748 40.000	3.4196 80.000	3.1510 80.035	0.7087 18.000			13000 58000	12900 57000						
67208	1.5748 40.000	3.4196 80.000	3.1510 80.035	0.8268 21.000	15700 70000	16400 73000	15700 70000	16400 73000						
61308	1.5748 40.000	3.5433 90.000	3.5449 90.040	0.9055 23.000			18600 83000	17900 79500				20900 93000	20900 93000	
67308	1.5748 40.000	3.5433 90.000	3.5449 90.040	1.1811 30.000			25400 113000	26800 119000				28500 127000	31000 138000	
61009	1.7717 45.000	2.9528 75.000	2.9542 75.037	0.6299 16.000										
61209	1.7717 45.000	3.3465 85.000	3.3480 85.039	0.7480 19.000			14700 65500	15300 68000		14700 65500	15300 68000			
67209	1.7717 45.000	3.3465 85.000	3.3480 85.039	0.9055 23.000										
61309	1.7717 45.000	3.9370 100.000	3.9388 100.046	0.9843 25.000			23600 105000	23100 103000		23600 105000	23100 103000			
67309	1.7717 45.000	3.9370 100.000	3.9388 100.046	1.2205 31.000										
61010	1.9685 50.000	3.4196 80.000	3.1510 80.035	0.6299 16.000										
61210	1.9685 50.000	3.5433 90.000	3.5449 90.040	0.7874 20.000			16200 72000	17700 78500		16200 72000	17700 78500			
67210	1.9685 50.000	3.5433 90.000	3.5449 90.040	0.9055 23.000			19100 85000	21900 97500		19100 85000	21900 97500			

* Oversize outer ring for heavy press fit in standard housing bore.

**MAX-PAK
(Maximum Capacity)
W60000 Series**

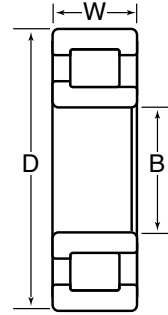

Basic Bearing Number	B		D		W	Radial Load Ratings — lbs./N											
	Bore Diameter	Outside Diameter		Width		One Piece Steel Cage				Composite Steel Cage		X Bar Steel Cage		Full Complement (No Cage)			
		Standard Style	"A" * Style			Outer Ring Assemblies		Inner Ring Assemblies		Dynamic	Static	Dynamic	Static	Dynamic	Static	Dynamic	Static
		Inch/mm				Dynamic	Static	Dynamic	Static								
61310	1.9685 50.000	4.3307 110.000	4.3329 110.056	1.0630 27.000													
67310	1.9685 50.000	4.3307 110.000	4.3329 110.056	1.2992 33.000													
61911	2.1654 55.000	3.4196 80.000	3.1510 80.035	0.5118 13.000													
61011	2.1654 55.000	3.5433 90.000	3.5449 90.040	0.7087 18.000								13900 62000	15900 71000				
61211	2.1654 55.000	3.9370 100.000	3.9388 100.046	0.8268 21.000			19400 86500	21200 94000				13900 62000	15900 71000				
67211	2.1654 55.000	3.9370 100.000	3.9388 100.046	0.9843 25.000	23900 106000	27700 123000	23900 106000	27700 123000				23900 106000	27700 123000				
61311	2.1654 55.000	4.7244 120.000	4.7266 120.056	1.1417 29.000													
67311	2.1654 55.000	4.7244 120.000	4.7266 120.056	1.4173 36.000								42500 189000	47500 212000				
61912	2.3622 60.000	3.3465 85.000	3.3480 85.039	0.5118 13.000													
61012	2.3622 60.000	3.7402 95.000	3.7419 95.044	0.7087 18.000													
61212	2.3622 60.000	4.3307 110.000	4.3329 110.056	0.8661 22.000			22300 99000	24200 107000				22300 99000	24200 107000				
67212	2.3622 60.000	4.3307 110.000	4.3329 110.056	1.0630 27.000	28300 126000	33000 146000	28300 126000	33000 146000				28300 126000	33000 146000				
65212	2.3622 60.000	4.3307 110.000	4.3329 110.056	1.4375 36.512			39000 174000	50000 222000									
61312	2.3622 60.000	5.1181 130.000	5.1204 130.058	1.2205 31.000								37000 164000	37500 167000				
67312	2.3622 60.000	5.1181 130.000	5.1204 130.058	1.4961 38.000								47000 208000	51000 226000				
61913	2.5591 65.000	3.5433 90.000	3.5449 90.040	0.5118 13.000													
61013	2.5591 65.000	3.9370 100.000	3.9388 100.046	0.7087 18.000													
61213	2.5591 65.000	4.7244 120.000	4.7266 120.056	0.9055 23.000			25400 113000	27900 124000	25400 113000	27900 124000		25400 113000	27900 124000				

* Oversize outer ring for heavy press fit in standard housing bore.

**MAX-PAK
(Maximum Capacity)
W60000 Series**

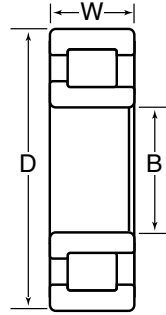

Basic Bearing Number	B		D		W	Radial Load Ratings — lbs./N								
	Bore Diameter	Outside Diameter		Width	One Piece Steel Cage				Composite Steel Cage		X Bar Steel Cage		Full Complement (No Cage)	
		Standard Style	"A" * Style		Outer Ring Assemblies		Inner Ring Assemblies		Dynamic	Static	Dynamic	Static	Dynamic	Static
	Inch/mm				Dynamic	Static	Dynamic	Static	Dynamic	Static	Dynamic	Static	Dynamic	Static
67213	2.5591 65.000	4.7244 120.000	4.7266 120.056	1.1417 29.000	32500 146000	38500 171000	32520 146000	38500 171000			32500 146000	38500 171000		
61313	2.5591 65.000	5.5118 140.000	5.5141 140.058	1.2992 33.000										
67313	2.5591 65.000	5.5118 140.000	5.5141 140.058	1.5748 40.000										
61914	2.7559 70.000	3.9370 100.000	3.9388 100.046	0.6299 16.000							13100 58500	17800 79000		
61014	2.7559 70.000	4.3307 110.000	4.3329 110.056	0.7874 20.000										
61214	2.7559 70.000	4.9213 125.000	4.9236 125.059	0.9449 24.000			28100 125000	32500 144000			28100 125000	32500 144000		
67214	2.7559 70.000	4.9213 125.000	4.9236 125.059	1.2205 31.000										
61314	2.7559 70.000	5.9055 150.000	5.9081 150.066	1.3780 35.000							49500 219000	53000 236000		
67314	2.7559 70.000	5.9055 150.000	5.9081 150.066	1.6929 43.000			62000 275000	71000 315000			62000 275000	71000 315000		
61915	2.9528 75.000	4.1339 105.000	4.1358 105.049	0.6299 16.000			13400 59500	18600 82500						
61015	2.9528 75.000	4.5276 115.000	4.5298 115.057	0.7874 20.000										
61215	2.9528 75.000	5.1181 130.000	5.1204 130.058	0.9843 25.000			31000 137000	35500 158000			31000 137000	35500 158000		
67215	2.9528 75.000	5.1181 130.000	5.1204 130.058	1.2205 31.000	39000 174000	48500 215000	39000 174000	48500 215000			39000 174000	48500 215000		
68215	2.9528 75.000	5.1181 130.000	5.1204 130.058	1.4961 38.000							47000 209000	65000 289000		
61315	2.9528 75.000	6.2992 160.000	6.3020 160.071	1.4567 37.000										
67315	2.9528 75.000	6.2992 160.000	6.3020 160.071	1.8110 46.000	70000 310000	81000 360000	70000 310000	81000 360000			70000 310000	81000 360000		
61916	3.1496 80.000	4.3307 110.000	4.3329 110.056	0.6299 16.000			14000 62500	20100 89000						
61016	3.1496 80.000	4.9213 125.000	4.9236 125.059	0.8661 22.000										

* Oversize outer ring for heavy press fit in standard housing bore.

**MAX-PAK
(Maximum Capacity)
W60000 Series**

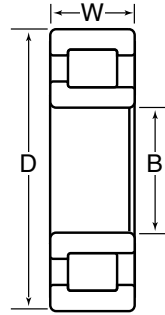

Basic Bearing Number	B		D		W	Radial Load Ratings — lbs./N											
	Bore Diameter	Outside Diameter		Width		One Piece Steel Cage				Composite Steel Cage		X Bar Steel Cage		Full Complement (No Cage)			
		Standard Style	"A" * Style			Outer Ring Assemblies	Inner Ring Assemblies	Dynamic	Static	Dynamic	Static	Dynamic	Static	Dynamic	Static	Dynamic	Static
61216	3.1496 80.000	5.5118 140.000	5.5141 140.058	1.0236 26.000			33500 150000	40000 178000			33500 150000	40000 178000					
67216	3.1496 80.000	5.5118 140.000	5.5141 140.058	1.2992 33.000			44500 199000	57500 256000			44500 199000	57500 256000					
61316	3.1496 80.000	6.6929 170.000	6.6957 170.071	1.5354 39.000			61000 271000	66500 295000									
67316	3.1496 80.000	6.6929 170.000	6.6957 170.071	1.9291 49.000													
61917	3.3465 85.000	4.7244 120.000	4.7266 120.056	0.7087 18.000													
61017	3.3465 85.000	5.1181 130.000	5.1204 130.058	0.8661 22.000													
61217	3.3465 85.000	5.9055 150.000	5.9081 150.066	1.1024 28.000													
67217	3.3465 85.000	5.9055 150.000	5.9081 150.066	1.3780 35.000	49500 220000	62500 279000	49500 220000	62500 279000			49500 220000	62500 279000					
61317	3.3465 85.000	7.0866 180.000	7.0894 180.071	1.6142 41.000													
67317	3.3465 85.000	7.0866 180.000	7.0894 180.071	2.0079 51.000													
61918	3.5433 90.000	4.9213 125.000	4.9236 125.059	0.7087 18.000			17600 78000	24500 109000	17600 78000	24500 109000	17600 78000	24500 109000					
61018	3.5433 90.000	5.5118 140.000	5.5141 140.058	0.9449 24.000	27800 124000	35000 156000	27800 124000	35000 156000			27800 124000	35000 156000					
61218	3.5433 90.000	6.2992 160.000	6.3020 160.071	1.1811 30.000			44500 199000	51500 228000									
67218	3.5433 90.000	6.2992 160.000	6.3020 160.071	1.4567 37.000	54500 241000	66000 293000	54500 241000	66000 293000			54500 241000	66000 293000					
61318	3.5433 90.000	7.4803 190.000	7.4833 190.076	1.6929 43.000													
67318	3.5433 90.000	7.4803 190.000	7.4833 190.076	2.1260 54.000													
61919	3.7402 95.000	5.1181 130.000	5.1204 130.058	0.7087 18.000			17900 79500	25500 113000									
61019	3.7402 95.000	5.7087 145.000	5.7113 145.067	0.9449 24.000	28700 128000	37000 165000					28700 128000	37000 165000					

* Oversize outer ring for heavy press fit in standard housing bore.

**MAX-PAK
(Maximum Capacity)
W60000 Series**

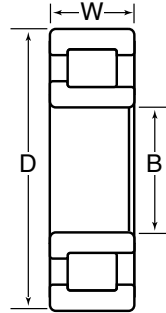

Basic Bearing Number	B		D		W	Radial Load Ratings — lbs./N								
	Bore Diameter	Outside Diameter		Width	One Piece Steel Cage				Composite Steel Cage		X Bar Steel Cage		Full Complement (No Cage)	
		Standard Style	"A" * Style		Outer Ring Assemblies		Inner Ring Assemblies		Dynamic	Static	Dynamic	Static	Dynamic	Static
	Inch/mm				Dynamic	Static	Dynamic	Static	Dynamic	Static	Dynamic	Static	Dynamic	Static
61219	3.7402 95.000	6.6929 170.000	6.6957 170.071	1.2598 32.000	48000 214000	57500 255000	48000 214000	57500 255000						
67219	3.7402 95.000	6.6929 170.000	6.6957 170.071	1.5354 39.000			61000 271000	78000 345000			61000 271000	78000 345000		
61319	3.7402 95.000	7.8740 200.000	7.8771 200.078	1.7717 45.000										
67319	3.7402 95.000	7.8740 200.000	7.8771 200.078	2.2047 56.000										
61920	3.9370 100.000	5.5118 140.000	5.5141 140.058	0.7874 20.000			22000 98000	31500 139000			22000 98000	31500 139000		
61020	3.9370 100.000	5.9055 150.000	5.9081 150.066	0.9449 24.000										
61220	3.9370 100.000	7.0866 180.000	7.0894 180.071	1.3386 34.000										
67220	3.9370 100.000	7.0866 180.000	7.0894 180.071	1.6142 41.000	69500 310000	86000 385000	69500 310000	86000 385000			69500 310000	86000 385000		
68220	3.9370 100.000	7.0866 180.000	7.0894 180.071	2.0866 53.000							91500 405000	123000 550000		
61320	3.9370 100.000	8.4646 215.000	8.4680 215.087	1.8504 47.000										
67320	3.9370 100.000	8.4646 215.000	8.4680 215.087	2.3622 60.000			121000 535000	144000 640000			121000 535000	144000 640000		
61921	4.1339 105.000	5.7087 145.000	5.7113 145.067	0.7874 20.000										
61021	4.1339 105.000	6.2992 160.000	6.3020 160.071	1.0236 26.000										
61221	4.1339 105.000	7.4803 190.000	7.4833 190.076	1.4173 36.000										
67221	4.1339 105.000	7.4803 190.000	7.4833 190.076	1.6929 43.000			76000 340000	98500 440000			76000 340000	98500 440000		
61321	4.1339 105.000	8.8583 225.000	8.8618 225.090	1.9291 49.000										
67321	4.1339 105.000	8.8583 225.000	8.8618 225.090	2.4803 63.000										
61922	4.3307 110.000	5.9055 150.000	5.9081 150.066	0.7874 20.000									26300 117000	40500 181000

* Oversize outer ring for heavy press fit in standard housing bore.

**MAX-PAK
(Maximum Capacity)
W60000 Series**

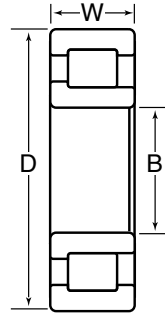

Basic Bearing Number	B		D		W	Radial Load Ratings — lbs./N									
	Bore Diameter	Outside Diameter		Width	One Piece Steel Cage				Composite Steel Cage		X Bar Steel Cage		Full Complement (No Cage)		
		Standard Style	"A" * Style		Outer Ring Assemblies		Inner Ring Assemblies		Dynamic	Static	Dynamic	Static	Dynamic	Static	Dynamic
	Inch/mm				Dynamic	Static	Dynamic	Static	Dynamic	Static	Dynamic	Static	Dynamic	Static	
61022	4.3307 110.000	6.6929 170.000	6.6957 170.071	1.1024 28.000											
61222	4.3307 110.000	7.8740 200.000	7.8771 200.078	1.4961 38.000											
67222	4.3307 110.000	7.8740 200.000	7.8771 200.078	1.7717 45.000			83500 370000	105000 465000			83500 370000	105000 465000			
62222	4.3307 110.000	7.8740 200.000	7.8771 200.078	2.0866 53.000							101000 450000	134000 595000			
61322	4.3307 110.000	9.4488 240.000	9.4526 240.096	1.9685 50.000											
67322	4.3307 110.000	9.4488 240.000	9.4526 240.096	2.5591 65.000											
61924	4.7244 120.000	6.4961 165.000	6.4989 165.072	0.8661 22.000											
61024	4.7244 120.000	7.0866 180.000	7.0894 180.071	1.1024 28.000							43000 191000	57500 257000			
61224	4.7244 120.000	8.4646 215.000	8.4680 215.087	1.5748 40.000							75500 335000	93000 415000			
67224	4.7244 120.000	8.4646 215.000	8.4680 215.087	1.8504 47.000											
68224	4.7244 120.000	8.4646 215.000	8.4680 215.087	2.3622 60.000			120000 535000	169000 750000							
61324	4.7244 120.000	10.2362 260.000	10.2402 260.101	2.1654 55.000											
67324	4.7244 120.000	10.2362 260.000	10.2402 260.101	2.7953 71.000											
61926	5.1181 130.000	7.0866 180.000	7.0894 180.071	0.9449 24.000			34000 152000	50500 225000			34000 152000	50500 225000			
61026	5.1181 130.000	7.8470 200.000	7.8771 200.078	1.2992 33.000											
61226	5.1181 130.000	9.0551 230.000	9.0587 230.091	1.5748 40.000											
67226	5.1181 130.000	9.0551 230.000	9.0587 230.091	1.9685 50.000			104000 460000	141000 625000							
61326	5.1181 130.000	11.0236 280.000	11.0276 280.101	2.2835 58.000											

* Oversize outer ring for heavy press fit in standard housing bore.

**MAX-PAK
(Maximum Capacity)
W60000 Series**

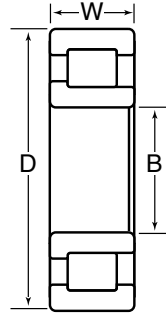

Basic Bearing Number	B		D		W	Radial Load Ratings — lbs./N									
	Bore Diameter	Outside Diameter		Width	One Piece Steel Cage				Composite Steel Cage		X Bar Steel Cage		Full Complement (No Cage)		
		Standard Style	"A" * Style		Outer Ring Assemblies		Inner Ring Assemblies		Dynamic	Static	Dynamic	Static	Dynamic	Static	Dynamic
	Inch/mm				Dynamic	Static	Dynamic	Static	Dynamic	Static	Dynamic	Static	Dynamic	Static	
67326	5.1181 130.000	11.0236 280.000	11.0276 280.101	2.9528 75.000											
61928	5.5118 140.000	7.4803 190.000	7.4833 190.076	0.9449 24.000			34500 154000	52500 233000			34500 154000	52500 233000			
61028	5.5118 140.000	8.2677 210.000	8.2709 210.081	1.2992 33.000											
61228	5.5118 140.000	9.8425 250.000	9.8463 250.096	1.6535 42.000			87500 390000	106000 470000			95500 425000	119000 530000			
67228	5.5118 140.000	9.8425 250.000	9.8463 250.096	2.1654 55.000											
61328	5.5118 140.000	11.8110 300.000	11.8154 300.111	2.4409 62.000											
67328	5.5118 140.000	11.8110 300.000	11.8154 300.111	3.2677 83.000											
61930	5.9055 150.000	8.2677 210.000	8.2709 210.081	1.1024 28.000											
61030	5.9055 150.000	8.8583 225.000	8.8618 225.090	1.3780 35.000											
61230	5.9055 150.000	10.6299 270.000	10.6339 270.101	1.7717 45.000											
67230	5.9055 150.000	10.6299 270.000	10.6339 270.101	2.2835 58.000											
61330	5.9055 150.000	12.5984 320.000	12.6032 320.121	2.5591 65.000											
67330	5.9055 150.000	12.5984 320.000	12.6032 320.121	3.4252 87.000											
61932	6.2992 160.000	8.6614 220.000	8.6649 220.088	1.1024 28.000			49500 221000	75500 335000							
61032	6.2992 160.000	9.4488 240.000	9.4526 240.096	1.4961 38.000			75500 335000	100000 445000							
61232	6.2992 160.000	11.4173 290.000	11.4216 290.109	1.8898 48.000			119000 530000	154000 685000							
67232	6.2992 160.000	11.4173 290.000	11.4216 290.109	2.4409 62.000											
61332	6.2992 160.000	13.3858 340.000	13.3906 340.121	2.6772 68.000											

* Oversize outer ring for heavy press fit in standard housing bore.

**MAX-PAK
(Maximum Capacity)
W60000 Series**

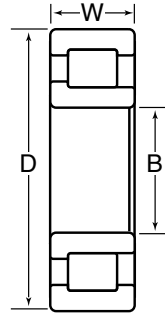

Basic Bearing Number	B		D		W	Radial Load Ratings — lbs./N							
	Bore Diameter	Outside Diameter		Width		One Piece Steel Cage		Composite Steel Cage		X Bar Steel Cage		Full Complement (No Cage)	
		Standard Style	"A" * Style			Outer Ring Assemblies	Inner Ring Assemblies	Dynamic	Static	Dynamic	Static	Dynamic	Static
	Inch/mm					Dynamic	Static	Dynamic	Static	Dynamic	Static	Dynamic	Static
67332	6.2992 160.000	13.3858 340.000	13.3906 340.121	3.5433 90.000									
61934	6.6929 170.000	9.0551 230.000	9.0587 230.091	1.1024 28.000									
61034	6.6929 170.000	10.2362 260.000	10.2402 260.101	1.6535 42.000									
61234	6.6929 170.000	12.2047 310.000	12.2091 310.111	2.0472 52.000									
67234	6.6929 170.000	12.2047 310.000	12.2091 310.111	2.4409 62.000									
61334	6.6929 170.000	14.1732 360.000	14.1781 360.124	2.8346 72.000									
67334	6.6929 170.000	14.1732 360.000	14.1781 360.124	3.7402 95.000									
61936	7.0866 180.000	9.8425 250.000	9.8463 250.096	1.2992 33.000			64500 287000	98000 435000					
61036	7.0866 180.000	11.0236 280.000	11.0276 280.101	1.8110 46.000			110000 490000	158000 705000	110000 490000	158000 705000			
61236	7.0866 180.000	12.5984 320.000	12.6032 320.121	2.0472 52.000									
67236	7.0866 180.000	12.5984 320.000	12.6032 320.121	2.5591 65.000									
61336	7.0866 180.000	14.9606 320.000	14.9655 380.124	2.9528 75.000									
67336	7.0866 180.000	14.9606 380.000	14.9655 380.124	3.9370 100.000									
61938	7.4803 190.000	10.2362 260.000	10.2402 260.101	1.2992 33.000			67500 300000	105000 470000	67500 300000	105000 470000			
61038	7.4803 190.000	11.4173 290.000	11.4216 290.109	1.8110 46.000			111000 495000	164000 730000					
61238	7.4803 190.000	13.3858 340.000	13.3906 340.121	2.1654 55.000			160000 710000	207000 925000					
67238	7.4803 190.000	13.3858 340.000	13.3906 340.121	2.6772 68.000									
61338	7.4803 190.000	15.7480 400.000	15.7529 400.124	3.0709 78.000									

* Oversize outer ring for heavy press fit in standard housing bore.

**MAX-PAK
(Maximum Capacity)
W60000 Series**

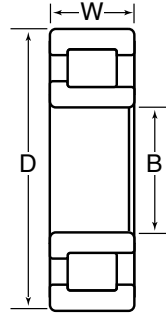

Basic Bearing Number	B		D		W	Radial Load Ratings — lbs./N											
	Bore Diameter	Outside Diameter		Width		One Piece Steel Cage				Composite Steel Cage		X Bar Steel Cage		Full Complement (No Cage)			
		Standard Style	"A" * Style			Outer Ring Assemblies		Inner Ring Assemblies		Dynamic	Static	Dynamic	Static	Dynamic	Static	Dynamic	Static
						Dynamic	Static	Dynamic	Static								
67338	7.4803 190.000	15.7480 400.000	15.7529 400.124	4.1339 105.000													
61940	7.8740 200.000	11.0236 280.000	11.0276 280.101	1.4961 38.000				83000 370000	130000 580000								
61040	7.8740 200.000	12.2047 310.000	12.2091 310.111	2.0079 51.000								131000 585000	194000 860000				
61240	7.8740 200.000	14.1732 360.000	14.1781 360.124	2.2835 58.000				180000 800000	236000 1050000								
67240	7.8740 200.000	14.1732 360.000	14.1781 360.124	2.8346 72.000													
61340	7.8740 200.000	16.5354 420.000	16.5406 420.131	3.1496 80.000													
67340	7.8740 200.000	16.5354 420.000	16.5406 420.131	4.2913 109.000													
61944	8.6614 220.000	11.8110 300.000	11.8154 300.111	1.4961 38.000				86000 385000	140000 625000								
61044	8.6614 220.000	13.3858 340.000	13.3906 340.121	2.2047 56.000				162000 720000	241000 1070000								
61244	8.6614 220.000	15.7480 400.000	15.7529 400.124	2.5591 65.000													
67244	8.6614 220.000	15.7480 400.000	15.7529 400.124	3.0709 78.000													
61948	9.4488 240.000	12.5984 320.000	12.6032 320.121	1.4961 38.000				89500 395000	151000 670000								
61048	9.4488 240.000	14.1732 360.000	14.1781 360.124	2.2047 56.000													
61248	9.4488 240.000	17.3228 440.000	17.3280 440.131	2.8346 72.000													
67248	9.4488 240.000	17.3228 440.000	17.3280 440.131	3.3465 85.000													
61952	10.2362 260.000	14.1732 360.000	14.1781 360.124	1.8110 46.000				128000 570000	213000 945000								
61052	10.2362 260.000	15.7480 400.000	15.7529 400.124	2.5591 65.000													
61252	10.2362 260.000	18.8976 480.000	18.9029 480.134	3.1496 80.000				330000 1470000	445000 1970000								

* Oversize outer ring for heavy press fit in standard housing bore.

**MAX-PAK
(Maximum Capacity)
W60000 Series**

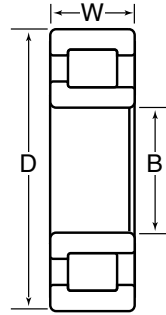

Basic Bearing Number	B		D		W	Radial Load Ratings — lbs./N									
	Bore Diameter	Outside Diameter		Width		One Piece Steel Cage				Composite Steel Cage		X Bar Steel Cage		Full Complement (No Cage)	
		Standard Style	"A" * Style			Outer Ring Assemblies	Inner Ring Assemblies	Dynamic	Static	Dynamic	Static	Dynamic	Static	Dynamic	Static
	Inch/mm					Dynamic	Static								
67252	10.2362	18.8976	18.9029	3.5433											
	260.000	480.000	480.134	90.000											
61956	11.0236	14.9606	14.9655	1.8110											
	280.000	380.000	380.124	46.000											
61056	11.0236	16.5354	16.5406	2.5591											
	280.000	420.000	420.131	65.000											
61256	11.0236	19.6850	19.6903	3.1496											
	280.000	500.000	500.134	80.000											
67256	11.0236	19.6850	19.6903	3.7402											
	280.000	500.000	500.134	95.000											
61960	11.8110	16.5354	16.5406	2.2047											
	300.000	420.000	420.131	56.000											
61964	12.5984	17.3228	17.3280	2.2047							195000	340000			
	320.000	440.000	440.131	56.000							870000	1520000			

* Oversize outer ring for heavy press fit in standard housing bore.

MOJ & MOX Style Cylindrical Roller Bearings

Economical MOJ and MOX roller bearings operate in a very limited space and are easily assembled and disassembled for servicing. The rollers run directly on the hardened and ground surfaces of the shaft and housing, which much have a hardness of Rockwell C58-64 and surface finish no greater than 18 AA to perform at their maximum capacity. Any deviation will result in a reduced load rating which should be discussed with the NTN Application Engineering Department.

MOJ and MOX bearings consist of the same roller complement and composite steel cage components used in the “M” or “W” series bearings.

A part number listing, load ratings, and dimensions are shown on the following pages. For availability and additional information contact NTN sales.

The final drive planetary in this rubber tired earth mover wheel is an ideal application for MOJ or MOX bearings, which must resist shock and carry very heavy radial loads at low speed.



MOJ



MOX

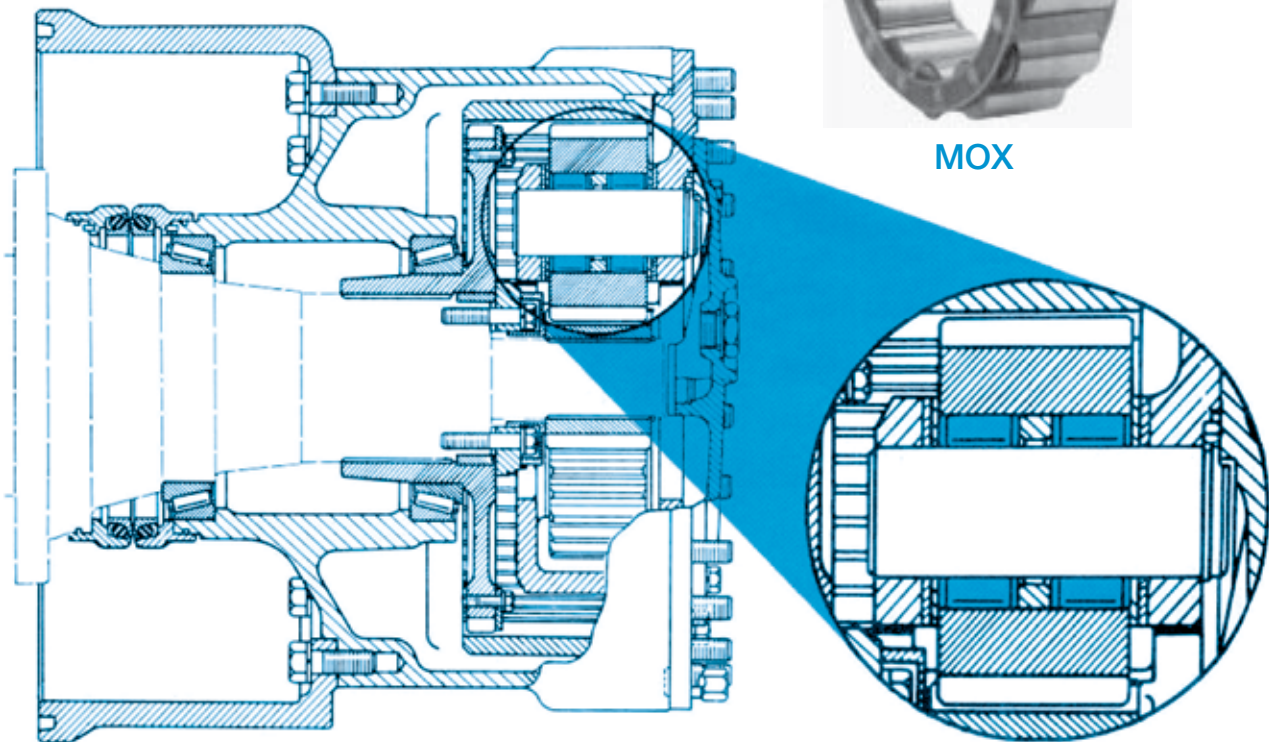

MOJ & MOX Style Bearings Dimensions and Load Ratings

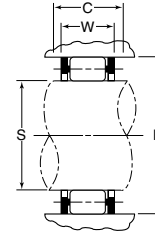

Roller Assembly Number	S	H	C	W	Radial Load Ratings	
	Maximum Shaft Diameter	Minimum Housing Bore	Minimum Operating Spac	Bearing Assembly Width	Dynamic	Static
	Inch/mm				lbs/N	
MOF-1212	2.8511	3.8468	0.891	0.827	18500	20700
	72.418	97.709	22.63	21.01	82500	92000
MOJ-1214	3.3392	4.3893	0.938	0.848	23200	27800
	84.816	11.488	23.83	21.54	103000	124000
MOJ-1316	4.0031	5.8012	1.375	1.315	54000	62000
	101.679	147.350	34.92	33.40	241000	276000
MOX-1318	4.5026	6.5234	1.563	1.457	68500	80000
	114.366	165.694	39.70	37.01	305000	355000
MOJ-5206	1.4994	2.1283	0.875	0.800	12500	14200
	38.085	54.059	22.22	20.32	55500	63000
MOJ-5214	3.3392	4.3893	1.406	1.328	38000	53000
	84.816	111.488	35.71	33.73	170000	235000
MOJ-5216	3.7532	4.9076	1.531	1.463	46500	66000
	95.331	124.653	38.89	37.16	207000	294000
* MOJ-5216-A	3.7532	4.9076	1.531	1.463	46500	66000
	95.331	124.653	38.89	37.16	207000	294000
MOV-5304	1.1013	1.7314	0.925	0.831	9150	8950
	27.973	43.978	23.50	21.11	40500	40000
MOJ-5308	2.0600	3.0557	1.281	1.210	27800	32500
	52.324	77.615	32.54	30.73	124000	145000
MOX-5308-A	2.0600	3.0557	1.250	1.153	26300	30000
	52.324	77.615	31.75	29.29	117000	134000
MOJ-5309	2.3382	3.3883	1.438	1.363	32000	39000
	59.390	86.063	36.52	34.62	143000	173000
MOJ-5310	2.5660	3.7187	1.500	1.441	37500	46000
	65.176	94.455	38.10	36.60	167000	204000
MOJ-5311	2.8136	4.0775	1.656	1.603	49000	62500
	71.465	103.569	42.06	40.72	218000	277000
MOJ-5315	3.7780	5.4773	2.344	2.283	87000	117000
	95.961	139.123	59.54	57.99	390000	520000
MOX-5316-A	4.0031	5.8039	2.266	2.205	90000	119000
	101.679	147.419	57.56	56.01	400000	530000
MOJ-7305	1.3383	2.1034	0.750	0.715	11300	11000
	33.993	53.426	19.05	18.16	50500	49000
MOJ-7309	2.3381	3.3882	1.172	1.129	26300	30000
	59.388	86.060	29.77	28.68	117000	134000
MOJ-7312	3.0545	4.4264	1.406	1.330	42500	50000
	77.584	112.431	35.71	33.78	188000	222000
MOX-7312-N	3.0545	4.4264	1.406	1.330	44500	53500
	77.584	112.431	35.71	33.78	198000	238000
MOX-7312-A	3.0545	4.4264	1.406	1.330	42500	50000
	77.584	112.431	35.71	33.78	188000	222000
MOX-7312-B	3.0545	4.4264	1.406	1.330	42500	50000
	77.584	112.431	35.71	33.78	188000	222000
MOJ-7314	3.5132	5.0911	1.594	1.495	54500	65500
	89.235	129.314	40.49	37.97	242000	291000

* Special crown roller

MOJ & MOX Style Bearings Dimensions and Load Ratings

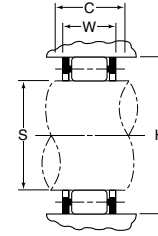

Roller Assembly Number	S	H	C	W	Radial Load Ratings	
	Maximum Shaft Diameter	Minimum Housing Bore	Minimum Operating Spac	Bearing Assembly Width	Dynamic	Static
	Inch/mm				lbs/N	
MOJ-7314-A	3.5132 89.235	5.0911 129.314	1.594 40.49	1.495 37.97	54500 242000	65500 291000
MOJ-7316	4.0031 101.679	5.8039 147.419	1.781 45.24	1.695 43.05	71500 320000	89000 395000
MOX-7316-B	4.0031 101.679	5.8009 147.343	1.781 45.24	1.705 43.31	70500 315000	87000 385000
MOX-7316-C	4.0031 101.679	5.8039 147.419	1.781 45.24	1.720 43.69	70500 315000	87000 385000
MOX-12876	4.0182 102.062	6.3390 162.535	2.406 61.11	2.330 59.18		
WOX-67311	2.7748 70.480	4.2333 107.526	1.422 36.12	1.334 33.88	42500 189000	47500 212000
WOX-67314	3.4919 88.694	5.3200 135.128	1.688 42.88	1.616 41.05	62000 275000	71000 315000
WOX-67320	4.9584 125.943	7.6298 193.797	2.283 57.99	2.204 55.98	122000 540000	146000 650000
J-36-1632	1.1250 28.575	1.6255 41.288	1.000 25.40	0.954 24.23	11200 50000	13400 59500
J-36-1656	1.1250 28.575	1.6255 41.288	1.750 44.45	1.691 42.95	19300 86000	26800 119000
J-36-3236	1.1250 28.575	2.1255 53.988	1.125 28.58	1.080 27.43	15800 70000	14300 63500
JV-44-1419	1.3750 34.925	1.8140 46.076	0.594 15.09	0.548 13.92	6100 27100	6950 31000
J-68-1630	2.1250 53.975	2.6255 66.688	0.938 23.83	0.883 22.43	12500 55500	18000 80500
J-78-2039	2.4375 61.913	3.0630 77.800	1.219 30.96	1.176 29.87	20700 92000	31000 138000
J-92-3246	2.8750 73.025	3.8755 98.438	1.438 36.53	1.373 34.87	34500 154000	46500 206000
J-104-2430	3.2500 82.550	4.0005 101.613	0.938 23.93	0.890 22.61	17200 76500	23400 104000
J-104-2442	3.2500 82.550	4.0005 101.613	1.313 33.35	1.243 31.57	24900 111000	37500 167000
J-108-2034	3.3750 85.725	4.0005 101.613	1.063 27.00	1.006 25.55	18100 80500	28500 127000
J-114-2039	3.5625 90.488	4.1880 106.375	1.219 30.96	1.176 29.87	25300 112000	45000 200000
J-120-2026	3.7500 95.250	4.3755 111.138	0.813 20.65	0.762 19.35	13500 60000	20300 90500
J-124-2442	3.8750 98.425	4.6255 117.488	1.313 33.35	1.248 31.70	27100 121000	44500 197000
J-128-2446	4.0000 101.600	4.7505 120.663	1.438 36.53	1.377 34.98	32000 143000	55500 248000
J-132-2030	4.1250 104.775	4.7505 120.663	0.938 22.83	0.881 22.38	16900 75500	28000 124000

* Special crown roller

Custom “R” Series

In addition to the standard and special cylindrical roller bearings described in previous pages of this catalog, NTN-Bower also manufactures a customized line of precision non-standard cylindrical roller bearings. This line of bearings was custom designed and manufactured to a customer requirement, or was recommended by NTN-Bower to improve the performance of an existing application.

Listed below and on the following pages is a part number listing and contains the basic bearing dimensions, and radial and static load ratings.

Since this product line is of a customized nature and contains many different bearing configurations, cage styles, etc., contact NTN Sales for additions information and part number availability.

Typical applications for this product line include:

- Automotive Rear Wheels
- Automotive and Truck Pinion Pilot
- Industrial Clutch Pilot Support
- Steel Mill Ingot Car Wheels
- Steel Mill Conveyor Wheels

Complete Bearing Number	Basic Bearing Dimensions			Roller Assembly Number	Basic Bearing Dimensions			Radial Load Ratings	
	Inside Diameter	Outside Diameter	Width		Inside Diameter	Outside Diameter	Width	Dynamic	Static
	Inch/mm				Inch/mm			lbs/N	
R-1500-EL	—	—	—	R-1500-EL	1.5800 40.132	2.4062 61.117	0.7500 19.050	10000 44500	12600 56000
RA-1502-EL	1.5308 38.882	2.7818 70.658	1.3440 34.138	R-1502-EL	1.8722 47.681	2.7818 70.658	0.8750 22.225	12200 54000	15800 70500
R-1506-EL	—	—	—	R-1506-EL	1.8287 46.449	3.1250 79.375	0.7480 19.000	11500 51500	11300 50000
R-1518-EL	—	—	—	R-1518-EL	0.8109 20.597	1.6535 41.999	0.5118 13.000	4250 18800	3400 15100
RR-1522-EHL	3.9370 100.000	8.4646 215.001	2.0472 51.999	R-1522-EHL	5.1323 130.360	8.4646 215.001	2.0472 51.999	87000 385000	108000 480000
RU-1523-CHV	7.8740 200.000	12.2047 310.000	2.0472 51.999	RU-1523-V	7.8740 200.000	11.0487 280.637	2.0079 51.001	123000 550000	206000 915000
RUB-1523-DV	8.2500 209.550	12.2047 310.000	2.0079 51.001	RUB-1523-V	8.2500 209.550	11.0487 280.637	2.0079 51.001	123000 550000	206000 915000
RA-1530-EL	3.1496 80.000	6.6929 170.000	1.7500 44.450	R-1530-EL	4.0041 101.704	6.6929 170.000	1.7500 44.450	64000 285000	77000 345000
RR-1530-EL	3.1496 80.000	6.6929 170.000	1.7500 44.450	R-1530-EL	4.0041 101.704	6.6929 170.000	1.7500 44.450	64000 285000	77000 345000
R-1535-TAV	—	—	—	R-1535-TAV	1.1092 28.174	1.8505 47.000	0.6560 16.662	6450 28700	6550 29100
RU-1540-CAL	3.9370 100.000	7.0894 180.071	1.4567 37.000	RU-1540-L	3.9370 100.000	6.3436 161.127	1.4567 37.000	54500 243000	71000 315000
RSN-1542-EBL	1.3776 34.991	3.0000 76.200	1.4687 37.306	—	—	—	—	9550 42500	9550 42500
RU-1545-SAXL	2.3622 59.995	5.1204 130.058	1.3125 33.338	RU-1545-L	2.3622 60.000	4.4264 112.431	1.3125 33.338	37500 167000	43000 192000
RU-1547-CAHL	3.5433 90.000	7.4833 190.076	1.8504 47.000	RU-1547-L	3.5433 90.000	6.5088 165.324	1.8504 47.000	72500 325000	86500 385000
RU-1547-DAHL	3.5433 90.000	7.4833 190.076	1.8504 47.000	RU-1547-L	3.5433 90.000	6.5088 165.324	1.8504 47.000	72500 325000	86500 385000
RU-1547-DHEL	3.5433 90.000	7.4833 190.076	1.8504 47.000	RU-1547-L	3.5433 90.000	6.5088 165.324	1.8504 47.000	72500 325000	86500 385000
RU-1549-L	—	—	—	RU-1549-L	1.1806 29.987	2.4397 61.968	0.6299 16.000	9050 40500	8850 39500
RU-1557-J	—	—	—	RU-1557-J	1.1806 29.987	2.4397 61.968	0.7500 19.050	12400 55000	12200 54000

“R” Series Dimensions and Load Ratings

Complete Bearing Number	Basic Bearing Dimensions			Roller Assembly Number	Basic Bearing Dimensions			Radial Load Ratings	
	Inside Diameter	Outside Diameter	Width		Inside Diameter	Outside Diameter	Width	Dynamic	Static
	Inch/mm				Inch/mm			lbs/N	
R-1558-TAV	—	—	—	R-1558-TAV	0.7515 19.088	1.2508 31.770	0.6050 15.367	3850 17100	3900 17200
R-1559-TAV	—	—	—	R-1559-TAV	1.6201 41.151	2.5312 64.292	0.8300 21.082	12700 56500	14800 65500
R-1559-TDV	—	—	—	R-1559-TDV	1.6210 41.173	2.5312 64.292	0.8300 21.082	12700 56500	14800 65500
RA-1562-EBL	1.1807 29.990	2.8356 72.024	1.1875 30.163	—	—	—	—	11100 49500	10800 48000
R-1563-TKV	—	—	—	R-1563-TKV	1.4008 35.580	2.2500 57.150	0.7000 17.780	8600 38500	9300 41500
RA-1567-EBF	1.3775 34.989	3.1506 80.025	1.3750 34.925	—	—	—	—	14000 62000	14300 63500
RA-1567-EBL	1.3775 34.989	3.1506 80.025	1.3750 34.925	—	—	—	—	14000 62000	14300 63500
RU-1570-UM	1.3776 34.991	2.8346 71.999	0.8130 20.650	—	—	—	—	14800 66000	16200 72000
RU-1570-UBM	1.3776 34.991	2.8646 72.761	0.8130 20.650	—	—	—	—	14800 66000	16200 72000
RUB-1570-UM	1.1811 30.000	2.8346 71.999	0.8130 20.650	—	—	—	—	14800 66000	16200 72000
RA-1572-EBL	1.7712 44.988	3.9384 100.035	1.5625 39.688	—	—	—	—	21800 97000	23600 105000
RSB-1578-EF	1.3780 35.001	2.5590 64.999	1.3700 34.798	—	—	—	—	8900 39500	9400 42000
RSB-1579-EF	1.5630 39.700	2.8760 73.050	1.3180 33.477	—	—	—	—	11200 50000	11700 52000
RSB-1579-EBF	1.5630 39.700	3.1493 79.992	1.3810 35.077	—	—	—	—	11200 50000	11700 52000
RSD-1579-EF	1.5630 39.700	2.8760 73.050	1.3810 33.477	—	—	—	—	11200 50000	11700 52000
RUB-1580-EBF	1.6248 41.275	3.1496 80.000	1.0830 27.508	—	—	—	—	10100 45000	9350 41500
RUB-1580-ECF	1.6248 41.275	3.1496 80.000	1.0830 27.508	—	—	—	—	10100 45000	9350 41500
R-1581-TV	1.2639 32.103	2.0472 51.999	0.7650 19.431	R-1581-TV	—	—	—	9300 41500	9950 44500
RSD-1584-EV	1.7717 45.001	3.1496 80.000	1.5294 38.847	—	—	—	—	14100 63000	15800 70000
RSN-1584-EF	1.7717 45.001	3.1496 80.000	1.5294 38.847	—	—	—	—	14100 63000	15800 70000
R-1722-TV	—	—	—	R-1722-TV	1.4026 35.626	2.2500 57.150	0.7000 17.780	8600 38500	9300 41500
RS-1930-EJ	5.9055 150.000	8.2677 210.000	1.1024 28.000	R-1930-EJ	5.9055 150.000	8.2677 210.000	1.1024 28.000	36500 163000	56500 251000
TW-2319	3.5635 90.513	10.0100 254.254	4.0100 101.854	—	—	—	—	111000 490000	151000 670000
TW-5216	2.7510 69.875	7.0100 178.054	3.1350 79.629	—	—	—	—	52500 235000	77500 345000

“R” Series Dimensions and Load Ratings

Complete Bearing Number	Basic Bearing Dimensions			Roller Assembly Number	Basic Bearing Dimensions			Radial Load Ratings	
	Inside Diameter	Outside Diameter	Width		Inside Diameter	Outside Diameter	Width	Dynamic	Static
	Inch/mm				Inch/mm			lbs/N	
TW-5217	3.2508 82.570	7.0100 178.054	3.1350 76.629	—	—	—	—	55000 244000	78500 350000
TWB-5217	3.2508 82.570	7.0100 178.054	3.1350 76.629	—	—	—	—	55000 244000	78500 350000
TWC-5217	3.2508 82.570	7.0100 178.054	3.1350 76.629	—	—	—	—	55000 244000	75800 350000
TW-5218	3.5010 88.925	7.0100 178.054	3.4375 84.313	—	—	—	—	65000 290000	94000 420000
RS-5305-W	1.2506 31.765	2.4419 62.024	1.0620 26.925	RS-5305-W	—	—	—	14900 66500	14900 66500
RBS-5305-W	0.9843 25.001	2.4419 62.024	1.0620 26.975	RBS-5305-W	—	—	—	14900 66500	14900 66500
TW-5309	1.7510 44.475	5.0100 127.254	2.8220 71.679	—	—	—	—	33500 148000	40500 181000
R-5707-EV	—	—	—	R-5707-EV	1.4018 35.606	2.2519 57.198	0.7050 17.907	9750 43500	9650 43000
R-5806-DF	—	—	—	R-5806-DF	1.1838 30.069	2.2835 58.001	0.8540 21.692	12200 54000	12100 54000
R-6207-CF	—	—	—	R-6207-CF	1.3780 35.000	2.4409 61.999	0.6693 17.000	7300 32500	6550 29100
R-6208-TBM	—	—	—	R-6208-TBM	1.5008 38.120	2.4409 61.999	1.4700 37.338	15100 67000	21200 94500
R-6208-TKM	—	—	—	R-6208-TKM	1.5008 38.120	2.007 61.999	1.4700 37.338	15100 67000	21200 94500
R-6208-TM	—	—	—	R-6208-TM	1.5008 38.120	2.4409 61.999	1.4700 37.338	15100 67000	21200 94500
R-6408-EV	—	—	—	R-6408-EV	1.6203 41.156	2.5304 64.272	0.8300 21.082	13300 59000	14000 62500
RU-6805-UM	1.0930 27.762	2.6772 68.000	0.7480 19.000	—	—	—	—	14200 63000	15100 67000
RU-6806-UM	1.0930 27.762	2.6772 68.000	0.7480 19.000	—	—	—	—	12300 55000	12600 56000
RU-8509-TM	1.7500 44.450	3.3465 85.001	1.1250 28.575	RU-8509-TM	—	—	—	14600 65000	17000 76000
RU-9008UM	1.5748 40.000	3.5433 90.000	0.9843 25.001	RU-9008UM	—	—	—	23000 102000	23500 104000
RU-9008UBM	1.5748 40.000	3.6224 92.009	0.9843 25.001	RU-9008UBM	—	—	—	23000 102000	23500 104000
RU-9808-UCM	1.5748 39.400	3.5433 89.000	0.9843 25.001	—	—	—	—	23000 102000	23500 104000
R-10012-GEXR	2.3030 58.496	3.3970 86.284	0.9843 25.001	R-10012-GEXR	—	—	—	22200 98500	23800 106000
R-16828-EX	—	—	—	R-16828-EX	5.5020 139.751	6.6250 168.275	1.0630 27.000	29300 131000	56500 252000
RAB-61539-EV	3.6120 91.745	6.6941 170.030	1.6562 42.067	R-61539-EV	4.3190 109.703	6.6941 170.030	1.5354 38.999	58500 260000	71500 320000
RU-61565-DV	7.0010 177.825	11.3750 288.925	2.8125 71.438	RU-61565-V	7.0010 177.825	10.4614 265.720	2.8125 71.438	163000 725000	255000 1140000
RU-61568-DV	8.2510 209.575	12.5000 317.500	2.8125 71.438	RU-61568-V	8.2510 209.575	11.6184 295.107	2.8125 71.438	172000 765000	284000 1260000

Mast and Chain Guide Bearings

Fork lift trucks are employed in almost every manufacturing and shipping facility where lifting or movement of materials is required. An essential part of a fork lift truck is the channeled lift structure which is commonly called the mast. Roller bearings are a basic part of the mast as they guide and retain the forks in the vertical channels. Chain sheave roller bearings which guide the chain and facilitate the lifting and lowering of the mast are an important part of the entire upright system.

Fork lift trucks handle loads ranging from light, bulky material to heavy loads in excess of 4,000 pounds. Mast guide bearings are specifically designed to withstand the heavy impact and radial loads required in this type of application. Mast or chain guide bearings have heavy section outer rings which serve as rollers, or guides for the carriage in the mast channels. The configuration of the outer ring is designed to fit the contour of the mast channel or chain.

In conjunction with the heavy radial loads experienced, thrust loading is also present, which tends to cause misalignment. The internal construction of NTN-Bower cylindrical roller bearings resists misalignment of the outer ring. All mast guide and chain sheave roller bearings are sealed and factory lubricated with a water resistant grease to prevent contamination of the rolling elements and raceways.

NTN-Bower cylindrical roller bearings for mast and chain guide applications are manufactured for leading fork lift truck manufacturers. They are basic full roller complement (no cage) 1200 and 1300 series bearings of single row construction.

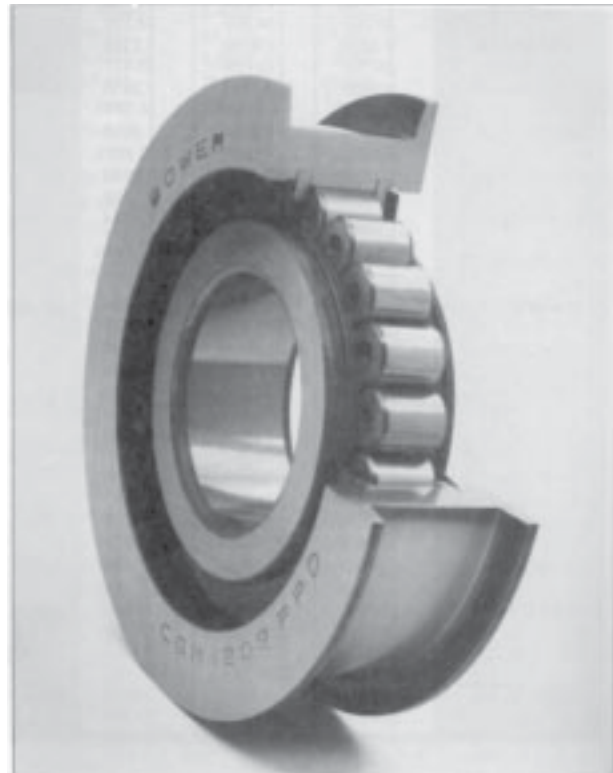
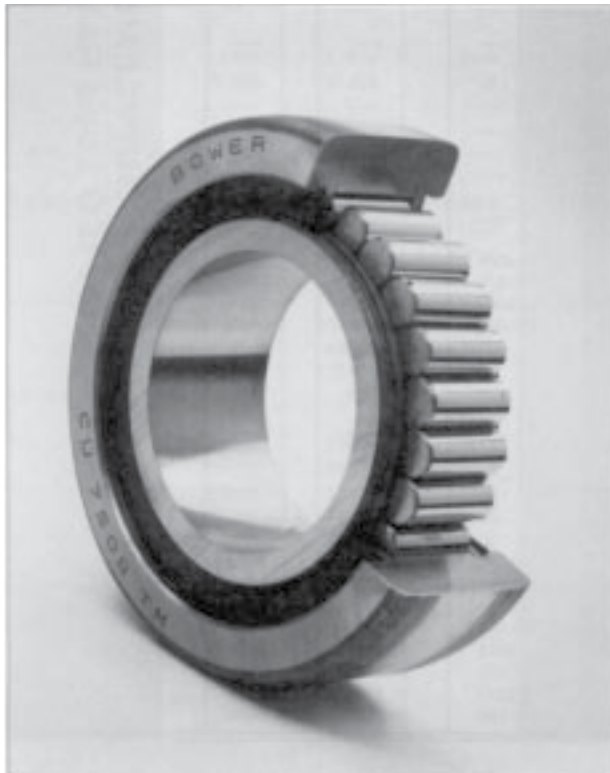

Mast and Chain Guide Bearings Dimensions and Load Ratings

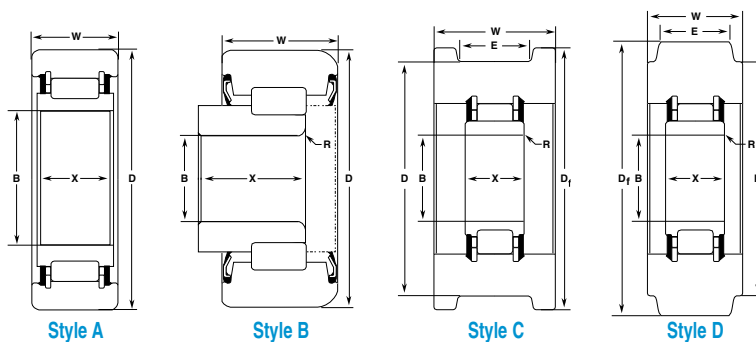

Bearing Number	Style	B	D	X	W	R	E	D _f	Radial Load Ratings	
		Inside Diameter	Outside Diameter	Race Width		Break	Sheave		Dynamic	Static
		Inch/mm								lbs/N
▲ CGM-1209-PPA	C	1.5748 40.000	3.755 95.38	0.905 22.99	1.307 33.20	.070 R 1.78	0.995 25.27	4.250 107.95	14200 63000	16100 71500
CGM-1209-PPB	C	1.5748 40.000	3.740 95.00	1.140 28.96	1.025 26.04	.070 R 1.78	0.730 18.54	4.252 108.00	14200 63000	16100 71500
■ CGM-1209-PPC	C	1.5748 40.000	3.230 82.04	1.005 25.53	1.025 26.04	.070 R 1.78	0.730 18.54	3.740 95.00	14200 63000	16100 71500
▲ CGM-1209-PPD	C	1.5748 40.000	3.505 89.03	0.905 22.99	1.125 28.58	.070 R 1.78	0.870 22.10	4.000 101.60	14200 63000	16100 71500
▲ CGM-1209-PPE	C	1.5748 40.000	3.755 95.38	0.905 22.99	1.347 34.21	0.07R 1.78	1.065 27.05	4.125 104.77	14200 63000	16100 71500
CGM-5207-PPA	C	1.3780 35.000	3.583 91.00	1.187 30.15	1.949 49.50	.118x45° C 3.00	1.646 41.81	4.055 103.00	17800 79500	21400 95500
CGM-5207-PPB	C	1.3780 35.000	3.583 91.00	1.187 30.15	1.949 49.50	.118x45° C 3.00	1.394 35.41	4.055 103.0	17800 79500	21400 95500
CGM-5214-PPB	C	1.7717 45.000	5.040 128.00	2.000 50.80	2.717 69.00	.394 R 10.00	1.968 50.00	5.920 150.37	39000 172000	50500 225000
CGM-5214-PPD	C	1.7717 45.000	5.906 150.00	2.000 50.80	2.835 72.00	0.394R 10.00	1.968 50.00	6.890 175.00	39000 172000	50500 225000
CGM-5216-PPA	C	1.9685 50.000	5.000 127.00	1.574 39.98	2.087 53.00	.110 R 2.79	1.417 36.00	5.906 150.00	43500 193000	55500 248000
■ CS-5704-EM	B	0.7500 19.050	2.250 57.15	0.963 24.46	0.995 25.27	.070 R 1.78	— —	— —	9000 40000	10100 45000
● CU-7508-TM	A	1.5739 39.977	2.295 75.57	0.875 22.23	1.000 25.40	.015x45° C 0.38	— —	— —	13300 59000	18900 84000
CU-8907-TM	C	1.3780 35.000	3.500 88.90	1.062 26.97	1.625 41.28	.040 R 1.02	1.280 32.51	4.000 101.60	19100 85000	21000 93500
CGM-9509-PPA	C	1.7500 44.450	3.723 94.56	1.573 39.95	1.750 44.45	0.070 1.78	1.373 34.87	4.375 111.13	28600 127000	34500 154000
CU-10009-UV	A	1.7712 44.988	3.937 100.00	1.563 39.70	1.563 39.70	0.110R 2.79	— —	— —	26300 117000	30000 134000
CU-10308TM	D	1.5748 39.100	4.055 102.10	0.906 23.01	0.906 23.01	0.090 2.29	0.575 14.61	3.493 88.72	16000 71000	18000 80000
CU-10807-TM	C	1.3780 35.000	4.250 107.95	1.062 26.97	1.625 41.28	.040 R 1.02	1.280 32.51	4.750 120.65	19100 85000	21000 93500
CU-15010-TM	A	1.9685 49.100	5.905 149.99	1.575 40.01	2.087 53.01	0.110 2.79	— —	— —	43500 193000	55500 248000

- ▲ Two 1/8 inch diameter holes in inner ring, 180° apart.
- Inner ring not central to outer ring.
- Spherical O.D.
- ◆ Dynamic radial load ratings are based on 500 hrs. L10 Life @ 33 1/3 rpm.

ABMA/ANSI Dimensional Tolerances Inner Ring

Basic Bore Diameter		Bore Diameter Tolerances*					Radial Runout	Width Limits	
		B Mean		Out of Roundness					
				Diameter Series					
				900	000	200 300			
Inch/mm		.0001 Inch/Micrometres							
Over	Incl.	High	Low	Max.	Max.	Max.	Max.	High	Low
0.7087 18.000	1.1811 30.000	+ 0 + 0	-4 -10	5 13	4 10	3 8	5 13	+ 0 + 0	-47 -120
1.1811 30.000	1.9685 50.000	+ 0 + 0	-4.5 -12	6 15	4.5 12	3.5 9	6 15	+ 0 + 0	-47 -120
1.9685 50.000	3.1496 80.000	+ 0 + 0	-6 -15	7.5 19	7.5 19	4.5 11	8 20	+ 0 + 0	-59 -150
3.1496 80.000	4.7244 120.000	+ 0 + 0	-8 -20	10 25	10 25	6 15	10 25	+ 0 + 0	-79 -200
4.7244 120.000	7.0866 180.000	+ 0 + 0	-10 -25	12 31	12 31	7.5 19	12 30	+ 0 + 0	-98 -250
7.0866 180.000	9.8425 250.000	+ 0 + 0	-12 -30	15 38	15 38	9 23	16 40	+ 0 + 0	-118 -300
9.8425 250.000	12.4015 315.000	+ 0 + 0	-14 -35	17 44	17 44	10 26	20 50	+ 0 + 0	-138 -350
12.4015 315.000	15.7480 400.000	+ 0 + 0	-16 -40	20 50	20 50	12 30	24 60	+ 0 + 0	-157 -400

* B Mean represents the Mean Bore Diameter Tolerance.
Out of Roundness represents the Maximum Bore Diameter Variation in a single radial plane.

Outer Ring

Basic Outside Diameter		Outside Diameter Tolerances**					Radial Runout	Width Limits	
		D Mean		Out of Roundness					
				Open Bearing		Bearing With Internal Snap Rings			
				Diameter Series					
900	000	200/300	200/300						
Inch/mm		.0001 Inch/Micrometres							
Over	Incl.	High	Low	Max.	Max.	Max.	Max.	Max.	High/Low
1.1811 30.000	1.9685 50.000	+0 +0	-4.5 -11	5.5 14	4.5 11	3 8	6.5 16	8 20	Same as Inner Ring of the Same Bearing
1.9685 50.000	3.1496 80.000	+0 +0	-5 -13	6.5 16	5 13	4 10	8 20	10 25	
3.1496 80.000	4.7244 120.000	+0 +0	-6 -15	7.5 19	7.5 19	4.5 11	10 26	14 35	
4.7244 120.000	5.9055 150.000	+0 +0	-7 -18	9 23	9 23	5.5 14	12 30	16 40	
5.9055 150.000	7.0866 180.000	+0 +0	-10 -25	12 31	12 31	7.5 19	15 38	18 45	
7.0866 180.000	9.8425 250.000	+0 +0	-12 -30	15 38	15 38	9 23	— —	20 50	
9.8425 250.000	12.4015 315.000	+0 +0	-14 -35	17 44	17 44	10 26	— —	24 60	
12.4015 315.000	15.7480 400.000	+0 +0	-16 -40	20 50	20 50	12 30	— —	28 70	
15.7480 400.000	19.6850 500.000	+0 +0	-18 -45	22 56	22 56	13 34	— —	31 80	

** D Mean represents the Mean Outside Diameter Tolerance.
Out of Roundness represents the Maximum Outside Diameter Variation in a single radial plane.

Outer Ring Dowel Holes

Rotational or lateral movement of an outer ring can be prevented by doweling the ring in the housing. This method of mounting is used with either loosely fitted or heavily fitted rings as a precautionary measure. It is important that the blind dowel hole in the ring be located outside the load zone of the bearing.

The dowel holes are located centrally in the width of the outer ring and are identified by a letter "H" in the suffix of the bearing part number. Example: MR1310EHL. The dowel hole dimensions for each bearing size are charted below.

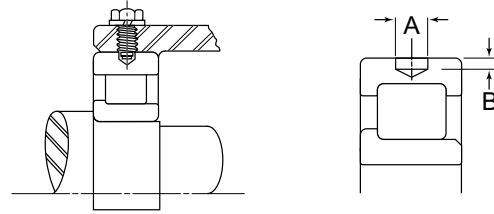

Basic Bearing Number									A	B		
'M' Series				'W' Series					Hole Diameter	Hole Depth		
1900	1000	1200 5200	1300 7300 5300	61900	61000	61200	67200	61300 67300		Inch/mm		
									Nominal	Maximum	Minimum	
911 THRU 916	007 THRU 010	205 THRU 206	304 THRU 305	911 THRU 920	007 THRU 011	205 THRU 207			0.281 7.14	0.600 1.52	0.040 1.02	
917 THRU 924	011 THRU 017	207 THRU 210		921 THRU 924	012 THRU 017	208 THRU 210			0.281 7.14	0.080 2.03	0.060 1.52	
					018 THRU 021	211	207 THRU 211		0.312 7.92	0.08 2.03	0.060 1.52	
926 THRU 928	018 THRU 021	211 THRU 215	306 THRU 309	925 THRU 228		212 THRU 216			0.312 7.92	0.110 2.79	0.090 2.29	
				930 THRU 934	022 THRU 024				0.375 9.52	0.110 2.79	0.090 2.29	
930 THRU 938	022 THRU 028	216 THRU 217	310 THRU 313	936 THRU 948	026 THRU 028				0.375 9.52	0.140 3.56	0.120 3.05	
							212 THRU 216	312 THRU 313	0.438 11.13	0.110 2.79	0.090 2.29	
						217 THRU 218	217 THRU 218		0.438 11.13	0.140 3.56	0.120 3.05	
940 THRU 964	030 THRU 064	218 THRU 228	314 THRU 321	952 THRU 964	030 THRU 064	219 THRU 232	219 THRU 232	314 THRU 320	0.438 11.13	0.180 4.57	0.160 4.06	
	230 THRU 264	322 THRU 340							0.500 12.7	0.210 5.33	0.180 4.57	
						234 THRU 264	234 THRU 264		0.500 12.7	0.210 5.33	0.190 4.83	

Outer Ring Groove & Snap Ring Dimensions

Outer rings can be retained axially in the housing bore by use of snap rings.

The groove and snap ring are identified by the letters G & R in the suffix of the bearing part number.

The groove without the snap ring is sometimes used as a puller groove to facilitate servicing.

Example: MU1310GCLR (Groove with snap ring)
MU1310GCL (Groove only)

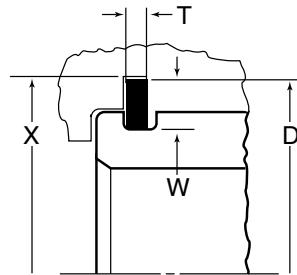
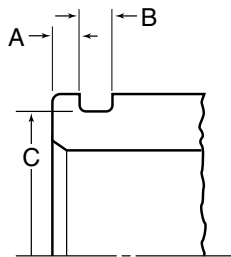

Series Number			A (Groove Location)		B	C		D	T	W	X
			1000-1900	1200-1300 5200-7300-5300	Groove Width	Groove Diameter		Snap Ring Diameter	Snap Ring Thickness	Snap Ring Height	Counter Bore
1000 1900	1200 5200	1300 7300 5300	Inch/mm								
			Nominal	Nominal	Nominal	Maximum	Tolerance	Nominal	Nominal	Nominal	Minimum
	1204			0.094 2.39	0.056 1.42	1.756 44.60	-0.010 -0.25	2.062 52.37	0.042 1.07	0.156 3.96	2.094 53.19
	1205	1304		0.094 2.39	0.056 1.42	1.958 49.73	-0.010 -0.25	2.266 57.56	0.042 1.07	0.156 3.96	2.297 59.34
1006			0.078 1.98		0.056 1.42	2.071 52.60	-0.010 -0.25	2.375 60.32	0.042 1.07	0.156 3.96	2.406 61.11
1007	1206	1305	0.078 1.98	0.125 3.18	0.078 1.98	2.347 59.61	-0.020 -0.51	2.656 67.46	0.065 1.65	0.156 3.96	2.688 68.28
1008			0.094 2.39		0.078 1.98	2.552 64.82	-0.020 -0.51	2.922 74.22	0.065 1.65	0.188 4.78	2.984 75.79
	1207	1306		0.125 3.18	0.078 1.98	2.709 68.81	-0.020 -0.51	3.078 78.18	0.065 1.65	0.188 4.78	3.141 79.78
1009			0.094 2.39		0.078 1.98	2.828 71.83	-0.020 -0.51	3.203 81.36	0.065 1.65	0.188 4.78	3.266 82.96
1010	1208	1307	0.094 2.39	0.125 3.18	0.078 1.98	3.024 76.81	-0.020 -0.51	3.406 86.51	0.065 1.65	0.188 4.78	3.469 88.11
1911			0.078 1.98		0.056 1.42	3.066 77.88	-0.020 -0.41	3.312 84.12	0.042 1.07	0.125 3.18	3.375 85.72
	1209			0.125 3.18	0.078 1.98	3.221 81.81	-0.020 -0.51	3.594 91.29	0.065 1.65	0.188 4.78	3.656 92.86
1912			0.078 1.98		0.056 1.42	3.263 82.88	-0.020 -0.41	3.516 89.31	0.042 1.07	0.125 3.18	3.578 90.88
1011	1210	1308	0.109 2.77	0.125 3.18	0.109 2.77	3.417 86.79	-0.020 -0.51	3.797 96.44	0.095 2.41	0.188 4.78	3.859 98.02
1913			0.078 1.98		0.056 1.42	3.459 87.86	-0.020 -0.41	3.703 94.06	0.042 1.07	0.125 3.18	3.766 95.66
1012			0.109 2.77		0.109 2.77	3.615 91.82	-0.020 -0.51	3.984 101.19	0.095 2.41	0.188 4.78	4.047 102.79
1013	1211	1309	0.109 2.77	0.125 3.18	0.109 2.77	3.811 96.80	-0.020 -0.41	4.188 106.38	0.095 2.41	0.188 4.78	4.250 107.95
1914			0.094 2.39		0.056 1.42	3.853 97.87	-0.020 -0.51	4.109 104.37	0.042 1.07	0.125 3.18	4.172 105.97

Outer Ring Groove & Snap Ring Dimensions

Series Number			A (Groove Location)		B	C		D	T	W	X
			1000-1900	1200-1300 5200-7300-5300	Groove Width	Groove Diameter		Snap Ring Diameter	Snap Ring Thickness	Snap Ring Height	Counter Bore
1000 1900	1200 5200	1300 7300 5300	Inch/mm								
			Nominal	Nominal	Nominal	Maximum	Tolerance	Nominal	Nominal	Nominal	Minimum
1915			0.094 2.39		0.056 1.42	4.040 102.62	-0.020 -0.51	4.359 110.72	0.042 1.07	0.156 3.96	4.422 112.32
1014	1212	1310	0.109 2.77	0.125 3.18	0.109 2.77	4.205 106.81	-0.020 -0.51	4.578 116.28	0.095 2.41	0.188 4.78	4.641 117.88
1916			0.094 2.39		0.056 1.42	4.237 107.62	-0.020 -0.51	4.457 115.49	0.042 1.07	0.156 3.96	4.609 117.07
1015			0.109 2.77		0.109 2.77	4.402 118.81	-0.020 -0.51	4.781 121.44	0.095 2.41	0.188 4.78	4.844 123.04
	1213	1311		0.156 3.96	0.125 3.18	4.536 115.21	-0.020 -0.51	5.094 129.39	0.109 2.77	0.281 7.14	5.156 130.96
1917			0.125 3.18		0.056 1.42	4.630 117.60	-0.020 -0.51	4.938 125.43	0.042 1.07	0.156 3.96	5.000 127.00
1016	1214		0.109 2.77	0.156 3.96	0.125 3.18	4.733 120.22	-0.020 -0.51	5.297 134.54	0.109 2.77	0.281 7.14	5.359 136.12
1918			0.125 3.18		0.056 1.42	4.827 122.61	-0.020 -0.51	5.141 130.58	0.042 1.07	0.156 3.96	5.203 132.16
1017	1215	1312	0.109 2.77	0.156 3.96	0.125 3.18	4.930 125.22	-0.020 -0.51	5.500 139.70	0.109 2.77	0.281 7.14	5.562 141.27
1919			0.125 3.18		0.056 1.42	5.024 127.61	-0.020 -0.51	5.328 135.33	0.042 1.07	0.156 3.96	5.391 136.93
1018	1216	1313	0.141 3.58	0.188 4.78	0.125 3.18	5.324 135.23	-0.020 -0.51	5.891 149.63	0.109 2.77	0.281 7.14	5.953 151.21
1920			0.125 3.18		0.078 1.98	5.418 137.62	-0.020 -0.51	5.734 145.64	0.065 1.65	0.156 3.96	5.797 147.24
1019			0.141 3.58		0.125 3.18	5.521 140.23	-0.020 -0.51	6.078 154.38	0.109 2.77	0.281 7.14	6.141 155.98
1921			0.125 3.18		0.078 1.98	5.615 142.62	-0.020 -0.51	5.922 150.42	0.065 1.65	0.156 3.96	5.984 151.99
1020	1217	1314	0.141 3.58	0.188 4.78	0.125 3.18	5.718 145.24	-0.020 -0.51	6.281 159.54	0.109 2.77	0.281 7.14	6.344 161.14
1922			0.125 3.18		0.078 1.98	5.812 147.62	-0.020 -0.51	6.125 155.58	0.065 1.65	0.156 3.96	6.188 157.18
1021	1218	1315	0.141 3.58	0.188 4.78	0.125 3.18	6.111 155.22	-0.020 -0.51	6.672 169.47	0.109 2.77	0.281 7.14	6.734 171.04
1924			0.141 3.58		0.078 1.98	6.371 161.82	-0.020 -0.51	6.750 171.45	0.065 1.65	0.188 4.78	6.812 173.02
1022	1219	1316	0.141 3.58	0.219 5.56	0.141 3.58	6.443 163.65	-0.020 -0.51	7.188 182.58	0.120 3.05	0.375 9.52	7.250 184.15

Internal Diametral Clearance

The internal diametral clearance for cylindrical roller bearings listed in this catalog are given on the following tables. Unlike ISO cylindrical and ball bearings whose diametral clearance follows ABMA/ANSI guidelines, Bower cylindricals are manufactured to a set clearance range. This range is designed to result in the optimal mounted clearance condition when using recommended Bower fitting practices as outlined in this catalog.

Special clearance ranges that fall outside those listed on the following tables can be manufactured on request. The part number for the bearing will reflect this special clearance range with a “CB” suffix followed the mean clearance condition in .0001 inches.

For example, MU1208UMCB40 would have a mean clearance value of .0040 inches, whereas the standard clearance condition is .00215 inches.

Internal Diametral Clearance For Standard "M" Series Cylindrical Roller Bearings

Bore Desig.	Basic "M" Series Radial Clearance — .0001 Inches/Micrometers																Bore Desig.
	-900 Standard		-900 "A" Style		-000 Standard		-000 "A" Style		-200 Standard		-200 "A" Style		-300 Standard		-300 "A" Style		
	Min	Max	Min	Max	Min	Max	Min	Max	Min	Max	Min	Max	Min	Max	Min	Max	
00					9	17	18	26	9	17	17	25	9	17	18	26	00
					23	43	46	66	23	43	43	64	23	43	46	66	
01					10	18	18	26	10	18	19	27	10	18	19	27	01
					25	46	46	66	25	46	48	69	25	46	48	69	
02					11	19	20	28	11	19	20	28	10	18	19	27	02
					28	48	51	71	28	48	51	71	25	46	48	69	
03					11	19	20	28	11	19	21	28	10	18	19	27	03
					28	48	51	71	28	48	51	71	25	46	48	69	
04	13	21	22	30	13	21	22	30	12	23	21	32	12	23	21	32	04
	33	53	56	76	33	53	56	76	30	58	53	81	30	58	53	81	
05	14	25	23	34	14	25	23	34	13	24	22	33	13	24	23	34	05
	36	64	58	86	36	64	58	86	33	61	56	84	33	61	58	86	
06	15	26	23	34	14	25	24	35	14	25	24	35	13	24	24	35	06
	38	66	58	86	36	64	61	89	36	64	61	89	33	61	61	89	
07	17	28	26	37	16	27	27	38	16	27	27	38	15	26	27	38	07
	43	71	66	94	41	69	69	97	41	69	69	97	38	66	69	97	
08	17	28	27	38	17	28	28	39	16	27	28	39	16	27	30	41	08
	43	71	69	97	43	71	71	99	41	69	71	99	41	69	76	104	
09	19	30	30	41	19	31	31	43	19	31	32	44	18	30	33	45	09
	48	76	76	104	48	79	79	109	48	79	81	112	46	76	84	114	
10	20	32	31	43	20	32	31	43	20	32	33	45	19	31	36	48	10
	51	81	79	109	51	81	79	109	51	81	84	114	49	79	91	122	
11	23	35	35	47	23	35	36	48	22	34	37	49	21	33	39	51	11
	58	89	89	119	58	89	91	122	56	86	94	124	53	84	99	130	
12	24	36	37	49	23	35	37	49	23	35	40	52	22	35	41	54	12
	61	91	94	124	58	89	94	124	58	89	102	132	56	89	104	137	
13	25	37	38	50	24	37	39	52	23	36	40	53	23	36	41	54	13
	64	94	97	127	61	94	99	132	58	91	102	135	58	91	104	137	
14	28	41	42	55	27	40	44	57	27	40	45	58	24	39	46	59	14
	71	104	107	140	69	102	112	145	69	102	114	147	66	99	117	150	
15	28	41	43	56	28	41	45	58	28	41	46	59	26	42	48	64	15
	71	104	109	142	71	104	114	147	71	104	117	150	66	107	122	163	
16	29	42	46	59	29	42	47	60	28	43	46	61	27	43	48	64	16
	74	107	117	150	74	107	119	152	71	109	117	155	69	109	122	163	
17	34	49	52	67	35	51	50	66	33	49	54	70	32	48	53	69	17
	86	124	132	170	89	130	127	168	84	124	137	178	81	122	135	175	
18	36	52	54	70	35	51	53	69	34	50	56	72	33	53	56	76	18
	91	132	137	178	89	130	135	175	86	127	142	183	84	135	142	193	

Internal Diametral Clearance For Standard "M" Series Cylindrical Roller Bearings (Cont'd)

Bore Desig.	Basic "M" Series Radial Clearance — .0001 Inches/Micrometers																Bore Desig.
	-900 Standard		-900 "A" Style		-000 Standard		-000 "A" Style		-200 Standard		-200 "A" Style		-300 Standard		-300 "A" Style		
	Min	Max	Min	Max	Min	Max	Min	Max	Min	Max	Min	Max	Min	Max	Min	Max	
19	36 91	52 132	54 137	70 178	36 91	52 132	56 142	73 183	34 86	50 127	56 142	72 183	33 84	53 135	57 145	77 196	19
20	37 94	53 135	55 140	71 180	36 91	52 132	56 142	72 183	35 89	53 135	56 142	74 188	34 86	55 140	59 150	80 203	20
21	37 94	55 140	58 147	76 193	37 94	55 140	58 147	76 193	36 91	55 140	59 150	78 198	34 86	55 140	61 155	82 208	21
22	38 97	56 142	58 147	76 193	37 94	56 142	59 150	78 198	36 91	55 140	60 152	79 201	34 86	55 140	63 160	84 213	22
24	39 99	58 147	61 155	80 203	38 94	57 145	60 152	79 201	37 94	56 142	63 160	82 208	36 91	58 147	66 168	88 224	24
26	45 114	64 163	66 168	85 216	44 112	63 160	68 173	87 221	43 109	63 150	70 178	90 229	41 104	63 160	71 180	93 236	26
28	47 119	67 170	70 178	90 229	46 117	68 173	70 178	92 234	44 112	66 168	73 185	95 241	42 107	68 173	75 191	101 257	28
30	53 135	75 191	78 198	100 254	53 135	75 191	79 201	101 257	50 127	72 183	80 203	102 259	49 124	76 193	84 213	111 282	30
32	55 140	77 196	81 206	103 262	54 137	76 193	83 211	105 267	52 132	75 191	84 213	107 272	50 127	77 196	85 216	112 284	32
34	57 145	80 203	84 213	109 272	55 140	78 198	85 216	108 284	53 135	76 193	86 218	109 277	52 132	79 201	88 224	115 292	34
36	58 147	81 206	86 218	109 277	57 145	80 203	86 218	109 277	55 140	80 203	90 229	115 292	53 135	81 206	89 226	117 297	36
38	65 165	88 224	95 241	118 300	64 163	89 226	96 244	121 307	61 155	87 221	97 246	123 312	59 150	87 221	96 244	124 315	38
40	67 170	93 236	97 246	123 312	65 165	91 231	98 249	124 315	63 160	91 231	99 251	127 323	62 157	91 231	101 257	130 330	40
44	70 178	96 244	103 262	129 328	68 173	94 239	104 264	130 330	66 168	95 241	103 262	132 335					44
48	74 188	101 257	109 277	136 345	72 183	99 251	108 274	135 343	71 180	100 254	109 277	138 351					48
52	80 203	107 272	117 297	144 366	79 201	108 274	115 292	144 366	77 196	107 272	116 295	146 371					52
56	84 213	114 290	120 305	150 381	84 213	114 290	122 310	152 386	81 206	111 282	120 305	150 381					56
60	88 224	118 300	124 320	156 396	87 221	117 297	126 320	156 396	84 213	115 292	126 320	157 399					60
64	97 249	128 325	136 345	166 422	97 246	128 325	136 345	167 424	93 236	124 315	135 343	166 422					64

Internal Diametral Clearance For Max-Pak "W" Series Cylindrical Roller Bearings

Bore Desig.	Max-Pak "W" Series Radial Clearance — .0001 Inches/Micrometers																Bore Desig.		
	6-900 Standard		6-900 "A" Style		6-000 Standard		6-000 "A" Style		6-200 Standard		6-200 "A" Style		6-300 Standard		6-300 "A" Style				
	Min	Max	Min	Max	Min	Max	Min	Max	Min	Max	Min	Max	Min	Max	Min	Max			
00														11	19	18	26	00	
														28	48	46	66		
01														11	19	18	26	01	
														28	48	46	66		
02														11	19	18	26	02	
														28	48	46	66		
03														12	20	19	27	03	
														30	51	48	69		
04									15	25			22	32	14	25	21	32	04
									38	64			56	81	36	64	53	81	
05									15	26			22	33	14	25	23	34	05
									38	66			56	84	36	64	58	86	
06					16	27	23	34	15	26	24	35	14	25	24	35			06
					41	69	58	86	38	66	61	89	36	64	61	89			
07					18	29	27	38	17	28	27	38	17	28	27	38			07
					46	74	69	97	43	71	69	97	43	71	69	97			
08					19	30	28	39	18	29	28	39	18	29	29	40			08
					48	76	71	99	46	74	71	99	46	74	74	102			
09					22	33	31	42	22	34	32	44	21	33	33	45			09
					56	84	79	107	56	86	81	112	53	84	84	114			
10					22	34	32	44	22	34	34	46	21	33	37	49			10
					56	86	81	112	56	86	86	117	53	84	94	124			
11	26	38	36	48	26	38	37	49	25	37	38	50	24	36	39	51			11
	66	97	91	122	66	97	94	124	64	94	97	127	61	91	99	130			
12	27	39	37	49	26	38	38	50	25	37	41	53	25	38	42	55			12
	69	99	94	124	66	97	97	127	64	94	104	135	64	97	107	140			
13	28	40	39	51	27	39	40	52	26	39	41	54	26	39	42	55			13
	71	102	99	130	69	99	102	132	66	99	104	137	66	99	107	140			
14	33	46	46	59	33	46	48	61	32	45	48	61	31	44	49	62			14
	84	117	117	150	84	117	122	155	81	114	122	155	79	112	124	157			
15	34	47	47	60	33	46	49	62	33	46	49	62	31	46	51	66			15
	86	119	119	152	84	117	124	157	84	117	124	157	79	117	130	168			
16	34	47	50	63	34	47	50	63	33	48	49	64	32	52	51	71			16
	86	119	127	160	86	119	127	160	84	122	124	163	81	132	130	180			
17	40	53	56	69	41	54	57	70	39	55	57	73	37	57	57	77			17
	102	135	142	175	104	137	145	178	99	140	145	185	94	145	145	196			
18	42	56	58	72	41	57	57	73	40	56	59	75	38	58	59	79			18
	107	142	147	183	104	145	145	185	102	142	150	191	97	147	150	201			

Internal Diametral Clearance For Max-Pak "W" Series Cylindrical Roller Bearings (Cont'd)

Bore Desig.	Max-Pak "W" Series Radial Clearance — .0001 Inches/Micrometers																Bore Desig.
	6-900 Standard		6-900 "A" Style		6-000 Standard		6-000 "A" Style		6-200 Standard		6-200 "A" Style		6-300 Standard		6-300 "A" Style		
	Min	Max	Min	Max	Min	Max	Min	Max	Min	Max	Min	Max	Min	Max	Min	Max	
19	42	56	59	73	41	57	60	76	40	56	60	76	39	59	61	81	19
	107	142	150	185	104	145	152	193	102	142	152	193	99	150	155	206	
20	42	58	59	75	42	58	60	76	41	57	60	76	39	60	63	84	20
	107	147	150	191	107	147	152	193	104	145	152	193	99	152	160	213	
21	43	59	62	78	43	59	63	79	41	58	63	80	40	61	65	86	21
	109	150	157	198	109	150	160	201	104	147	160	203	102	155	165	218	
22	44	60	62	78	43	59	63	79	42	63	64	85	39	60	66	87	22
	112	152	157	198	109	150	160	201	107	160	163	216	99	152	168	221	
24	45	62	64	81	44	61	64	81	43	64	67	88	40	66	68	94	24
	114	157	163	206	112	155	163	206	109	163	170	224	102	168	173	239	
26	51	68	70	87	50	71	72	93	48	70	73	95	45	71	73	99	26
	130	173	178	221	127	180	183	236	122	178	185	241	114	180	185	251	
28	53	70	74	91	52	74	75	97	50	72	76	98	48	74	79	105	28
	135	178	188	231	132	188	191	246	127	183	193	249	122	188	201	267	
30	60	82	83	105	59	81	84	106	56	78	84	106	54	81	88	115	30
	152	208	211	267	150	206	213	269	142	198	213	269	137	206	224	292	
32	62	84	86	108	61	83	87	109	57	80	87	110	55	85	89	116	32
	157	213	218	274	155	211	221	277	145	203	221	279	140	208	226	295	
34	64	86	89	111	64	84	90	113	59	82	90	113	57	84	91	118	34
	163	218	226	282	155	213	229	287	150	208	229	287	145	213	231	300	
36	65	88	91	114	63	86	91	114	60	83	94	117	58	86	93	121	36
	165	224	231	290	160	218	231	290	152	211	239	297	147	218	236	307	
38	75	98	103	126	73	96	103	126	70	98	104	132	67	95	102	130	38
	191	249	262	320	185	244	262	320	178	249	264	335	170	241	259	330	
40	76	99	104	127	75	99	106	130	72	100	106	134	72	100	108	136	40
	193	251	264	323	191	251	269	330	183	254	269	340	183	254	274	345	
44	80	104	111	135	78	102	112	136	74	103	109	138					44
	203	264	282	343	198	259	284	345	188	262	277	351					
48	83	108	117	142	82	107	116	141	79	108	116	145					48
	211	274	297	361	208	272	295	358	201	274	295	368					
52	93	124	127	158	91	120	125	154	89	119	126	156					52
	236	315	323	401	231	305	318	391	226	302	320	396					
56	96	127	131	162	97	127	133	163	92	122	129	159					56
	244	323	333	411	246	323	338	414	234	310	328	404					
60	101	133	137	169	98	128	135	165	95	126	134	165					60
	257	338	348	429	249	325	343	419	241	320	340	419					
64	117	149	153	185	115	146	152	183	109	140	149	180					64
	297	378	389	470	292	371	386	465	277	356	378	457					

General Fitting Practice

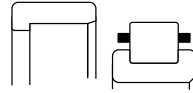

Separable Bearings

Shaft	Inner Ring Fit	Page	Outer Ring Fit	Page
Rotating	Press	91-92	Tap	97-98
Stationary	Tap	93-94	Press	99-100



MU----TV, MU----UV, MU----TM, MU----UM

Non-Separable Bearings

Shaft	Inner Ring Fit	Page	Outer Ring Fit	Page
Rotating	Press	91-92	Push	95-96

* "A" Style Fitting Practice

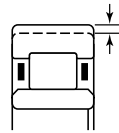

Identified by suffix letter "A" in part number

Over Size O.D.

Shaft	Inner Ring Fit	Page	Outer Ring Fit	Page
Rotating or Stationary	Press	91-92	Heavy Press*	101-102

Inner or Outer Ring Omitted



M----EL, M----TV

Inner Ring Omitted

Shaft	Inner Ring Fit	Page	Outer Ring Fit	Page
Rotating	Shaft Dia.	103	Tap/Heavy Press*	97-98/101-102
Stationary	Shaft Dia.	109	Press	91-92

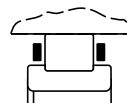

MU----L, MU----V

Outer Ring Omitted

Shaft	Inner Ring Fit	Page	Outer Ring Fit	Page
Rotating	Press	91-92	Housing Bore	106
Stationary	Tap	93-94	Housing Bore	105

* Over size outer ring for heavy press fit in standard (tap fit) size housing bore.

NOTE: The NTN Engineering Department should be consulted for any modification of the above fitting practice.

Fitting Practice

The fitting practice given in the following tables conforms to industry and ABMA/ANSI standards, where applicable. The tables provide maximum and minimum sizes for bearing bore and O.D., shaft and housing bore, and the resultant effects of each type of fit.

Dimensions are given in both inch and metric units with deviations in .0001 inch and micrometers.

The looseness or tightness of a ring mounted on a shaft or in a housing bore depends on the conditions under which the bearing will operate and how it will be installed. The three most generally used fits are: PRESS, TAP AND PUSH.

PRESS fit is used to fit a ring tightly to a rotating member (shaft or housing) to prevent creep or slippage that could result in damage to the shaft or housing bore.

TAP fit usually accompanies PRESS fit, for fitting the opposite ring to the stationary member, if the bearing rings are separable.

PUSH fit is used instead of TAP, for a stationary outer ring, if the bearing is non-separable.

HEAVY PRESS fit ("A" style) is an NTN-Bower innovation for cylindrical roller bearings. It is used to prevent the outer ring from turning in the housing bore, where the bearing is operating under very heavy loads. The outer ring O.D. is made oversize to provide a heavy press fit in a standard (tap fit) size housing bore. The accompanying inner ring uses a PRESS fit on the shaft.

The catalog fitting practice does not apply to bearings mounted on hollow shafts or in housings of materials softer than steel, such as aluminum. Since these conditions usually require heavier press fits, the NTN Engineering Department should be consulted for recommendation.

The chart on the opposite page summarizes the recommended fitting practice for various installations and bearing types, including bearings with inner or outer rings omitted.

Inner Ring PRESS Fit for Rotating Shaft

Basic Bearing Number	Bearing Dimensions		Shaft Diameter		Resultant Fit		ABMA Fit Class
	Inch/mm				.0001 Inch/Micrometers		
	Maximum	Minimum	Maximum	Minimum	Tight	Tight	
04	0.7874 20.000	0.7870 19.990	0.7881 20.017	0.7877 20.008	3T 8T	11T 27T	m5
05	0.9843 25.000	0.9839 24.990	0.9850 25.017	0.9846 25.008	3T 8T	11T 27T	
06	1.1811 30.000	1.1807 29.990	1.1818 30.017	1.1814 30.008	3T 8T	11T 27T	
07	1.3780 35.000	1.3776 34.988	1.3788 35.020	1.3784 35.009	4T 9T	12.5T 32T	
08	1.5748 40.000	1.5744 39.988	1.5756 40.020	1.5752 40.009	4T 9T	12.5T 32T	m6
09	1.7717 45.000	1.7713 44.988	1.7727 45.025	1.7721 45.009	4T 9T	14.5T 37T	
10	1.9685 50.000	1.9681 49.988	1.9695 50.025	1.9689 50.009	4T 9T	14.5T 37T	
11	2.1654 55.000	2.1648 54.985	2.1666 55.030	2.1658 55.011	4T 11T	18T 45T	n6
12	2.3622 60.000	2.3616 59.985	2.3634 60.030	2.3626 60.011	4T 11T	18T 45T	
13	2.5591 65.000	2.5585 64.985	2.5603 65.030	2.5595 65.011	4T 11T	18T 45T	
14	2.7559 70.000	2.7553 69.985	2.7574 70.039	2.7567 70.020	8T 20T	21T 54T	n6
15	2.9528 75.000	2.9522 74.985	2.9543 75.039	2.9536 75.020	8T 20T	21T 54T	
16	3.1496 80.000	3.1490 79.985	3.1511 80.039	3.1504 80.020	8T 20T	21T 54T	
17	3.3465 85.000	3.3457 84.980	3.3483 85.045	3.3474 85.023	9T 23T	26T 65T	
18	3.5433 90.000	3.5425 89.980	3.5451 90.045	3.5442 90.023	9T 23T	26T 65T	n6
19	3.7402 95.000	3.7394 94.980	3.7420 95.045	3.7411 95.023	9T 23T	26T 65T	
20	3.9370 100.000	3.9362 99.980	3.9388 100.045	3.9379 100.023	9T 23T	26T 65T	

Inner Ring PRESS Fit for Rotating Shaft (Cont.)

Basic Bearing Number	Bearing Dimensions		Shaft Diameter		Resultant Fit		ABMA Fit Class
	Inch/mm				.0001 Inch/Micrometers		
	Maximum	Minimum	Maximum	Minimum	Tight	Tight	
21	4.1339 105.000	4.1331 104.980	4.1357 105.045	4.1348 105.023	9T 23T	26T 65T	n6
22	4.3307 110.000	4.3299 109.980	4.3325 110.045	4.3316 110.023	9T 23T	26T 65T	
24	4.7244 120.000	4.7236 119.980	4.7262 120.045	4.7253 120.023	9T 23T	26T 65T	
26	5.1811 130.000	5.1171 129.975	5.1201 130.052	5.1192 130.027	11T 27T	30T 77T	
28	5.5118 140.000	5.5108 139.975	5.5138 140.052	5.5129 140.027	11T 27T	30T 77T	p6
30	5.9055 150.000	5.9045 149.975	5.9082 150.068	5.9072 150.043	17T 43T	37T 93T	
32	6.2292 160.000	6.2982 159.925	6.3019 160.068	6.3009 160.043	17T 43T	37T 93T	
34	6.6929 170.000	6.6919 169.975	6.6956 170.068	6.6946 170.043	17T 43T	37T 93T	
36	7.0866 180.000	7.0856 179.975	7.0893 180.068	7.0883 180.043	17T 43T	37T 93T	
38	7.4803 190.000	7.4791 189.970	7.4834 190.079	7.4823 190.050	20T 50T	43T 109T	
40	7.8740 200.000	7.8728 199.970	7.8771 200.079	7.8760 200.050	20T 50T	43T 109T	
44	8.6614 220.000	8.6602 219.970	8.6645 220.079	8.6634 220.050	20T 50T	43T 109T	
48	9.4488 240.000	9.4476 239.970	9.4519 240.079	9.4508 240.050	20t 50T	43t 109T	
52	10.2362 260.000	10.2348 259.965	10.2397 260.088	10.2384 260.056	22T 56T	49T 123T	
56	11.0236 280.000	11.0222 279.965	11.0271 280.088	11.0258 280.056	22T 56T	49T 123T	
60	11.8110 300.000	11.8096 299.965	11.8145 300.088	11.8132 300.056	22T 56T	49T 123T	
64	12.5984 320.000	12.5968 319.960	12.6023 320.098	12.6008 320.062	24T 62T	55T 138T	

Inner Ring TAP Fit for Stationary Shaft

Basic Bearing Number	Bearing Dimensions		Shaft Diameter		Resultant Fit		ABMA Fit Class
	Inch/mm				.0001 Inch/Micrometers		
	Maximum	Minimum	Maximum	Minimum	Loose	Tight	
04	0.7874 20.000	0.7870 19.990	0.7874 20.000	0.7869 19.987	5L 13L	4T 10T	
05	0.9843 25.000	0.9839 24.990	0.9843 25.000	0.9838 24.987	5L 13L	4T 10T	
06	1.1811 30.000	1.1807 29.990	1.1877 30.000	1.1806 29.987	5L 13L	4T 10T	
07	1.3780 35.000	1.3776 34.988	1.3780 35.000	1.3774 34.984	6L 16L	4.5T 12T	
08	1.5748 40.000	1.5744 39.988	1.5748 40.000	1.5742 39.984	6L 16L	4.5t 12t	
09	1.7717 45.000	1.7713 44.988	1.7717 45.000	1.7711 44.984	6L 16L	4.5T 12T	
10	1.9685 50.000	1.9681 49.988	1.9685 50.000	1.9679 49.984	6L 16L	4.5T 12T	
11	2.1654 55.000	2.1648 54.985	2.1654 55.000	2.1647 54.981	7L 19L	6T 15T	
12	2.3622 60.000	2.3616 59.985	2.3622 60.000	2.3615 59.981	7L 19L	6T 15T	
13	2.5591 65.000	2.5585 64.985	2.5591 65.000	2.5584 64.981	7L 19L	6T 15T	
14	2.7559 70.000	2.7553 69.985	2.7559 70.000	2.7552 69.981	7L 19L	6T 15T	
15	2.9528 75.000	2.9522 74.985	2.9528 75.000	2.9521 74.981	7L 19L	6T 15T	
16	3.1496 80.000	3.1490 79.985	3.1496 80.000	3.1489 79.981	7L 19L	6T 15T	
17	3.3465 85.000	3.3457 84.980	3.3465 85.000	3.3456 84.978	9L 22L	8T 20T	
18	3.5433 90.000	3.5425 89.980	3.5433 90.000	3.5424 89.978	9L 22L	8T 20T	
19	3.7402 95.000	3.7394 94.980	3.7402 95.000	3.7393 94.978	9L 22L	8T 20T	
20	3.9370 100.000	3.9362 99.980	3.9370 100.000	3.9361 99.978	9L 22L	8T 20T	

Inner Ring TAP Fit for Stationary Shaft (Cont.)

Basic Bearing Number	Bearing Dimensions		Shaft Diameter		Resultant Fit		ABMA Fit Class
	Inch/mm				.0001 Inch/Micrometers		
	Maximum	Minimum	Maximum	Minimum	Loose	Tight	
21	4.1339 105.000	4.1331 104.980	4.1339 105.000	4.1330 104.978	9L 22L	8T 20T	 h6
22	4.3307 110.000	4.3299 109.980	4.3307 110.000	4.3298 109.978	9L 22L	8T 20T	
24	4.7244 120.000	4.7236 119.980	4.7244 120.000	4.7235 119.978	9L 22L	8T 20T	
26	5.1181 130.000	5.1171 129.975	5.1181 130.000	5.1171 129.975	10L 25L	10T 25T	
28	5.5118 140.000	5.5108 139.975	5.5118 140.000	5.5108 139.975	10L 25L	10T 25T	
30	5.9055 150.000	5.9045 149.975	5.9055 150.000	5.9045 149.975	10L 25L	10T 25T	
32	6.2992 160.000	6.2982 159.975	6.2992 160.000	6.2982 159.975	10L 25L	10T 25T	
34	6.6929 170.000	6.6919 169.975	6.6929 170.000	6.6919 169.975	10L 25L	10T 25T	
36	7.0866 180.000	7.0856 179.975	7.0866 180.000	7.0856 179.975	10L 25L	10T 25T	
38	7.4803 190.000	7.4791 189.970	7.4803 190.000	7.4792 189.971	11L 29L	12T 30T	
40	7.8740 200.000	7.8728 199.970	7.8740 200.000	7.8729 199.971	11L 29L	12T 30T	
44	8.6614 220.000	8.6602 219.970	8.6614 220.000	8.6603 219.971	11L 29L	12T 30T	
48	9.4488 240.000	9.4476 239.970	9.4488 240.000	9.4477 239.971	11L 29L	12T 30T	
52	10.2362 260.000	10.2348 259.965	10.2362 260.000	10.2349 259.968	13L 32L	14T 35T	
56	11.0236 280.000	11.0222 279.965	11.0236 280.000	11.0223 279.968	13L 32L	14T 35T	
60	11.8110 300.000	11.8096 299.965	11.8110 300.000	11.8097 299.968	13L 32L	14T 35T	
64	12.5984 320.000	12.5968 319.960	12.5984 320.000	12.5970 319.964	14L 36L	16T 40T	

Outer Ring PUSH Fit for Non-Separable Bearings

Use with Press Fit Inner Ring

Basic Bearing Number				Bearing Outside Diameter		Housing Bore		Resultant Fit		ABMA Fit Class
1900	1000	1200 5200	1300 7300 5300	Inch/mm				.0001 Inch/Micrometers		
				Maximum	Minimum	Maximum	Minimum	Loose	Tight	
		204		1.8504 47.000	1.8495 46.989	1.8514 47.025	1.8504 47.000	14.5L 36L		
		205	304	2.0472 52.000	2.0467 51.987	2.0484 52.030	2.0472 52.000	17L 43L		
	006			2.1654 55.000	2.1649 54.987	2.1666 55.030	2.1654 55.000	17L 43L		
	007	206	305	2.4409 62.000	2.4404 61.978	2.4421 62.030	2.4409 62.000	17L 43L		
	008			2.6772 68.000	2.6767 67.987	2.6784 68.030	2.6772 68.000	17L 43L		
		207	306	2.8346 72.000	2.8341 71.987	2.8358 72.030	2.8346 72.000	17L 43L		
	009			2.9528 75.000	2.9523 74.987	2.9540 75.030	2.9528 75.000	17L 43L		
911	010	208	307	3.1496 80.000	3.1491 79.987	3.1508 80.030	3.1496 80.000	17L 43L		
912		209		3.3465 85.000	3.3459 84.985	3.3479 85.035	3.3465 85.000	20L 50L		
913	011	210	308	3.5433 90.000	3.5427 89.985	3.5447 90.035	3.5433 90.000	20L 50L		
	012			3.7402 95.000	3.7396 94.985	3.7416 95.035	3.7402 95.000	20L 50L		
914	013	211	309	3.9370 100.000	3.9364 99.985	3.9384 100.035	3.9370 100.000	20L 50L		
915				4.1339 105.000	4.1333 104.985	4.1353 105.035	4.1339 105.000	20L 50L		
916	014	212	310	4.3307 110.000	4.3301 109.985	4.3321 110.035	4.3307 110.000	20L 50L		
	015			4.5276 115.000	4.5270 114.985	4.5290 115.035	4.5276 115.000	20L 50L		
917		213	311	4.7244 120.000	4.7238 119.985	4.7258 120.035	4.7244 120.000	20L 50L		
918	016	214		4.9213 125.000	4.9206 124.982	4.9299 125.040	4.9213 125.000	23L 58L		
919	017	215	312	5.1181 130.000	5.1174 129.982	5.1197 130.040	5.1181 130.000	23L 58L		
920	018	216	313	5.5118 140.000	5.5111 139.982	5.5134 140.040	5.5118 140.000	23L 58L		
921	019			5.7087 145.000	5.7080 144.982	5.7103 145.040	5.7087 145.000	23L 58L		
922	020	217	314	5.9055 150.000	5.9048 149.982	5.9071 150.040	5.9055 150.000	23L 58L		
	021	218	315	6.2992 160.000	6.2982 159.975	6.3008 160.040	6.2992 160.000	26L 65L		
924				6.4961 165.000	6.4951 164.975	6.4977 165.040	6.4961 165.000	26L 65L		
	022	219	316	6.6929 170.000	6.6919 169.975	6.6945 170.040	6.6929 170.000	26L 65L		

Outer Ring PUSH Fit for Non-Separable Bearings (Cont.)

Use with Press Fit Inner Ring

Basic Bearing Number				Bearing Outside Diameter		Housing Bore		Resultant Fit		ABMA Fit Class
1900	1000	1200 5200	1300 7300 5300	Inch/mm				.0001 Inch/Micrometers		
				Maximum	Minimum	Maximum	Minimum	Loose	Tight	
926	024	220	317	7.0866 180.000	7.0856 179.975	7.0882 180.040	7.0866 180.000	26L 65L	LINE TO LINE 	H7
928		221	318	7.4803 190.000	7.4791 189.970	7.4821 190.046	7.4803 190.000	30L 76L		
	026	222	319	7.8740 200.000	7.8728 199.970	7.8758 200.046	7.8740 200.000	30L 76L		
930	028			8.2677 210.000	8.2665 209.970	8.2695 210.046	8.2677 210.000	30L 76L		
		224	320	8.4646 215.000	8.4634 214.970	8.4664 215.046	8.4646 215.000	30L 76L		
932				8.6614 220.000	8.6602 219.970	8.6632 220.046	8.6614 220.000	30L 76L		
	030		321	8.8583 225.000	8.8571 224.970	8.8601 225.046	8.8583 225.000	30L 76L		
934		226		9.0551 230.000	9.0539 229.970	9.0569 230.046	9.0551 230.000	30L 76L		
	032		322	9.4488 240.000	9.4476 239.970	9.4506 240.046	9.4488 240.000	30L 76L		
936		228		9.8425 250.000	9.8413 249.970	9.8443 250.046	9.8425 250.000	30L 76L		
938	034		324	10.2362 260.000	10.2348 259.965	10.2382 260.052	10.2362 260.000	34L 87L		
		230		10.6299 270.000	10.6285 269.965	10.6319 270.052	10.6299 270.000	34L 87L		
940	036		326	11.0236 280.000	11.0222 279.965	11.0256 280.052	11.0236 280.000	34L 87L		
	038	232		11.4173 290.000	11.4159 289.965	11.4193 290.052	11.4173 290.000	34L 87L		
944			328	11.8110 300.000	11.8096 299.965	11.8130 300.052	11.8110 300.000	34L 87L		
	040	234		12.2047 310.000	12.2033 309.965	12.2067 310.052	12.2047 310.000	34L 87L		
948		236	330	12.5984 320.000	12.5967 319.960	12.6006 320.057	12.5984 320.000	38L 97L		
	044	238	332	13.3858 340.000	13.3842 339.960	13.3880 340.057	13.3858 340.000	38L 97L		
952	048	240	334	14.1732 360.000	14.1716 359.960	14.1754 360.057	14.1732 360.000	38L 97L		
956			336	14.9606 380.000	14.9590 379.960	14.9628 380.057	14.9606 380.000	38L 97L		
	052	244	338	15.7480 400.000	15.7464 399.960	15.7502 400.057	15.7480 400.000	38L 97L		
960	056		340	16.5354 420.000	16.5336 419.955	16.5379 420.063	16.5354 420.000	43L 108L		
964		248		17.3228 440.000	17.3210 439.955	17.3253 440.063	17.3228 440.000	43L 108L		
		252		18.8976 480.000	18.8958 479.955	18.9001 480.063	18.8976 480.000	43L 108L		
		256		19.6850 500.000	19.6832 499.955	19.6875 500.063	19.6850 500.000	43L 108L		

Outer Ring TAP Fit for Rotating Shaft

Basic Bearing Number				Bearing Outside Diameter		Housing Bore		Resultant Fit		ABMA Fit Class
1900	1000	1200 5200	1300 7300 5300	Inch/mm				.0001 Inch/Micrometers		
				Maximum	Minimum	Maximum	Minimum	Loose	Tight	
		204		1.8504 47.000	1.8500 46.989	1.8510 47.014	1.8500 46.989	10.5L 25L	4T 11T	 J7
		205	304	2.0472 52.000	2.0467 51.987	2.0479 52.018	2.0467 51.988	12L 31L	5T 12T	
	006			2.1654 55.000	2.1649 54.987	2.1661 55.018	2.1649 54.988	12L 31L	5T 12T	
	007	206	305	2.4490 62.000	2.4404 61.987	2.4416 62.018	2.4404 61.988	12L 31L	5T 12T	
	008			2.6772 68.000	2.6767 67.987	2.6779 68.018	2.6767 67.988	12L 31L	5T 12T	
		207	306	2.8346 72.000	2.8341 71.987	2.8353 72.018	2.8341 71.988	12L 31L	5T 12T	
	009			2.9528 75.000	2.9523 74.987	2.9535 75.018	2.9523 74.988	12L 31L	5T 12T	
911	010	208	307	3.1496 80.000	3.1491 79.987	3.1503 80.018	3.1491 79.988	12L 31L	5T 12T	
912		209		3.3465 85.000	3.3459 84.985	3.3474 85.022	3.3460 84.987	15L 37L	5T 13T	
913	011	210	308	3.5433 90.000	3.5427 89.985	3.5442 90.022	3.5428 89.987	15L 37L	5T 13T	
	012			3.7402 95.000	3.7396 94.985	3.7411 95.022	3.7397 94.987	15L 37L	5T 13T	
914	013	211	309	3.9370 100.000	3.9364 99.985	3.9379 100.022	3.9365 99.987	15L 37L	5T 13T	
915				4.1339 105.000	4.1333 104.985	4.1348 105.022	4.1334 104.987	15L 37L	5T 13T	
916	014	212	310	4.3307 110.000	4.3301 109.985	4.3316 110.022	4.3302 109.987	15L 37L	5T 13T	
	015			4.5276 115.000	4.5270 114.985	4.5285 115.022	4.5271 114.987	15L 37L	5T 13T	
917		213	311	4.7244 120.000	4.7238 119.985	4.7253 120.022	4.7239 119.987	15L 37L	5T 13T	
918	016	214		4.9213 125.000	4.9206 124.982	4.9223 125.026	4.9207 124.986	17L 44L	6T 14T	
919	017	215	312	5.1181 130.000	5.1174 129.982	5.1191 130.026	5.1175 129.986	17L 44L	6T 14T	
920	018	216	313	5.5118 140.000	5.5111 139.982	5.5128 140.026	5.5112 139.986	17L 44L	6T 14T	
921	019			5.7087 145.000	5.7080 144.982	5.7097 145.026	5.7081 144.986	17L 44L	6T 14T	
922	020	217	314	5.9055 150.000	5.9048 149.982	5.9065 150.026	5.9049 149.986	17L 44L	6T 14T	
	021	218	315	6.2992 160.000	6.2982 159.975	6.3002 160.026	6.2986 159.986	20L 51L	6T 14T	
924				6.4961 165.000	6.4951 164.975	6.4971 165.026	6.4955 164.986	20L 51L	6T 14T	
	022	219	316	6.6929 170.000	6.6919 169.975	6.6939 170.026	6.6923 169.986	20L 51L	6T 14T	

Outer Ring TAP Fit for Rotating Shaft

Basic Bearing Number				Bearing Outside Diameter		Housing Bore		Resultant Fit		ABMA Fit Class
1900	1000	1200 5200	1300 7300 5300	Inch/mm				.001 Inch/Micrometers		
				Maximum	Minimum	Maximum	Minimum	Loose	Tight	
926	024	220	317	7.0866 180.000	7.0856 179.975	7.0876 180.026	7.0860 179.986	20L 51L	6T 14T	 J7
928		221	318	7.4030 190.000	7.4791 189.970	7.4815 190.030	7.4797 189.984	24L 60L	6T 16T	
	026	222	319	7.8740 200.000	7.8728 199.970	7.8752 200.030	7.8734 199.984	24L 60L	6T 16T	
930	028			8.2677 210.000	8.2665 209.970	8.2689 210.030	8.2671 209.984	24L 60L	6T 16T	
		224	320	8.4646 215.000	8.4634 214.970	8.4658 215.030	8.4640 214.984	24L 60L	6T 16T	
932				8.6614 220.000	8.6602 219.970	8.6626 220.030	8.6608 219.984	24L 60L	6T 16T	
	030		321	8.8583 225.000	8.8571 224.970	8.8595 225.030	8.8577 224.984	24L 60L	6T 16T	
934		226		9.0551 230.000	9.0539 229.970	9.0563 230.030	9.0545 229.984	24L 60L	6T 16T	
	032		322	9.4488 240.000	9.4476 239.970	9.4500 240.030	9.4482 239.984	24L 60L	6T 16T	
936		228		9.8425 250.000	9.8413 249.970	9.8437 250.030	9.8419 249.984	24L 60L	6T 16T	
938	034		324	10.2362 260.000	10.2348 259.965	10.2376 260.036	10.2356 259.984	28L 71L	6T 16T	
		230		10.6299 270.000	10.6285 269.965	10.6313 270.036	10.6293 269.984	28L 71L	6T 16T	
940	036		326	11.0236 280.000	11.0222 279.965	11.0250 280.036	11.0230 279.984	28L 71L	6T 16T	
	038	232		11.4173 290.000	11.4159 289.965	11.4187 290.036	11.4167 289.984	28L 71L	6T 16T	
944			328	11.8110 300.000	11.8096 299.965	11.8124 300.036	11.8104 299.984	28L 71L	6T 16T	
	040	234		12.2047 310.000	12.2033 309.965	12.2061 310.036	12.2041 309.984	28L 71L	6T 16T	
948		236	330	12.5984 320.000	12.5968 319.960	12.5999 320.039	12.5977 319.982	31L 79L	7T 18T	
	044	238	332	13.3858 340.000	13.3842 339.960	13.3873 340.039	13.3851 339.982	31L 79L	7T 18T	
952	048	240	334	14.1732 360.000	14.1716 359.960	14.1747 360.039	14.1725 359.982	31L 79L	7T 18T	
956			336	14.9606 380.000	14.9590 379.960	14.9621 380.039	14.9599 379.982	31L 79L	7T 18T	
	052	244	338	15.7480 400.000	15.7464 399.960	15.7495 400.039	15.7473 399.982	31L 79L	7T 18T	
960	056		340	16.5354 420.000	16.5336 419.955	16.5371 420.043	16.5346 419.980	35L 88L	8T 20T	
964		248		17.3228 440.000	17.3210 439.955	17.3245 440.043	17.3220 439.980	35L 88L	8T 20T	
		252		18.8976 480.000	18.8958 479.955	18.8993 480.043	18.8968 479.980	35L 88L	8T 20T	
		256		19.6850 500.000	19.6832 499.955	19.6867 500.043	19.6842 499.980	35L 88L	8T 20T	

Outer Ring PRESS Fit for Stationary Shaft

Basic Bearing Number				Bearing Outside Diameter		Housing Bore		Resultant Fit		ABMA Fit Class
1900	1000	1200 5200	1300 7300 5300	Inch/mm				.0001 Inch/Micrometers		
				Maximum	Minimum	Maximum	Minimum	Loose	Tight	
		204		1.8504 47.000	1.8500 46.989	1.8501 46.992	1.8491 46.967	1.5L 3L	13T 33T	 N7
		205	304	2.0472 52.000	2.0467 51.987	2.0468 51.991	2.0457 51.961	1L 4L	15T 39T	
	006			2.1654 55.000	2.1649 54.987	2.1650 54.991	2.1639 54.961	1L 4L	15T 39T	
	007	206	305	2.4409 62.000	2.4404 61.987	2.4405 61.991	2.4394 61.961	1L 4L	15T 39T	
	008			2.6772 68.000	2.6767 67.987	2.6768 67.991	2.6757 67.961	1L 4L	15T 39T	
		207	306	2.8346 72.000	2.8341 71.987	2.8342 71.991	2.8331 71.961	1L 4L	15T 39T	
	009			2.9528 75.000	2.9523 74.987	2.9524 74.991	2.9513 74.961	1L 4L	15T 39T	
911	010	208	307	3.1496 80.000	3.1491 79.987	3.1492 79.991	3.1481 79.961	1L 4L	15T 39T	
912		209		3.3465 85.000	3.3459 84.985	3.3461 84.990	3.3447 84.955	2L 5L	18T 45T	
913	011	210	308	3.5433 90.000	3.5427 89.985	3.5429 89.990	3.5415 89.955	2L 5L	18T 45T	
	012			3.7402 95.000	3.7396 94.985	3.7398 94.990	3.7384 94.955	2L 5L	18T 45T	
914	013	211	309	3.9370 100.000	3.9364 99.985	3.9366 99.990	3.9352 99.955	2L 5L	18T 45T	
915				4.1339 105.000	4.1333 104.985	4.1335 104.990	4.1321 104.955	2L 5L	18T 45T	
916	014	212	310	4.3307 110.000	4.3301 109.985	4.3303 109.990	4.3289 109.955	2L 5L	18T 45T	
	015			4.5276 115.000	4.5270 114.985	4.5272 114.990	4.5258 114.955	2L 5L	18T 45T	
917		213	311	4.7244 120.000	4.7238 119.985	4.7240 119.990	4.7226 119.955	2L 5L	18T 45T	
918	016	214		4.9213 125.000	4.9206 124.982	4.9208 124.988	4.9193 124.948	2L 6L	20T 52T	
919	017	215	312	5.1181 130.000	5.1174 129.982	5.1176 129.988	5.1161 124.948	2L 6L	20T 52T	
920	018	216	313	5.5118 140.000	5.5111 139.982	5.5113 139.988	5.5098 139.948	2L 6L	20T 52T	
921	019			5.7087 145.000	5.7080 144.982	5.7082 144.988	5.7067 144.948	2L 6L	20T 52T	
922	020	217	314	5.9055 150.000	5.9048 149.982	5.9050 149.982	5.9035 149.948	2L 6L	20T 52T	
	021	218	315	6.2992 160.000	6.2982 159.975	6.2987 159.988	6.2972 159.948	5L 13L	20T 52T	
924				6.4961 165.000	6.4951 164.975	6.4956 164.988	6.4941 164.948	5L 13L	20T 52T	
	022	219	316	6.6929 170.000	6.6919 169.975	6.6924 169.988	6.6909 169.948	5L 13L	20T 52T	

Outer Ring PRESS Fit for Stationary Shaft

Basic Bearing Number				Bearing Outside Diameter		Housing Bore		Resultant Fit		ABMA Fit Class
1900	1000	1200 5200	1300 7300 5300	Inch/mm				.0001 Inch/Micrometers		
				Maximum	Minimum	Maximum	Minimum	Loose	Tight	
926	024	220	317	7.0866	7.0856	7.0861	7.0846	5L	20T	 N7
				180.000	179.975	179.988	179.948	13L	52T	
928	026	222	319	7.4803	7.4791	7.4797	7.4779	6L	24T	
				190.000	189.970	189.986	189.940	16L	60T	
930	028	224	320	7.8740	7.8728	7.8734	7.8716	6L	24T	
				200.000	199.970	199.986	199.940	16L	60T	
932	030	226	321	8.2677	8.2665	8.2671	8.2653	6L	24T	
				210.000	209.970	209.986	209.940	16L	60T	
934	032	228	322	8.4646	8.4634	8.4640	8.4622	6L	24T	
				215.000	214.970	214.986	214.940	16L	60T	
938	034	230	324	8.6614	8.6602	8.6608	8.6590	6L	24T	
				220.000	219.970	219.986	219.940	16L	60T	
940	036	232	326	8.8583	8.8571	8.8577	8.8559	6L	24T	
				225.000	224.970	224.986	224.940	16L	60T	
944	038	234	328	9.0551	9.0539	9.0545	9.0527	6L	24T	
				230.000	229.970	229.986	229.940	16L	60T	
948	040	236	330	9.4488	9.4476	9.4482	9.4464	6L	24T	
				250.000	249.970	249.986	249.940	16L	60T	
952	044	238	332	10.2362	10.2348	10.2356	10.2336	8L	26T	
				260.000	259.965	259.986	259.934	21L	66T	
956	048	240	334	10.6299	10.6285	10.6293	10.6273	8L	26T	
				270.000	269.965	269.986	269.934	21L	66T	
960	052	244	338	11.0236	11.0222	11.0230	11.0210	8L	26T	
				280.000	279.965	279.986	279.934	21L	66T	
964	056	248	340	11.4173	11.4159	11.4167	11.4147	8L	26T	
				290.000	289.965	289.986	289.934	21L	66T	
		252		11.8110	11.8096	11.8104	11.8084	8L	26T	
				300.000	299.965	299.986	299.934	21L	66T	
		256		12.2047	12.2033	12.2041	12.2021	8L	26T	
				310.000	309.965	309.986	309.934	21L	66T	
				12.5984	12.5968	12.5978	12.5955	10L	29T	
				320.000	319.960	319.984	319.927	24L	73T	
				13.3858	13.3842	13.3852	13.3829	10L	29T	
				340.000	339.960	339.984	339.927	24L	73T	
				14.1732	14.1716	14.1726	14.1703	10L	29T	
				360.000	359.960	359.984	359.927	24L	73T	
				14.9606	14.9590	14.9600	14.9577	10L	29T	
				380.000	379.960	379.984	379.927	24L	73T	
				15.7480	15.7464	15.7474	15.7451	10L	29T	
				400.000	399.960	399.984	399.927	24L	73T	
				16.5354	16.5336	16.5347	16.5323	11L	31T	
				420.000	419.955	419.983	419.920	28L	80T	
				17.3228	17.3210	17.3221	17.3197	11L	31T	
				440.000	439.955	439.983	439.920	28L	80T	
				18.9876	18.8958	18.8969	18.8945	11L	31T	
				480.000	479.955	479.983	479.920	28L	80T	
				19.6850	19.6832	19.6843	19.6819	11L	31T	
				500.000	499.955	499.983	499.920	28L	80T	

Outer Ring HEAVY PRESS Fit

“A” Style Bearing with Oversize O.D. For Heavy Press Fit — Use with Press Fit Inner Ring

Basic Bearing Number				Bearing Outside Diameter		Housing Bore		Resultant Fit		ABMA Fit Class
1900	1000	1200 5200	1300 7300 5300	Inch/mm				.0001 Inch/Micrometers		
				Maximum	Minimum	Maximum	Minimum	Tight	Tight	
		204		1.8514 47.026	1.8510 47.015	1.8510 47.014	1.8500 46.989	.5L 1T	14T 37T	
		205	304	2.0482 52.024	2.0477 52.011	2.0479 52.018	2.0467 51.988	2L 7L	15T 36T	
	006			2.1665 55.029	2.1660 55.016	2.1661 55.018	2.1649 54.988	1L 2L	16T 41T	
	007	206	305	2.4421 62.029	2.4416 62.016	2.4416 62.018	2.4404 61.988	0L 2L	17T 41T	
	008			2.6785 68.034	2.6780 68.021	2.6779 68.018	2.6767 67.988	1T 3T	18T 46T	
		207	306	2.8359 72.032	2.8354 72.019	2.8353 72.018	2.8341 71.988	1T 1T	18T 44T	
	009			2.9542 75.037	2.9537 75.024	2.9535 75.018	2.9523 74.988	2T 6T	19T 49T	
911	010	208	307	3.1510 80.035	3.1505 80.022	3.1503 80.018	3.1491 79.988	2T 4T	19T 47T	
912		209		3.3480 85.039	3.3474 85.024	3.3474 85.022	3.3460 84.987	0T 2T	20T 52T	
913	011	210	308	3.5449 90.040	3.5443 90.025	3.5442 90.022	3.5428 89.987	1T 3T	21T 53T	
	012			3.7419 95.044	3.7413 95.029	3.7411 95.022	3.7397 94.987	2T 7T	22T 57T	
914	013	211	309	3.9388 100.046	3.9382 100.031	3.9379 100.022	3.9365 99.987	3T 9T	23T 59T	
915				4.1358 105.049	4.1352 105.034	4.1348 105.022	4.1334 104.987	4T 12T	24T 62T	
916	014	212	310	4.3329 110.056	4.3323 110.041	4.3316 110.022	4.3302 109.987	7T 19T	27T 69T	
	015			4.5298 115.057	4.5292 115.042	4.5285 115.022	4.5271 114.987	7T 20T	27T 70T	
917		213	311	4.7266 120.056	4.7260 120.041	4.7253 120.022	4.7239 119.987	7T 19T	27T 69T	
918	016	214		4.9236 125.059	4.9229 125.041	4.9223 125.026	4.9207 124.986	6T 15T	29T 73T	
919	017	215	312	5.1204 130.058	5.1197 130.040	5.1191 130.026	5.1175 129.986	6T 14T	29T 72T	
920	018	216	313	5.5141 140.058	5.5134 140.040	5.5128 140.026	5.5112 139.986	6T 14T	29T 72T	
921	019			5.7113 145.067	5.7106 145.049	5.7097 145.026	5.7081 144.986	9T 23T	32T 81T	
922	020	217	314	5.9081 150.066	5.9074 150.048	5.9065 150.026	5.9049 149.986	9T 22T	32T 80T	
	021	218	315	6.3020 160.071	6.3010 160.046	6.3002 160.026	6.2986 159.986	8T 20T	34T 85T	
924				6.4989 165.072	6.4979 165.047	6.4971 165.026	6.4955 164.986	8T 21T	34T 86T	
	022	219	316	6.6957 170.071	6.6947 170.046	6.6939 170.026	6.6923 169.986	8T 20T	34T 85T	

Outer Ring HEAVY PRESS Fit (Cont.)

“A” Style Bearing with Oversize O.D. For Heavy Press Fit — Use with Press Fit Inner Ring

Basic Bearing Number				Bearing Outside Diameter		Housing Bore		Resultant Fit		ABMA Fit Class
1900	1000	1200 5200	1300 7300 5300	Inch/mm				.0001 Inch/Micrometers		
				Maximum	Minimum	Maximum	Minimum	Tight	Tight	
926	024	220	317	7.0894	7.0884	7.0876	7.0860	8T	34T	
				180.071	180.046	180.026	179.986	20T	85T	
928	026	222	319	7.4833	7.4821	7.4815	7.4797	6T	36T	
				190.076	190.046	190.030	189.984	16T	92T	
930	028	224	320	7.8771	7.8759	7.8752	7.8734	7T	37T	
				200.078	200.048	200.030	199.984	18T	94T	
932	030	226	321	8.2709	8.2697	8.2689	8.2671	8T	38T	
				210.081	210.051	210.030	209.984	21T	97T	
934	032	228	322	8.4680	8.4668	8.4658	8.4640	10T	40T	
				215.087	215.057	215.030	214.984	27T	103T	
936	034	230	324	8.6649	8.6637	8.6626	8.6608	11T	41T	
				220.088	220.058	220.030	219.984	28T	104T	
938	036	232	326	8.8618	8.8606	8.8595	8.8577	11T	41T	
				225.090	225.060	225.030	224.984	30T	106T	
940	038	234	328	9.0587	9.0575	9.0563	9.0545	12T	42T	
				230.091	230.061	230.030	229.984	31T	107T	
944	040	236	330	9.4526	9.4514	9.4500	9.4482	14T	44T	
				240.096	240.066	240.030	239.984	36T	112T	
948	044	238	332	9.8463	9.8451	9.8437	9.8419	14T	44T	
				250.096	250.066	250.030	249.984	36T	112T	
952	048	240	334	10.2402	10.2388	10.2376	10.2356	12T	46T	
				260.101	260.066	260.036	259.984	30T	117T	
956	052	244	338	10.6339	10.6325	10.6313	10.6293	12T	46T	
				270.101	270.066	270.036	269.984	30T	117T	
960	056	248	340	11.0276	11.0262	11.0250	11.0230	12T	46T	
				280.101	280.066	280.036	279.984	30T	117T	
964	252	252	340	11.4216	11.4202	11.4187	11.4167	15T	49T	
				290.109	290.074	290.036	289.984	38T	125T	
966	256	256	340	11.8154	11.8140	11.8124	11.8104	16T	50T	
				300.111	300.076	300.036	299.984	40T	127T	
968	256	256	340	12.2091	12.2077	12.2061	12.2041	16T	50T	
				310.111	310.076	310.036	309.984	40T	127T	
970	256	256	340	12.6032	12.6016	12.5999	12.5977	17T	55T	
				320.121	320.081	320.039	319.982	42T	139T	
972	256	256	340	13.3906	13.3890	13.3873	13.3851	17T	55T	
				340.121	340.081	340.039	339.982	42T	139T	
974	256	256	340	14.1781	14.1765	14.1747	14.1725	18T	56T	
				360.124	360.084	360.039	359.982	45T	142T	
976	256	256	340	14.9655	14.9639	14.9621	14.9599	18T	56T	
				380.124	380.084	380.039	379.982	45T	142T	
978	256	256	340	15.7529	15.7513	15.7495	15.7473	18T	56T	
				400.124	400.084	400.039	399.982	45T	142T	
980	256	256	340	16.5406	16.5388	16.5371	16.5346	17T	60T	
				420.131	420.086	420.043	419.980	43T	151T	
982	256	256	340	17.3280	17.3262	17.3245	17.3220	17T	60T	
				440.131	440.086	440.043	439.980	43T	151T	
984	256	256	340	18.9029	18.9011	18.8993	18.8968	18T	61T	
				480.134	480.089	480.043	479.980	46T	154T	
986	256	256	340	19.6903	19.6885	19.6867	19.6842	18T	61T	
				500.134	500.089	500.043	499.980	46T	154T	

Shaft Diameter — Inner Ring Omitted

With Outer Ring TAP and HEAVY PRESS Fits for Rotating Shaft

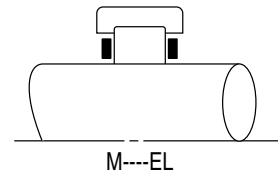
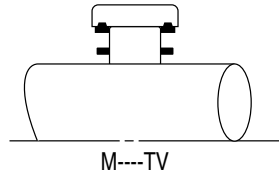

Basic Bearing Number	Shaft Diameter								Basic Bearing Number
	1900		1000		1200 5200		1300 7300 5300		
	Inch/mm								
	Maximum	Minimum	Maximum	Minimum	Maximum	Minimum	Maximum	Minimum	
04					1.1092 28.174	1.1087 28.161	1.1013 27.973	1.1008 27.960	04
05					1.2672 32.187	1.2667 32.174	1.3383 33.993	1.3378 33.980	05
06			1.4523 36.888	1.4518 36.875	1.4994 38.085	1.4989 38.072	1.6024 40.701	1.6019 40.688	06
07			1.6611 42.192	1.6606 42.179	1.7322 43.998	1.7317 43.985	1.8452 46.868	1.8447 46.855	07
08			1.8777 47.694	1.8772 47.681	1.9667 49.954	1.9662 49.941	2.0600 52.324	2.0595 52.311	08
09			2.0831 52.911	2.0825 52.896	2.1870 55.550	2.1864 55.535	2.3382 59.390	2.3376 59.375	09
10			2.2802 57.917	2.2796 57.902	2.3816 60.493	2.3810 60.478	2.5660 65.176	2.5654 65.161	10
11	2.4316 61.763	2.4310 61.748	2.5408 64.536	2.5402 64.521	2.6354 66.939	2.6348 66.924	2.8136 71.465	2.8130 71.450	11
12	2.6316 66.843	2.6310 66.828	2.7377 69.538	2.7371 69.523	2.8511 72.418	2.8505 72.403	3.0545 77.584	3.0538 77.566	12
13	2.8267 71.798	2.8261 71.783	2.9348 74.544	2.9341 74.526	3.1677 80.460	3.1670 80.442	3.2957 83.711	3.2950 83.693	13
14	3.0719 78.026	3.0712 78.008	3.1588 80.234	3.1581 80.216	3.3392 84.816	3.3385 84.798	3.5132 89.235	3.5125 89.217	14
15	3.2669 82.979	3.2662 82.961	3.3569 85.265	3.3562 85.247	3.5063 89.060	3.5056 89.042	3.7780 95.961	3.7772 95.941	15
16	3.4619 87.932	3.4612 87.914	3.5969 91.361	3.5962 91.343	3.7532 95.331	3.7525 95.313	4.0031 101.679	4.0023 101.659	16
17	3.7274 94.676	3.7267 94.658	3.7944 96.378	3.7936 96.358	4.0182 102.062	4.0174 102.042	4.2746 108.575	4.2738 108.555	17
18	3.9225 99.632	3.9217 99.612	4.0324 102.423	4.0316 102.403	4.2235 107.277	4.2227 107.257	4.4915 114.084	4.4907 114.064	18
19	4.1174 104.582	4.1166 104.562	4.2284 107.401	4.2276 107.381	4.4714 113.574	4.4706 113.554	4.8113 122.207	4.8105 122.187	19
20	4.3330 110.058	4.3322 110.038	4.4254 112.405	4.4246 112.385	4.7663 121.064	4.7655 121.044	5.1267 130.218	5.1258 130.195	20

NOTE: Shaft surface functioning as a bearing raceway must have a hardness of Rockwell C-58-64 and a maximum finish of 18 AA Deviation from this hardness or surface finish will require a reduction in the catalog load rating of the bearing. Consult NTN Engineering Department for a recommendation.

Shaft Diameter — Inner Ring Omitted

With Outer Ring PRESS Fit for Stationary Shaft

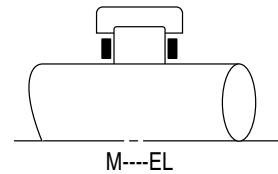
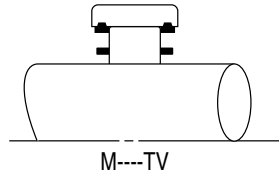

Basic Bearing Number	Shaft Diameter								Basic Bearing Number
	1900		1000		1200 5200		1300 7300 5300		
	Inch/mm								
	Maximum	Minimum	Maximum	Minimum	Maximum	Minimum	Maximum	Minimum	
04					1.1085 28.156	1.1080 28.143	1.1005 27.953	1.1000 27.940	04
05					1.2665 32.169	1.2660 32.156	1.3376 33.975	1.3371 33.962	05
06			1.4515 36.868	1.4510 36.855	1.4896 38.064	1.4981 38.051	1.6016 40.681	1.6011 40.688	06
07			1.6603 42.172	1.6598 42.159	1.7314 43.978	1.7309 43.965	1.8444 46.848	1.8439 46.835	07
08			1.8770 47.676	1.8765 47.663	1.9660 49.936	1.9655 49.923	2.0590 52.299	2.0585 52.286	08
09			2.0823 52.890	2.0817 52.875	2.1861 55.527	2.1855 55.512	2.3373 59.367	2.3367 59.352	09
10			2.2794 57.897	2.2788 57.882	2.3807 60.470	2.3801 60.455	2.5651 65.154	2.5645 65.139	10
11	2.4308 61.742	2.4302 61.727	2.5398 64.511	2.5392 64.496	2.6344 66.914	2.6338 66.899	2.8127 71.443	2.8121 71.428	11
12	2.6307 66.820	2.6301 66.805	2.7368 69.515	2.7362 69.500	2.8502 72.395	2.8496 72.380	3.0534 77.556	3.0527 77.538	12
13	2.8258 71.775	2.8252 71.760	2.9339 74.521	2.9332 74.503	3.1668 80.437	3.1661 80.419	3.2946 83.683	3.2939 83.665	13
14	3.0710 78.003	3.0703 77.985	3.1579 80.211	3.1572 80.193	3.3381 84.788	3.3374 84.770	3.5120 89.205	3.5113 89.187	14
15	3.2660 82.956	3.2653 82.938	3.3560 85.242	3.3553 85.224	3.5052 89.032	3.5045 89.014	3.7769 95.933	3.7761 95.913	15
16	3.4610 87.909	3.4603 87.891	3.5958 91.333	3.5951 91.315	3.7520 95.301	3.7513 95.283	4.0020 101.651	4.0012 101.631	16
17	3.7265 94.653	3.7258 94.635	3.7933 96.350	3.7925 96.330	4.0171 102.034	4.0163 102.014	4.2735 108.547	4.2727 108.527	17
18	3.9214 99.604	3.9206 99.584	4.0313 102.395	4.0305 102.375	4.2224 107.249	4.2216 107.229	4.4902 114.051	4.4894 114.031	18
19	4.1163 104.554	4.1155 104.534	4.2273 107.373	4.2265 107.353	4.4703 113.546	4.4695 113.526	4.8099 122.171	4.8091 122.151	19
20	4.3319 110.030	4.3311 110.010	4.4243 112.377	4.4235 112.357	4.7652 121.036	4.7644 121.016	5.1254 130.162	5.1245 130.162	20

NOTE: Shaft surface functioning as a bearing raceway must have a hardness of Rockwell C-58-64 and a maximum finish of 18 AA Deviation from this hardness or surface finish will require a reduction in the catalog load rating of the bearing. Consult NTN Engineering Department for a recommendation.

Housing Bore — Outer Ring Omitted
With Inner Ring TAP Fit for Stationary Shaft

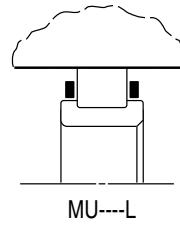
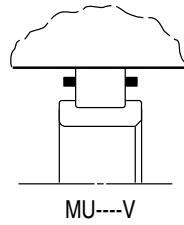

Basic Bearing Number	Shaft Diameter								Basic Bearing Number
	1900		1000		1200 5200		1300 7300 5300		
	Inch/mm								
	Maximum	Minimum	Maximum	Minimum	Maximum	Minimum	Maximum	Minimum	
04					1.6075 40.831	1.6070 40.818	1.7305 43.955	1.7300 43.942	04
05					1.7656 44.847	1.7651 44.834	2.1031 53.419	2.1026 53.406	05
06			1.9090 48.489	1.9085 48.476	2.1285 54.064	2.1280 54.051	2.3780 60.401	2.3775 60.388	06
07			2.1594 54.849	2.1589 54.836	2.4591 62.461	2.4586 62.448	2.6745 67.933	2.6740 67.920	07
08			2.3760 60.351	2.3755 60.338	2.7405 69.609	2.7400 69.596	3.0572 77.653	3.0567 77.640	08
09			2.6430 67.132	2.6424 67.117	2.9517 74.973	2.9511 74.958	3.3894 86.091	3.3888 86.076	09
10			2.8400 72.136	2.8394 72.121	3.1311 79.530	3.1305 79.515	3.7195 94.475	3.7189 94.460	10
11	2.8881 73.357	2.8875 73.342	3.1697 80.510	3.1691 80.495	3.4646 88.001	3.4640 87.986	4.0784 103.591	4.0778 103.567	11
12	3.0882 78.440	3.0876 78.425	3.3668 85.516	3.3662 85.501	3.8481 97.741	3.8475 97.726	4.4280 112.471	4.4273 112.453	12
13	3.2832 83.393	3.2826 83.378	3.5639 90.523	3.5632 90.505	4.1649 105.789	4.1642 105.771	4.7775 121.349	4.7768 121.331	13
14	3.6316 92.243	3.6309 92.225	3.9323 99.881	3.9316 99.863	4.3902 111.511	4.3895 111.493	5.0926 129.352	5.0919 129.334	14
15	3.8266 97.196	3.8259 97.178	4.1304 104.912	4.1297 104.894	4.5573 115.756	4.5566 115.738	5.4770 139.115	5.4762 139.095	15
16	4.0217 102.151	4.0210 102.133	4.4511 113.058	4.4504 113.040	4.9068 124.633	4.9061 124.615	5.8033 147.404	5.8025 147.384	16
17	4.3561 110.645	4.3554 110.627	4.6515 118.148	4.6507 118.128	5.2829 134.185	5.2821 134.165	6.1966 157.393	6.1958 157.373	17
18	4.5512 115.600	4.5504 115.580	5.0292 127.741	5.0284 127.721	5.5968 142.158	5.5960 142.138	6.5109 165.377	6.5101 165.357	18
19	4.7463 120.556	4.7455 120.536	5.2253 132.722	5.2245 132.702	5.9532 151.211	5.9524 151.191	6.8308 173.502	6.8300 173.482	19
20	5.1064 129.702	5.1056 129.682	5.4223 137.726	5.4215 137.706	6.3459 161.186	6.3451 161.166	7.2787 184.879	7.2778 184.856	20

NOTE: Shaft surface functioning as a bearing raceway must have a hardness of Rockwell C-58-64 and a maximum finish of 18 AA Deviation from this hardness or surface finish will require a reduction in the catalog load rating of the bearing. Consult NTN Engineering Department for a recommendation.

Housing Bore — Outer Ring Omitted

With Inner Ring PRESS Fit for Rotating Shaft

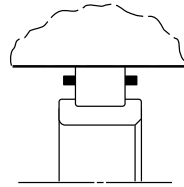

MU---V

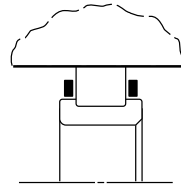

MU---L

Basic Bearing Number	Shaft Diameter								Basic Bearing Number
	1900		1000		1200 5200		1300 7300 5300		
	Inch/mm								
	Maximum	Minimum	Maximum	Minimum	Maximum	Minimum	Maximum	Minimum	
04					1.6080 40.843	1.6075 40.830	1.7309 43.965	1.7304 43.952	04
05					1.7661 44.859	1.7656 44.846	2.1036 53.432	2.1031 53.419	05
06			1.9096 48.504	1.9091 48.491	2.1291 54.079	2.1286 54.066	2.3785 60.414	2.3780 60.401	06
07			2.1600 54.864	2.1595 54.851	2.4597 62.477	2.4592 62.464	2.6751 67.948	2.6746 67.935	07
08			2.3767 60.368	2.3762 60.355	2.7411 69.624	2.7406 69.611	3.0578 77.668	3.0573 77.655	08
09			2.6438 67.152	2.6432 67.137	2.9526 74.996	2.9520 74.981	3.3902 86.111	3.3896 86.096	09
10			2.8409 72.159	2.8403 72.144	3.1319 79.550	3.1313 79.535	3.7203 94.498	3.7197 94.480	10
11	2.8892 73.385	2.8886 73.370	3.1707 80.536	3.1701 80.521	3.4656 88.026	3.4650 88.011	4.0793 103.614	4.0787 103.599	11
12	3.0893 78.468	3.0887 78.453	3.3678 85.542	3.3672 85.527	3.8491 97.767	3.8485 97.752	4.4289 112.494	4.4282 112.476	12
13	3.2843 83.421	3.2837 83.406	3.5649 90.549	3.5642 90.531	4.1658 105.812	4.1651 105.794	4.7785 121.374	4.7778 121.356	13
14	3.6329 92.276	3.6322 92.258	3.9337 99.916	3.9330 99.898	4.3914 111.544	4.3908 111.526	5.0938 129.383	5.0931 129.365	14
15	3.8280 97.231	3.8273 97.213	4.1317 104.945	4.1310 104.927	4.5585 115.786	4.5578 115.768	5.4782 139.146	5.4774 139.126	15
16	4.0230 102.184	4.0223 102.166			4.9081 124.666	4.9074 124.648	5.8045 147.434	5.8037 147.414	16
17	4.3578 110.688	4.3571 110.670			5.2845 134.226	5.2837 134.206	6.1981 157.431	6.1973 157.411	17
18	4.5529 115.643	4.5521 115.623	5.0309 127.785	5.0301 127.765	5.5984 142.199	5.5976 142.179	6.5124 165.415	6.5116 165.395	18
19	4.7480 120.599	4.7472 120.579	5.2269 132.763	5.2261 132.743	5.9548 151.252	5.9540 151.232	6.8322 173.538	6.8314 173.518	19
20	5.1082 129.748	5.1074 129.728	5.4240 137.769	5.4232 137.749	6.3474 161.224	6.3466 161.204	7.2802 184.917	7.2793 184.894	20

NOTE: Shaft surface functioning as a bearing raceway must have a hardness of Rockwell C-58-64 and a maximum finish of 18 AA Deviation from this hardness or surface finish will require a reduction in the catalog load rating of the bearing. Consult NTN Engineering Department for a recommendation.

Tapered Roller Bearings

Tapered roller bearings, due to tapered raceways and rollers, have the capability to support various combinations of thrust and radial loads. The thrust load capability varies with the cup angle; the greater the cup angle the greater is the ratio of thrust to radial rating.

Tapered roller bearings are manufactured by NTN-Bower in many different series to meet various application requirements. All the bearings in a series have the same internal construction and load carrying capability. Each series also include a number of cones which differ only in bore size and/or corner radius. Any cone within a given series may be combined with any cup in the same series and each combination will have the same load rating as discussed later in this catalog.

NTN-Bower makes various types of single row, two row and four row tapered roller bearings consisting of a variety of cone and cup configurations as described below:

Single Row Bearings (TS Type)

The TS type bearing is the most commonly used tapered roller bearing. It consists of a single cone and a single cup. The TS type is available in various bores, widths, outside diameters, and cup angles to provide a range of envelope dimensions and radial and thrust load ratings to meet various application requirements. The TS type bearing with a steeper cup angle can support a greater thrust load than a radial load.

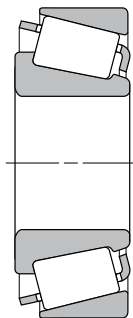

Flanged Cup Single Row Bearings (TSF Type)

The TSF type bearing consists of a single cone and a single cup flanged on its outside diameter. The cup flange is mounted against the side face of the housing eliminating the need for a shoulder inside the housing to support thrust loads. This feature permits through-boring of the housing to achieve a more accurate alignment for the cup seats. In other respects, the flanged cup bearings are similar to the TS type bearing described previously.

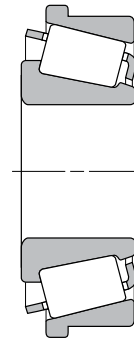

Double Cup Two Row Bearings (TDO Type)

Double cup two row bearings are manufactured in many of the same series as single row tapered roller bearings. The TDO type bearing consists of a double cup having one piece construction with two raceways, and two single cones. The TDO type bearing cup provides a groove with oil holes for lubrication. These bearings are available with or without cone spacers.

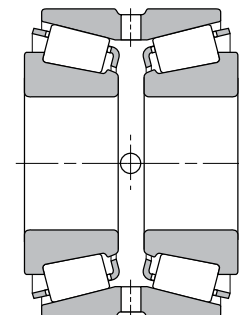

The TDO type bearing with the cone spacer is sold as a matched assembly to provide preset clearance for achieving optimum bearing life. It saves installation time by eliminating the need to adjust clearance during bearing installation in the system. The components for the TDO type bearing without cone spacer can be bought individually by the bearing user. In either case, the NTN Application Engineering Department should be consulted to determine the optimum clearance needed for the application. These bearings can support thrust loads in either direction and have radial load capabilities greater than the single row bearings.

The TDO type bearing is also available in a configuration designated as TDOCD type. This type of bearing is similar in every respect to the type TDO bearing except it has one of the lubrication holes counter-bored in the cup. By inserting a pin in this hole the cup can be locked in place against circumferential and axial movement in the housing.

The TDODC type version is also the same as the TDO type bearing except that the TDODC cup has no groove in the O.D. and only one hole counter-bored for pinning plus a lubrication passage.

Non-Adjustable Double Cup Two Row Bearings (TNA Type)

The TNA, TNACD, TNADC and TNASWE types for similar to TDO, TDOCD and TDODC types except the former types have the internal clearance controlled by flush-mounting the extended front faces of the cones against each other. Slots in the cone front face of the TNASWE type allow for the flow of lubricant. For most applications, the pre-set internal clearance is satisfactory, provided the recommended fitting practices are used.

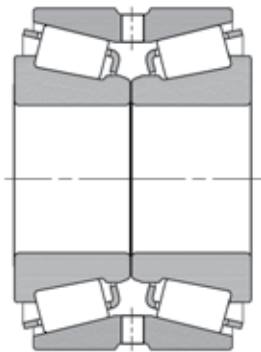

Double Cone Two Row Bearings (TDI Type)

The TDI type bearing consists of a double cone having one piece construction with two raceways, and two single cups. The bearing is available with or without a cup spacer. The TDI type bearing with a cup spacer is sold as a matched assembly to provide preset clearance for optimum bearing life. These bearings can support thrust loads in either direction, and have radial load capabilities greater than single row bearings.

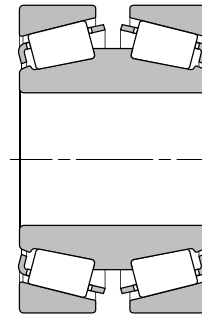

Double Cone Four Row Bearings (TQO Type)

The TQO type bearing consists of two double cones, one double cup, two single cups, one cone spacer and two cup spacers. The TQO type bearing has lubrication holes provided in the cup spacers, the cone spacer, and the double cup. The TQO type bearing is a matched assembly to provide the required end play for the application. This bearing can support thrust loads in either direction and has thrust and radial load capabilities greater than the TDI type and TDO type bearings. These bearings are normally used as work roll bearings in steel mills.

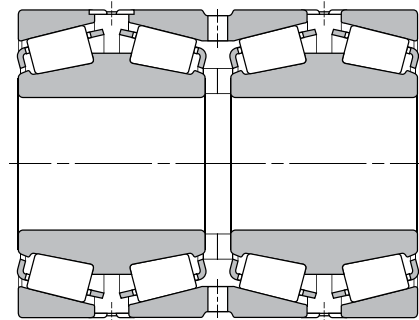

Bearing Design

True Rolling Contact

Tapered roller bearings have true rolling motion between rollers and raceways. The bearing is designed so that straight lines extended from the tapered surface of each roller and raceway contact meets at a common point called the apex located on the centerline of the bearing axis. This produces true rolling motion at each roller and raceway contact.

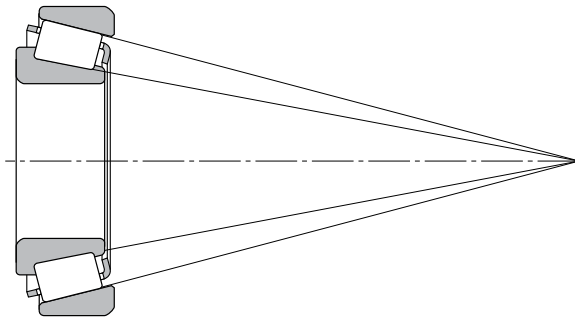

Crowned Rollers

NTN-Bower's pioneering efforts in developing crowned rollers have resulted in greater load carrying capability and longer bearing life. Crowned rollers under load distribute stress equally along their full length of contact with the raceways, thereby eliminating stress concentration at the roller ends. This design concept also compensates for minor misalignment between shaft and housing bore and deflection under load thereby reducing stress concentration.

Material

Cups, cones and rollers of NTN-Bower tapered roller bearing are made from case hardened alloy steel of "Bearing Quality" to provide superior fatigue life and reliability. Precise control of heat treatment, dimensions and surface finish of the components further contribute to reliable bearing performance. Premium steels and heat treatments are available for applications requiring extended life and high reliability.

Roller End-Rib Face Contact Geometry

Because the cup and cone raceway angles are different, the resultant forces between roller-cup contact and roller-cone contact are not equal. The difference between two resultant forces on each roller produces a seating force between the large end of the roller and the cone large rib. This seating force produces positive roller guidance. NTN-Bower tapered roller bearings have a spherical surface precision ground on the large end of the rollers. The large roller end and large rib face contact geometry is optimized to promote hydrodynamic lubrication to achieve lower operating temperature and bearing torque.

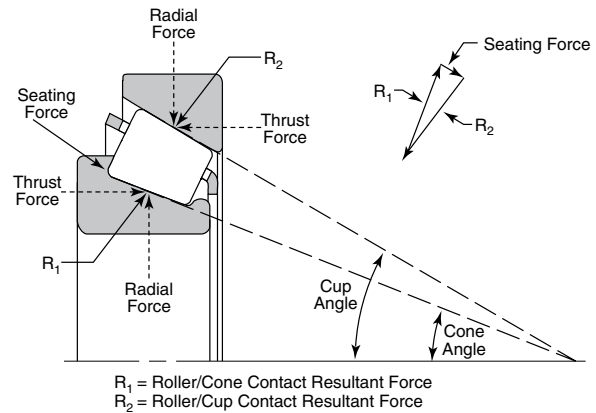

Nomenclature

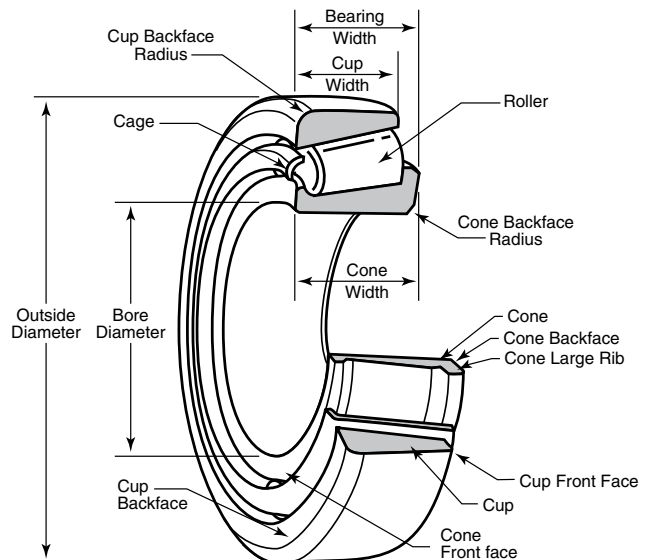

Bearing Selection by Bore Size

The Bearing Selection Chart by bore size is an aid to the design engineer in selecting the best single row bearing for the application. This chart identifies the minimum bearing outside diameter and minimum bearing width available in each series. This will aid in selecting a bearing where space is limited.

The bearing bore is normally selected for an application according to the required shaft size. After the design engineer has established the bearing bore size, this chart will identify all bearing series which include the required bore size plus information on the axial load factor and dynamic radial rating to assist in making the final bearing selection. This chart also refers to the page number where the detailed information about bearings in each series can be found. NTN Sales is available to assist in making the most economical bearing selection.

Bearing Boundary Dimensions				Dynamic Radial Rating * C _r	Axial Load Factors e Y ₂	Series Number	Page No.
Bore Diameter Range		Outside Diameter	Bearing Width				
Maximum	Minimum	Minimum	Minimum				
Inch/mm				lbs/N			
1.7812 45.242		3.0625 77.788	0.7812 19.842	12300 55000	0.43 1.41	LM603000	164
1.9375 49.212	1.7500 44.450	4.0625 103.188	1.7188 43.658	38500 171000	0.30 2.02	5300	131
1.9680 49.987	1.9375 49.212	4.5000 114.300	1.7500 44.450	44500 198000	0.40 1.49	HH506300	161
2.0000 50.800	1.7500 44.450	4.0000 101.600	1.2500 31.750	24700 110000	0.40 1.50	49500	141
2.0000 50.800	1.5000 38.100	4.0000 101.600	1.3750 34.925	30000 133000	0.29 2.10	525	120
2.0000 50.800	1.6250 41.275	4.1250 14.775	1.4375 36.512	31500 140000	0.40 1.49	59000	142
2.0000 50.800	1.7500 44.450	4.5000 114.300	1.7500 44.450	41000 183000	0.43 1.40	65300	143
2.0312 51.592	1.6250 41.275	3.5000 88.900	0.7874 20.000	17100 76000	0.32 1.88	365	116
2.0625 52.388	1.7500 44.450	3.6718 93.264	1.1875 30.162	22100 98000	0.34 1.77	3700	129
2.0625 52.388	1.7500 44.450	4.3750 111.125	1.1875 30.162	23400 104000	0.88 0.68	55000C	141
2.1250 53.975		4.1250 104.775	1.5313 38.895	33000 147000	0.34 1.79	4500	130
2.1250 53.975	1.5748 40.000	4.2500 107.950	1.4375 36.512	31500 140000	0.30 2.02	535	121
2.1250 53.975	1.7500 44.450	5.0000 127.000	2.0000 50.800	53000 236000	0.30 2.01	6200	131

Bearing Boundary Dimensions				Dynamic Radial Rating * C _r	Axial Load Factors e Y ₂	Series Number	Page No.
Bore Diameter Range		Outside Diameter	Bearing Width				
Maximum	Minimum	Minimum	Minimum				
Inch/mm				lbs/N			
2.1452 54.448	1.6250 41.275	4.1250 104.775	1.4375 36.512	32000 141000	0.49 1.23	HM807000	169
2.1654 55.000		4.3307 110.000	1.5354 39.000	38500 171000	0.35 1.73	H307700	159
2.2500 57.150	1.7500 44.450	4.1250 104.775	1.0938 27.783	25000 111000	0.34 1.79	455	118
2.2500 57.150	1.7500 44.450	4.1250 104.775	1.1875 30.162	28400 126000	0.33 1.80	45200	138
2.2500 57.150	2.0000 50.800	4.6250 117.475	1.3125 33.338	28300 126000	0.63 0.96	66000	143
2.2500 57.150	1.7500 44.450	4.7500 120.650	1.6250 41.275	38500 171000	0.31 1.91	615	123
2.2500 57.150	1.8750 47.625	4.8750 123.825	1.4375 36.512	35000 155000	0.74 0.81	72000C	145
2.2650 57.531	1.8750 47.625	3.8125 96.838	0.8268 21.000	16800 74500	0.35 1.69	385	116
2.3622 60.000	2.1250 53.975	4.8125 122.238	1.3125 33.338	29300 130000	0.67 0.90	66500	143
2.3750 60.325	2.0000 50.800	5.0000 127.000	1.7500 44.450	45000 200000	0.49 1.23	65000	143
2.4375 61.912	2.1250 53.975	5.1181 130.000	1.3169 33.449	32000 142000	0.82 0.73	HM911200	171
2.5000 63.500		3.7188 94.458	0.7500 19.050	13100 58500	0.42 1.41	L610500	164
2.5000 63.500		4.1250 104.775	0.8438 21.433	17700 79000	0.39 1.55	39000	137
2.5000 63.500	2.1250 53.975	5.3750 136.525	1.4375 36.512	39000 173000	0.87 0.69	78000C	147
2.5591 65.000		4.1339 105.000	0.9449 24.000	20400 91000	0.45 1.32	LM710900	165
2.5591 65.000		4.3307 110.000	1.1024 28.000	25300 113000	0.40 1.49	M511900	162
2.5591 65.000		4.7244 120.000	1.5354 39.000	41000 182000	0.34 1.78	H211700	153
2.5938 65.883	2.0000 50.800	4.7343 120.250	1.7188 43.658	42500 190000	0.36 1.67	5500	131
2.6250 66.675		4.0635 103.213	0.6930 17.602	15300 68000	0.49 1.23	L812100	169
2.6250 66.675	2.3622 60.000	4.2500 107.950	1.0000 25.400	20500 91500	0.46 1.31	29500	135
2.6250 66.675	2.0000 50.800	4.3301 109.985	1.1713 29.750	25300 113000	0.40 1.49	3900	130
2.6250 66.675	2.0000 50.800	4.4375 112.712	1.1875 30.162	31000 138000	0.34 1.77	39500	137
2.6250 66.675	2.3750 60.325	4.8125 122.238	1.5000 38.100	42000 186000	0.34 1.78	HM212000	153
2.6250 66.675	2.1679 54.988	5.3447 135.755	2.1250 53.975	59000 262000	0.32 1.85	6300	132
2.6250 66.675	2.3750 60.325	6.0000 152.400	2.0750 52.705	61500 275000	0.49 1.23	HH814500	170
2.6250 66.675	2.5000 63.500	7.0000 117.800	2.2500 57.150	72000 320000	0.80 0.75	HH914400	171

* Radial load ratings are based on 500 hrs. L₁₀ Life @ 33 1/3 rpm

Bearing Boundary Dimensions				Dynamic Radial Rating * C _r	Axial Load Factors e Y ₂	Series Number	Page No.
Bore Diameter Range		Outside Diameter	Bearing Width				
Maximum	Minimum	Minimum	Minimum				
Inch/mm				lbs/N			
2.6875 68.262	1.9685 50.000	4.3307 110.000	0.8661 22.000	18300 81500	0.40 1.49	395	117
2.6875 68.262	2.0000 50.800	4.8125 122.238	4.5000 38.100	35000 156000	0.35 1.73	555	121
2.6875 68.262		6.0000 152.400	1.8750 47.625	52500 235000	0.66 0.91	9100	133
2.7500 69.850		4.4375 112.712	0.8750 22.225	18700 83500	0.42 1.44	LM613400	164
2.7554 69.987		6.9375 176.212	2.1563 54.770	71500 320000	0.70 0.86	H916600	171
2.7559 70.000		4.3307 110.000	1.0236 26.000	21400 95000	0.49 1.23	LM813000	169
2.7559 70.000		4.5276 115.000	1.1417 29.000	27500 122000	0.43 1.40	M612900	164
2.7559 70.000	2.1654 55.000	4.7244 120.000	1.1418 29.002	26500 118000	0.38 1.56	475	119
2.7559 70.000		5.1181 130.000	1.6929 43.000	51000 227000	0.33 1.80	JF7000	133
2.7559 70.000	2.3617 59.987	5.7500 146.050	1.6250 41.275	43500 193000	0.78 0.77	H913800	171
2.8125 71.438	2.7500 69.850	4.7244 120.000	1.2813 32.545	33500 148000	0.36 1.67	47400	139
2.8125 71.438	2.1875 55.562	5.0000 127.000	1.4375 36.512	36000 160000	0.50 1.20	HM813800	169
2.8125 71.438	2.1250 53.975	5.1250 130.175	1.6250 41.275	43500 193000	0.36 1.66	635	123
2.8125 71.438	2.5000 63.500	5.3750 136.525	1.6250 41.275	50000 222000	0.36 1.67	H414200	161
2.8750 73.025	2.2500 57.150	4.6250 117.475	1.1730 29.794	25300 113000	0.44 1.38	33000	135
2.9062 73.817	2.7500 69.850	4.4375 112.712	1.0000 25.400	21400 95500	0.49 1.23	29600	135
2.9062 73.817	2.5000 63.500	5.0000 127.000	1.4375 36.512	36000 161000	0.36 1.65	565	121
2.9528 75.000		4.5276 115.000	0.9843 25.000	22000 98000	0.46 1.31	LM714100	166
2.9528 75.000		4.7244 120.000	1.2205 31.000	29400 131000	0.44 1.35	M714200	166
2.9528 75.000		5.7087 145.000	2.0079 51.000	64000 285000	0.36 1.66	H415600	161
3.0000 76.200		5.3438 135.733	1.7500 44.450	46500 207000	0.41 1.48	5700	131
3.0000 76.200	2.5575 64.960	5.8750 149.225	2.1250 53.975	64000 285000	0.36 1.66	6400	132
3.0000 76.200		6.3750 161.925	1.9375 49.212	55000 245000	0.71 0.85	9200	133
3.0000 76.200	2.0000 50.800	6.7500 161.925	1.9375 49.212	57000 255000	0.76 0.79	9300	133
3.0625 77.788		4.6250 117.475	1.0000 25.400	22400 99500	0.51 1.18	LM814800	170

Bearing Boundary Dimensions				Dynamic Radial Rating * C _r	Axial Load Factors e Y ₂	Series Number	Page No.
Bore Diameter Range		Outside Diameter	Bearing Width				
Maximum	Minimum	Minimum	Minimum				
Inch/mm				lbs/N			
3.0625 77.788	2.7540 69.952	4.7812 121.442	0.9343 23.731	19100 85000	0.45 1.33	34000	135
3.0625 77.788	3.0000 76.200	5.0000 127.000	1.1875 30.162	28900 129000	0.42 1.43	42600	138
3.0625 77.788	2.3750 60.325	5.3750 136.525	1.8125 46.038	50000 221000	0.47 1.27	H715300	166
3.1496 80.000		5.1181 130.000	1.3780 35.000	37000 164000	0.39 1.54	M515600	162
3.2500 82.550	2.8125 71.438	5.2500 133.350	1.3125 33.338	35000 155000	0.40 1.48	47600	139
3.2500 82.550	3.0000 76.200	5.2500 133.350	1.5625 39.688	40500 180000	0.40 1.49	HM516400	162
3.2500 82.550	2.8750 73.025	5.5115 139.992	1.4375 36.512	38000 170000	0.40 1.49	575	122
3.2813 83.345	3.0000 76.200	4.9375 125.412	1.0000 25.400	22100 98500	0.42 1.44	27600	134
3.3125 84.138	3.0000 76.200	6.7500 171.450	1.9375 49.212	75000 255000	0.76 0.79	9300	133
3.3125 84.138		7.6250 193.675	2.0472 52.000	69000 305000	0.79 0.75	H919900	171
3.3465 85.000		5.1181 130.000	1.1811 30.000	30500 135000	0.44 1.35	M716600	167
3.3465 85.000		5.9055 150.000	1.8110 46.000	11700 52000	0.33 1.81	H217200	153
3.3475 85.026	2.7500 69.850	5.9090 150.089	1.7500 44.450	58500 260000	0.33 1.84	745	125
3.3750 85.725	2.8125 71.438	5.2500 133.350	1.1875 30.162	28500 127000	0.44 1.35	495	119
3.3750 85.725		5.5960 142.138	1.6875 42.862	47000 210000	0.43 1.39	HM617000	165
3.3750 85.725	2.7500 69.850	5.7500 146.050	1.6250 41.275	46000 205000	0.41 1.47	655	124
3.5000 88.900		4.7812 121.442	0.5938 15.083	11700 52000	0.33 1.81	LL217800	153
3.5000 88.900		6.0000 152.400	1.5625 39.688	55000 245000	0.40 1.49	HM518400	162
3.5000 88.900	3.0000 76.200	6.3750 161.925	2.1250 53.975	68500 305000	0.40 1.50	6500	133
3.5000 88.900	2.7500 69.850	6.6250 168.275	2.1250 53.975	76500 340000	0.30 2.00	835	127
3.5423 89.974	3.1486 79.974	5.7864 146.975	1.5748 40.000	51000 226000	0.33 1.80	HM218200	153
3.5433 90.000		5.7087 145.000	1.3780 35.000	41000 183000	0.44 1.35	M718100	167
3.5433 90.000		6.1024 155.000	1.7323 44.000	60500 269000	0.34 1.76	HM318400	159
3.5625 90.488	2.8750 73.025	6.3750 161.925	1.8750 47.625	60500 269000	0.34 1.76	755	126
3.6210 91.973		5.6250 142.875	1.1811 30.000	29600 132000	0.48 1.25	LM718900	167

* Radial load ratings are based on 500 hrs. L₁₀ Life @ 33 1/3 rpm

Bearing Boundary Dimensions				Dynamic Radial Rating * C _r	Axial Load Factors e Y ₂	Series Number	Page No.
Bore Diameter Range		Outside Diameter	Bearing Width				
Maximum	Minimum	Minimum	Minimum				
Inch/mm				lbs/N			
3.7402 95.000		5.9055 150.000	1.3780 35.000	37500 167000	0.44 1.36	M719100	167
3.7500 95.250	3.3625 92.075	5.6250 142.875	1.3125 33.338	37000 165000	0.45 1.34	47800	139
3.7500 95.250	3.0000 76.200	5.8125 147.638	1.4062 35.717	40000 178000	0.44 1.36	595	122
3.7500 95.250	3.5000 88.900	6.7500 171.450	1.8750 47.625	62000 276000	0.37 1.63	77000	146
3.8125 96.838	3.4630 87.960	5.8437 148.430	1.1250 28.575	30500 136000	0.49 1.22	42000	137
3.8125 96.838	3.3465 85.000	7.4375 188.912	2.0000 50.800	61000 271000	0.87 0.69	90000	148
3.9360 99.974		6.1801 156.975	1.6535 42.000	56000 249000	0.33 1.80	HM220100	154
3.9370 100.000	3.7402 95.000	5.7087 145.000	0.9449 24.000	23900 106000	0.47 1.27	JP10000	134
3.9370 100.000		6.1024 155.000	1.4173 36.000	42500 189000	0.47 1.28	M720200	167
3.9370 100.000		6.2992 160.000	1.6142 41.000	52000 230000	0.47 1.28	HM720200	167
4.0000 101.600	3.7500 95.250	6.1875 157.162	1.4375 36.512	41500 186000	0.47 1.26	52000	141
4.0000 101.600	3.3750 85.725	6.6250 168.275	1.6250 41.275	50000 221000	0.47 1.28	675	125
4.0000 101.600	3.0000 76.200	7.4803 190.000	2.2500 57.150	97000 430000	0.33 1.79	HH221400	154
4.0000 101.600	3.5000 88.900	7.5000 190.500	2.2500 57.150	85500 380000	0.33 1.79	855	128
4.0000 101.600	3.1496 80.000	7.8740 200.000	2.0772 52.761	75500 335000	0.63 0.95	98000	150
4.0000 101.600		9.8750 250.825	3.0000 76.200	128000 570000	0.70 0.86	HH923600	171
4.1250 104.775	3.6250 92.075	73.1250 180.975	1.8750 47.625	64000 284000	0.39 1.56	775	126
4.2500 107.950	4.0000 101.600	5.7500 146.050	0.8438 21.433	19300 85500	0.39 1.53	L521900	162
4.2500 107.950		6.3750 161.925	1.3750 34.925	36000 160000	0.51 1.19	48100	140
4.2500 107.950	4.1875 106.362	6.5000 165.100	1.4375 36.512	42500 189000	0.50 1.21	56000	142
4.3125 109.538	4.2500 107.950	6.2500 158.750	0.9063 23.020	21800 97000	0.61 0.99	37000	136
4.3302 109.987	4.2500 107.950	6.2987 159.987	1.3750 34.925	38000 170000	0.40 1.49	LM522500	163
4.3307 110.000		6.4961 165.000	1.3780 35.000	42500 189000	0.50 1.21	M822000	170
4.3307 110.000		7.0866 180.000	1.8504 47.000	67500 300000	0.41 1.48	HM522600	163
4.5000 114.300		6.0000 152.400	0.8438 21.433	19800 88000	0.41 1.45	L623100	165
4.5000 114.300		6.2500 158.750	1.3750 34.925	38000 168000	.028 2.15	LM122900	151

Bearing Boundary Dimensions				Dynamic Radial Rating * C _r	Axial Load Factors e Y ₂	Series Number	Page No.
Bore Diameter Range		Outside Diameter	Bearing Width				
Maximum	Minimum	Minimum	Minimum				
Inch/mm				lbs/N			
4.5000 114.300	4.0000 101.600	8.1250 206.375	2.6250 66.675	104000 460000	0.33 1.84	935	129
4.5266 114.976	4.3297 109.974	7.0000 177.800	1.6250 41.275	52000 213000	0.52 1.16	64000	142
4.5266 114.976	3.9360 99.974	8.3750 212.725	2.6250 66.675	123000 545000	0.33 1.84	HH224300	155
4.5310 115.087	4.1250 104.775	7.5000 190.500	1.8750 47.625	67500 300000	0.42 1.44	71000	145
4.6250 117.475	4.5000 114.300	7.0856 179.974	1.3750 34.925	37000 164000	0.50 1.21	68000	145
4.7500 120.650		6.3125 160.338	0.8438 21.433	20500 91000	0.43 1.38	L624500	165
4.7500 120.650		6.7812 172.242	1.4063 35.720	46000 205000	0.33 1.80	M224700	155
4.7500 120.650		7.5000 190.500	1.8125 46.038	71500 315000	0.43 1.41	HM624700	165
4.7500 120.650	4.5000 114.300	10.7500 273.050	3.2500 82.550	164000 730000	0.63 0.95	HH926700	171
5.0000 127.000		6.5313 165.895	0.7188 18.258	17800 79500	0.33 1.80	LL225700	155
5.0000 127.000	4.7500 120.650	6.6875 169.862	1.0000 25.400	28600 127000	0.33 1.80	L225800	155
5.0000 127.000	4.8758 123.825	7.1875 182.562	1.5625 39.688	50500 224000	0.31 1.97	48200	140
5.0000 127.000	4.7500 120.650	101.0000 254.000	3.0625 77.788	163000 725000	0.32 1.87	HH228300	155
5.0312 127.792	4.5000 114.300	9.0000 228.600	2.1250 53.975	92000 410000	0.74 0.81	HM926700	172
5.0625 128.588		7.5000 190.500	1.3750 34.925	44000 196000	0.65 0.92	48000	140
5.1250 130.175	4.7500 120.650	8.1250 206.375	1.8750 47.625	70000 310000	0.46 1.31	795	127
5.1870 131.750	4.7227 119.957	8.1875 207.962	2.1250 53.975	84000 375000	0.26 2.27	HM127400	152
5.2500 133.350	5.0000 127.000	7.7500 196.850	1.8125 46.038	68500 305000	0.34 1.74	67300	143
5.2500 133.350	4.7500 120.650	9.0551 230.000	2.5000 63.500	114000 510000	0.37 1.62	95000	149
5.3750 136.525	5.2500 133.350	7.5000 190.500	1.5625 39.688	53000 236000	0.32 1.87	48300	140
5.5000 139.700		7.1250 180.975	0.8438 21.433	21700 96500	0.37 1.64	LL428300	161
5.5000 139.700	5.0000 127.000	8.4636 214.975	1.8750 47.625	71500 315000	0.49 1.23	74000	146
5.5000 139.700	5.3750 136.525	9.0000 228.600	2.2500 57.150	98000 435000	0.42 1.43	895	128
5.5118 140.000		7.6772 195.000	1.1417 29.000	42000 188000	0.50 1.19	JP14000	134
5.6250 142.875		7.8750 200.025	1.6250 41.275	53500 238000	0.34 1.78	48600	140

* Radial load ratings are based on 500 hrs. L₁₀ Life @ 33 1/3 rpm

Bearing Boundary Dimensions				Dynamic Radial Rating [*] C _r	Axial Load Factors e Y ₂	Series Number	Page No.
Bore Diameter Range		Outside Diameter	Bearing Width				
Maximum	Minimum	Minimum	Minimum				
Inch/mm				lbs/N			
5.7500 146.050		7.6250 193.675	1.1250 28.575	37500 167000	0.37 1.63	36600	136
5.7500 146.050		8.0000 203.200	1.7756 45.100	57000 255000	0.33 1.80	M229300	155
5.7500 146.050	5.0000 127.000	12.0000 304.800	3.5000 88.900	184000 800000	0.73 0.82	HH932100	172
5.8750 149.225	5.7500 146.050	9.3125 236.538	2.2500 57.150	109000 485000	0.32 1.88	HM231100	156
5.8750 149.225	5.5000 139.700	9.3125 236.538	2.2500 57.150	97000 430000	0.44 1.36	82000	147
6.0000 152.400		7.5625 192.088	0.9843 25.000	34500 153000	0.42 1.44	L630300	165
6.0000 152.400		8.7500 222.250	1.8437 46.830	69500 310000	0.33 1.80	M231600	156
6.0000 152.400		9.6250 244.475	1.8750 47.625	74000 330000	0.35 1.71	81000	147
6.0000 152.400	5.5000 139.700	10.0000 254.000	2.6250 66.675	120000 535000	0.41 1.47	99000	151
6.0000 152.400	5.7500 146.050	10.5625 268.288	2.9375 74.612	148000 660000	0.39 1.55	107000	151
6.0000 152.400		12.1250 307.975	3.5000 88.900	228000 1010000	0.33 1.79	HH234000	156
6.0000 152.400		12.1250 307.975	3.5000 88.900	192000 855000	0.33 1.84	450000	161
6.0625 153.988	5.7500 146.050	9.6250 244.475	1.8750 47.625	74000 330000	0.35 1.71	81000	147
6.2500 158.750		8.0938 205.583	0.9375 23.812	28500 127000	0.37 1.61	L432300	161
6.3120 160.325		11.3750 288.925	3.0709 78.000	192000 855000	0.35 1.73	H337800	160
6.5000 165.100		9.1339 232.000	1.7717 45.000	77000 345000	0.39 1.53	M533300	163
6.5000 165.100		10.0000 254.000	1.8125 46.038	89000 395000	0.32 1.88	M235100	156
6.5625 166.688	6.2500 158.750	8.8750 225.425	1.6250 41.275	57000 253000	0.38 1.57	46700	139
6.6250 168.275		13.0000 330.200	3.3750 85.725	193000 860000	0.81 0.74	H936300	172
6.6929 170.000		9.0551 230.000	1.5354 39.000	62000 277000	0.38 1.57	HM534100	163
6.6929 170.000	6.2992 160.000	9.4488 240.000	1.8110 46.000	79000 350000	0.44 1.37	M734400	167
6.7500 171.450		10.2500 260.350	2.6250 66.675	120000 530000	0.40 1.49	HM535300	163
6.8750 174.625		11.7500 298.450	3.2500 82.550	170000 755000	0.38 1.59	219000	154
7.0000 177.800		8.9375 227.012	1.1875 30.162	40000 179000	0.44 1.36	36900	136
7.0000 177.800	6.5000 165.100	9.7500 247.650	1.8750 47.625	75500 335000	0.44 1.36	67700	144
7.0000 177.800	6.8750 174.625	10.2500 260.350	2.1250 53.975	29000 129000	1.76	M236800	156
7.0000 177.800	6.3120 160.325	11.3750 288.925	2.5000 63.500	44500 198000	1.83	HM237500	156

Bearing Boundary Dimensions				Dynamic Radial Rating [*] C _r	Axial Load Factors e Y ₂	Series Number	Page No.
Bore Diameter Range		Outside Diameter	Bearing Width				
Maximum	Minimum	Minimum	Minimum				
Inch/mm				lbs/N			
7.0000 177.800	6.5000 165.100	11.3750 288.925	2.5000 63.500	121000 535000	0.47 1.28	94000	149
7.0866 180.000		9.8425 250.000	1.8504 47.000	81000 360000	0.48 1.25	M736100	167
7.3750 187.325	7.0000 177.800	10.6250 269.875	2.1875 55.562	101000 450000	0.33 1.80	M238800	157
7.4803 190.000		10.2362 260.000	1.8110 46.000	80500 355000	0.48 1.26	M738200	167
7.7500 196.850		9.5000 241.300	0.9375 23.812	36000 160000	0.42 1.44	LL639200	165
7.5000 190.500		13.2500 336.550	3.8750 98.425	227000 1010000	0.58 1.04	HH840200	170
7.5000 190.500	7.0000 177.800	16.8750 428.625	4.1875 106.362	250000 1110000	0.76 0.79	350000	160
7.5625 192.088	7.2500 184.150	10.5000 266.700	1.8750 47.625	78500 350000	0.48 1.26	67800	144
7.6250 193.765	7.3750 187.325	11.1250 282.575	2.0000 50.800	79500 355000	0.42 1.44	87000	148
7.7500 196.850		10.1250 257.175	1.5625 39.688	60500 269000	0.45 1.34	LM739700	168
7.8740 200.000		11.8110 300.000	2.5591 65.000	135000 600000	0.52 1.15	HM840400	170
8.0000 203.200		10.8750 276.225	1.6875 42.862	81500 365000	0.32 1.88	LM241100	157
8.0625 204.788	7.8750 200.025	11.5000 292.100	2.2813 57.945	118000 525000	0.33 1.80	M241500	157
8.2500 209.550	8.0000 203.200	11.1250 282.575	1.8125 46.038	80000 355000	0.51 1.18	67900	145
8.2500 209.550	7.0856 179.974	12.5000 317.500	2.5000 63.500	135000 600000	0.52 1.15	93000	149
8.5000 215.900	8.3750 212.725	11.2500 285.750	1.8125 46.038	81500 360000	0.48 1.25	LM742700	168
8.6602 219.969	8.5000 215.900	11.4177 290.010	1.2500 31.750	45500 202000	0.39 1.56	543000	163
8.6875 220.662		12.3750 314.325	2.4375 61.912	135000 600000	0.33 1.80	M244200	157
9.1250 231.775		10.5625 268.288	0.8858 22.500	29200 130000	0.33 1.80	LL244500	157
9.1250 231.775	9.0000 228.600	11.8125 300.038	1.3125 33.338	46500 207000	0.40 1.19	544000	163
9.2500 234.950		12.3750 314.325	1.9375 49.212	107000 475000	0.34 1.75	LM545800	163
9.2500 234.950	9.0000 228.600	14.0000 355.600	2.6875 68.262	141000 625000	0.59 1.02	96000	150
9.2500 234.950	7.8750 200.025	15.1250 384.175	4.4375 112.712	320000 430000	0.33 1.80	H247500	157
9.3125 236.538	9.0000 228.600	12.6250 320.675	1.7500 44.450	88000 390000	0.49 1.23	88000	148
9.3437 237.330	9.1250 231.775	13.2500 336.550	2.5625 65.088	160000 710000	0.33 1.80	M246900	157
9.5000 241.300	9.0000 228.600	12.8750 327.025	2.0625 52.388	104000 465000	0.41 1.48	8500	133

* Radial load ratings are based on 500 hrs. L₁₀ Life @ 33 1/3 rpm

Bearing Boundary Dimensions				Dynamic Radial Rating ⁺ C _r	Axial Load Factors e Y ₂	Series Number	Page No.
Bore Diameter Range		Outside Diameter	Bearing Width				
Maximum	Minimum	Minimum	Minimum				
Inch/mm				lbs/N			
9.5000 241.300		13.7460 349.148	2.2500 57.150	129000 575000	0.35 1.70	127000	152
9.5000 241.300	9.4930 241.122	14.5000 368.300	2.6875 68.262	168000 745000	0.34 1.75	125000	151
9.7500 247.650		13.6250 346.075	2.5000 63.500	156000 695000	0.34 1.75	M348400	160
9.7500 247.650		15.0000 381.000	3.2500 82.550	237000 1060000	0.31 1.95	HM150100	152
10.0000 254.000		13.6875 347.662	1.7500 44.450	105000 465000	0.33 1.80	LM249700	157
10.0000 254.000	9.0000 228.600	14.1250 358.775	2.8125 71.438	182000 810000	0.33 1.80	M249700	158
10.1250 257.175		13.5000 342.900	2.2500 57.150	134000 595000	0.35 1.73	M349500	160
10.2500 260.350		16.5000 419.100	3.3750 85.725	217000 965000	0.60 0.99	435000	161
10.2500 260.350		16.6250 422.275	3.3906 86.121	247000 1100000	0.33 1.80	HM252300	158
10.5000 266.700	10.3750 263.525	12.8125 325.438	1.1250 28.575	47500 211000	0.37 1.64	38800	137
10.5000 266.700	10.3750 263.525	14.0000 355.600	2.2500 57.150	138000 615000	0.36 1.67	LM451300	161
10.6250 269.875	9.2500 234.950	15.0000 381.000	2.9375 74.612	195000 865000	0.33 1.80	M252300	158
11.0312 280.192	11.0236 280.000	16.0000 406.400	2.7500 69.850	206000 915000	0.39 1.55	128000	152
11.2500 285.750	11.0229 279.982	14.9960 380.898	2.5625 65.088	149000 660000	0.43 1.39	LM654600	165
11.5000 292.100	11.0000 279.400	14.7500 374.650	1.8750 47.625	105000 470000	0.40 1.49	L555200	164
11.5000 292.100	11.0000 279.400	18.5000 469.900	3.7500 95.250	279000 1240000	0.38 1.59	722000	167
11.8125 300.038		16.6250 422.275	3.2500 82.550	230000 1020000	0.34 1.78	HM256800	158
12.0000 304.800		15.5000 393.700	2.0000 50.800	117000 520000	0.36 1.67	L357000	160
12.0000 304.800		16.0000 406.400	2.5000 63.800	152000 657000	0.44 1.36	LM757000	168
12.0000 304.800		19.6830 499.948	4.0000 101.600	241000 1070000	1.17 0.51	M959400	172
12.3750 314.325		19.5000 495.300	4.7500 120.650	385000 1720000	0.58 1.04	H859000	170
12.5000 317.500		17.6250 447.675	3.3750 85.725	256000 1140000	0.33 1.79	HM259000	159
12.7500 323.850		15.0000 381.000	1.1250 28.575	50000 222000	0.44 1.36	LL758700	168
13.0000 330.200		16.3750 415.925	1.8750 47.625	128000 570000	0.42 1.42	L659600	165
13.0000 330.200		16.3750 415.925	1.8750 47.625	98500 435000	0.50 1.20	L860000	170

Bearing Boundary Dimensions				Dynamic Radial Rating ⁺ C _r	Axial Load Factors e Y ₂	Series Number	Page No.
Bore Diameter Range		Outside Diameter	Bearing Width				
Maximum	Minimum	Minimum	Minimum				
Inch/mm				lbs/N			
13.0000 330.200		19.0000 482.600	3.3750 85.725	310000 1370000	0.39 1.54	526000	163
13.1250 333.375		18.5000 469.900	3.5625 90.488	310000 1370000	0.33 1.79	HM261000	159
13.5000 342.900		17.9960 457.098	2.6875 68.2620	166000 735000	0.71 0.84	LM961500	172
13.6250 346.075		19.2500 483.950	3.7500 95.250	31000 1390000	0.33 1.79	HM262700	159
13.6250 346.075	12.5000 317.500	20.0000 508.000	4.0625 103.187	425000 1890000	0.31 1.95	HM162600	153
14.0000 355.600		17.5000 444.500	2.3750 60.325	146000 650000	0.31 1.95	L163100	153
14.6250 371.475	14.0000 355.600	19.7500 501.650	2.9375 74.612	203000 900000	0.44 1.36	230000	155
14.7500 374.650		17.0000 431.800	1.1250 28.575	55000 246000	0.33 1.80	LL264600	159
15.0000 381.000	14.7500 374.650	20.5625 522.287	3.3750 85.724	274000 1220000	0.39 1.56	LM565900	164
15.1250 384.175	15.0000 381.000	19.2500 486.950	4.2500 107.950	505000 2240000	0.33 1.80	HM267100	159
15.1250 384.175	15.0000 381.000	21.5000 546.100	4.1250 104.775	375000 1680000	0.33 1.80	HM266400	159
15.1875 385.762		20.2500 514.350	3.2500 82.550	253000 2570000	0.42 1.43	LM665900	165
16.3750 415.925	15.0000 381.000	23.2500 590.550	4.5000 114.300	465000 2070000	0.33 1.80	M268700	159
16.3750 415.925		23.2500 590.550	5.0000 127.000	585000 2590000	0.29 2.05	HM168600	153
18.0000 457.200	17.0000 431.800	21.7500 552.450	1.7499 44.448	121000 540000	0.32 1.88	80000	147
18.0000 457.200		23.5000 596.900	3.0000 76.200	251000 1120000	0.40 1.48	244000	157
18.0000 457.200	17.7500 450.850	23.7500 603.250	3.3750 85.725	297000 1320000	0.45 1.32	LM770900	168
19.0000 462.600	18.0000 457.200	24.2500 615.950	3.3750 85.725	335000 1490000	0.33 1.80	LM272200	159
19.2500 488.950		24.9950 634.873	3.3125 84.137	315000 1390000	0.47 1.27	LM772700	168
19.2500 488.950	19.2390 488.671	26.0000 660.400	3.6875 93.662	350000 1550000	0.31 1.95	640000	165

* Radial load ratings are based on 500 hrs. L₁₀ Life @ 33 1/3 rpm

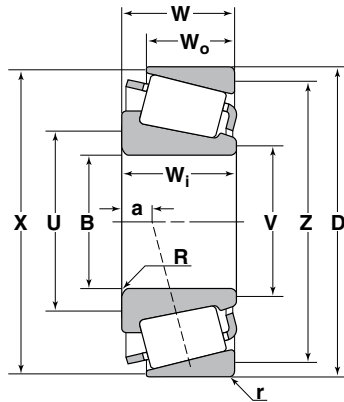

TS Type

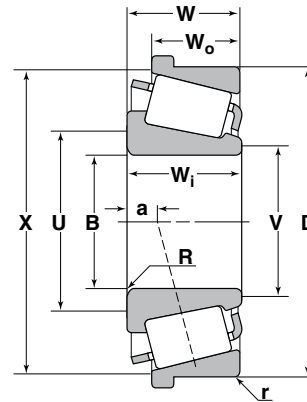

TSF Type

Dimensions

The basic boundary dimensions (bore, outside diameter, width) in the following tables conform to the standards established by ABMA/ANSI.

A description of dimensions represented by various letters is given below:

- B** Nominal cone bore diameter. The tolerance is given on pages 198–199 and the range is in the “Fitting Practice” section
- Wi** Nominal cone width. The tolerance is given on pages 198–199
- R** Maximum fillet on the shaft that the bearing corner will clear
- a** The distance from the cone backface to the effective load center
- U** Recommended minimum shaft shoulder diameter
- V** Recommended minimum shaft shoulder diameter
- D** Nominal cup outside diameter. The tolerance is given on pages 198–199 and the range is in the “Fitting Practice” section
- Wo** Nominal cup width. The tolerance is given on pages 198–199
- r** Maximum fillet in the housing that the bearing corner will clear

- X** Recommended maximum housing shoulder diameter for TSF Type
- Z** Recommended maximum housing shoulder diameter for TS Type
- W** Nominal bearing width. The tolerance is given on pages 198–199

Dimensions shown in the tables are given in both inch and metric units and are based on:

- 1 inch = 25.4 mm exactly**
- 1 micrometer = 1µm = 10⁻⁶ m**
- 1 micrometer = .001 mm**

Load Ratings

The radial load ratings in this catalog are based on 500 hrs L_{10} life at 33 1/3 rpm or 1 million cycles for either cone or cup rotation. To convert this rating to 3000 hrs L_{10} life at 500 rpm or 90 million cycles basis, divide by 3.857.

The load ratings, dynamic and static, are shown in both pounds and newtons.

- 1 pound = 4.448 newtons**

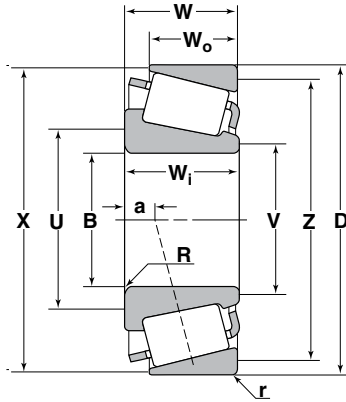

TS Type

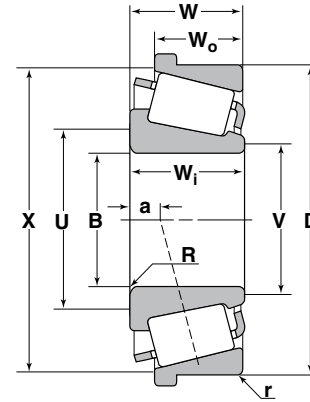

TSF Type

Basic Load Ratings		Axial Load Factor e Y_2	Cone Number	B	W_i	R	a	U	V	Cup Number	D	W_o	r	X	Z	W
Dynamic C_r	Static C_{or}			Bore Diameter	Cone Width	Maximum Shaft Fillet Radius*	Effective Load Center†	Minimum Shaft Shoulder Diameter	Minimum Shaft Shoulder Diameter		Outside Diameter	Cup Width	Maximum Housing Fillet Radius*	Maximum Housing Shoulder Diameter	Maximum Housing Shoulder Diameter	Bearing Width
lbs/N				Inch/mm						Inch/mm						
17100 76000	20200 90000	0.32 1.88	365 Series													
			365	1.9685 50.000	0.8750 22.225	0.08 2.0	-0.17 -4.3	2.28 58.0	2.17 55.0	362	3.5433 90.000	0.6250 15.875	0.08 2.0	3.31 84.0	3.19 81.0	0.7874 20.000
			365A	1.6250 41.275	0.8750 22.225	0.14 3.5	-0.17 -4.3	2.17 55.0	1.91 48.5	362A	3.5000 88.900	0.6501 16.513	0.05 1.3	3.31 84.0	3.19 81.0	0.8125 20.638
			365S	1.9375 49.212	0.8750 22.225	0.03 0.8	-0.17 -4.3	2.17 55.0	2.13 54.0	▲ 362B	3.5433 90.000	0.6250 15.875	0.03 0.8	3.39 86.0	—	0.7874 20.000
			366	1.9685 50.000	0.8750 22.225	0.09 2.3	-0.17 -4.3	2.32 59.0	2.17 55.0	363	3.5433 90.000	0.7874 20.000	0.03 0.8	3.34 85.0	3.23 82.0	0.7874 20.000
			367	1.7717 45.000	0.8750 22.225	0.08 2.0	-0.17 -4.3	2.17 55.0	2.01 51.0							
			368	2.0000 50.800	0.8750 22.225	0.06 1.5	-0.17 -4.3	2.28 58.0	2.20 56.0							
			368A	2.0000 50.800	0.8750 22.225	0.14 3.5	-0.17 -4.3	2.44 62.0	2.20 56.0							
			368S	2.0312 51.592	0.8750 22.225	0.08 2.0	-0.17 -4.3	2.32 59.0	2.20 56.0							
			369A	1.8750 47.625	0.8750 22.225	0.14 3.5	-0.17 -4.3	2.36 60.0	2.09 53.0							
			369AS	1.8750 47.625	.8750 22.225	0.09 2.3	-0.17 -4.3	2.24 57.0	2.09 53.0							
4640 20600	2540 11300	1.83	369S	1.8750 47.625	0.8750 22.225	0.09 2.3	-0.17 -4.3	2.24 57.0	2.09 53.0							
4640 20600	2540 11300	1.83	370A	2.0000 50.800	0.8750 22.225	0.20 5.0	-0.17 -4.3	2.56 65.0	2.20 56.0							
16800 74500	20600 91500	0.35 1.69	385 Series													
			385	2.1654 55.000	0.8640 21.946	0.09 2.3	-0.12 -3.0	2.56 65.0	2.40 61.0	382	3.8750 98.425	0.7018 17.826	0.03 0.8	3.62 92.0	3.54 90.0	0.8268 21.000
			385A	2.0000 50.800	0.8640 21.946	0.09 2.3	-0.12 -3.0	2.40 61.0	2.36 60.0	382A	3.8125 98.425	0.6250 17.826	0.03 0.8	3.62 92.0	3.50 90.0	0.8268 21.000
			385AX	2.0000 50.800	0.8640 21.946	0.03 0.8	-0.12 -3.0	2.28 58.0	2.28 58.0	382B	3.8125 96.838	0.7018 17.826	0.03 0.8	3.70 94.0	—	0.8268 21.000

* The maximum fillet on the shaft or in the housing that the bearing corner will clear.
 † Positive value indicates the effective load center is outside the backface of the cone.
 ▲ For additional "B" cup dimensions, see pages 173 to 174.
 ■ For parts with a "J" prefix, use metric tolerances given on page 199 and fitting practice given on page 201.
 ★ Designate bearings with hollow rollers and pinned-type retainers.
 ◆ Bearing is equipped with seals (and in some instances side rings).

Basic Load Ratings		Axial Load Factor $e Y_2$	Cone Number	B	W_i	R	a	U	V	Cup Number	D	W_o	r	X	Z	W
Dynamic C_r	Static C_{or}			Bore Diameter	Cone Width	Maximum Shaft Fillet Radius *	Effective Load Center †	Minimum Shaft Shoulder Diameter	Minimum Shaft Shoulder Diameter		Outside Diameter	Cup Width	Maximum Housing Fillet Radius *	Maximum Housing Shoulder Diameter	Maximum Housing Shoulder Diameter	Bearing Width
lbs/N				Inch/mm								Inch/mm				
16800 74500	20600 91500	0.35 1.69	385 Series (Cont'd)													
			385X	2.1654 55.000	0.8640 21.946	0.14 3.5	-0.12 -3.0	2.64 6.7	2.40 61.0	382S	3.8125 96.838	0.7982 20.274	0.09 2.3	3.58 91.0	3.43 87.0	1.0000 25.400
			386A	1.8750 47.625	0.8640 21.946	0.03 0.8	-0.12 -3.0	2.20 56.0	2.17 55.0	383A	3.9370 100.000	0.7018 17.826	0.08 2.0	3.66 93.0	3.50 89.0	0.8268 21.000
			387	2.2500 57.150	0.8640 21.946	0.09 2.3	-0.12 -3.0	2.60 66.0	2.44 62.0							
			387A	2.2500 57.150	0.8640 21.946	0.14 3.5	-0.12 -3.0	2.72 69.0	2.44 62.0							
			387AS	2.2500 57.150	0.8640 21.946	0.20 5.0	-0.12 -3.0	2.83 72.0	2.44 62.0							
			387S	2.2500 57.150	0.8640 21.946	0.03 0.8	-0.12 -3.0	2.48 63.0	2.44 62.0							
			388A	2.2650 57.531	0.8640 21.946	0.14 3.5	-0.12 -3.0	2.72 69.0	2.48 63.0							
			389	2.1880 55.575	0.8640 21.946	0.09 2.3	-0.12 -3.0	2.56 65.0	2.40 61.0							
			389A	2.1250 53.975	0.8640 21.946	0.03 0.8	-0.12 -3.0	2.40 61.0	2.36 60.0							
18300 81500	24100 107000	0.40 1.49	395 Series													
			390	2.2500 57.150	0.8660 21.996	0.09 2.3	-0.03 -0.8	2.76 70.0	2.60 66.0	394A	4.3307 110.000	0.7411 18.824	0.05 1.3	4.11 104.0	3.98 101.0	0.8661 22.000
			390A	2.5000 63.500	0.8660 21.996	0.06 1.5	-0.03 -0.8	2.87 73.0	2.76 70.0	▲ 394AB	4.3307 110.000	0.7411 18.824	0.04 1.0	4.17 106.0	— —	0.8661 22.000
			392	2.4375 61.912	0.8660 21.996	0.03 0.8	-0.03 -0.8	2.76 70.0	2.72 69.0	394AS	4.3307 110.000	0.7411 18.824	0.13 3.3	4.11 104.0	3.90 99.0	0.8661 22.000
			395	2.5000 63.500	0.8660 21.996	0.14 3.5	-0.03 -0.8	3.03 77.0	2.76 70.0	394CS	4.4680 113.487	0.7411 18.824	0.05 1.3	4.11 104.0	3.98 101.0	0.8661 22.000
			395A	2.6250 66.675	0.8660 21.996	0.03 0.8	-0.03 -0.8	2.87 73.0	2.87 73.0							
			395S	2.6250 66.675	0.8660 21.996	0.14 3.5	-0.03 -0.8	3.11 79.0	2.87 73.0							
			396	1.9685 50.000	0.8660 21.996	0.03 0.8	-0.03 -0.8	2.40 61.0	2.36 60.0							
			397	2.3622 60.000	0.8660 21.996	0.03 0.8	-0.03 -0.8	2.72 69.0	2.86 68.0							
			398	2.0000 50.800	0.8660 21.996	0.03 0.8	-0.03 -0.8	2.44 62.0	2.40 61.0							
			399A	2.6875 68.262	0.8660 21.996	0.09 2.3	-0.03 -0.8	3.07 78.0	2.91 74.0							
			399AS	2.6875 68.262	0.8660 21.996	0.20 5.0	-0.03 -0.8	3.27 83.0	2.91 74.0							
			395CS	2.6250 66.675	0.9230 23.444	0.14 3.5	-0.09 -2.3	3.11 79.0	2.87 73.0	394A	4.3307 110.000	0.7411 18.824	0.05 1.3	4.11 104.0	3.98 101.0	0.9231 23.448
										▲ 394AB	4.3307 110.000	0.7411 18.824	0.04 1.0	4.17 106.0	— —	0.9231 23.448

* The maximum fillet on the shaft or in the housing that the bearing corner will clear.
† Positive value indicates the effective load center is outside the backface of the cone.
▲ For additional "B" cup dimensions, see pages 173 to 174.
■ For parts with a "J" prefix, use metric tolerances given on page 199 and fitting practice given on page 201.
★ Designate bearings with hollow rollers and pinned-type retainers.
◆ Bearing is equipped with seals (and in some instances side rings).

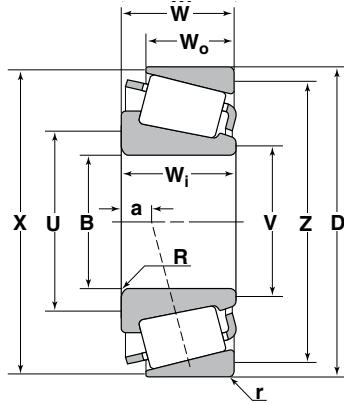

TS Type

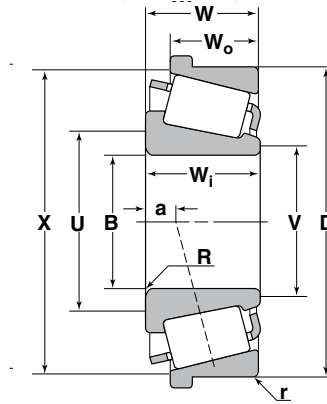

TSF Type

Basic Load Ratings		Axial Load Factor e Y_2	Cone Number	B	W_i	R	a	U	V	Cup Number	D	W_o	r	X	Z	W
Dynamic C_r	Static C_{or}			Bore Diameter	Cone Width	Maximum Shaft Fillet Radius †	Effective Load Center †	Minimum Shaft Shoulder Diameter	Minimum Shaft Shoulder Diameter		Outside Diameter	Cup Width	Maximum Housing Fillet Radius †	Maximum Housing Shoulder Diameter	Maximum Housing Shoulder Diameter	Bearing Width
lbs/N				Inch/mm						Inch/mm						
18300 81500	24100 107000	0.40 1.49	395 Series (Cont'd)							394AS	4.3307 110.000	0.7411 18.824	0.13 3.3	4.11 104.0	3.90 99.0	0.9231 23.448
										394CS	4.4680 113.487	0.7411 18.824	0.05 1.3	4.11 104.0	3.98 101.0	0.9231 23.448
			395ES	2.6250 66.675	1.2060 30.632	0.14 3.5	-0.37 -9.4	3.11 79.0	2.87 73.0	394A	4.3307 110.000	0.7411 18.824	0.05 1.3	4.11 104.0	3.98 101.0	1.2061 30.636
										▲ 394AB	4.3307 110.000	0.7411 18.824	0.04 1.0	4.17 106.0	—	1.2061 30.636
										394AS	4.3307 110.000	0.7411 18.824	0.13 3.3	4.11 104.0	3.90 99.0	1.2061 30.636
										394CS	4.4680 113.487	0.7411 18.824	0.05 1.3	4.11 104.0	3.98 101.0	1.2061 30.636
25000 111000	32000 142000	0.34 1.79	455 Series							452	4.2500 107.950	1.0630 27.000	0.03 0.8	3.94 100.0	3.90 99.0	1.2818 32.558
			455	2.0000 50.800	1.1542 29.317	0.03 0.8	-0.28 -7.1	2.36 60.0	2.32 59.0	453A	4.2500 107.950	0.8750 22.225	0.03 0.8	3.94 100.0	3.82 97.0	1.0938 27.783
			455S	2.0000 50.800	1.1542 29.317	0.14 3.5	-0.28 -7.1	2.56 65.0	2.32 59.0	▲ 453B	4.2500 107.950	0.8750 22.225	0.03 0.8	3.94 100.0	—	1.0938 27.783
			456	2.1250 53.975	1.1542 29.317	0.14 3.5	-0.28 -7.1	2.68 68.0	2.40 61.0	453X	4.1250 104.775	0.9687 24.605	0.13 3.3	3.86 98.0	3.62 92.0	1.1875 30.162
			458S	1.7717 45.000	1.1542 29.317	0.09 2.3	-0.28 -7.1	2.24 57.0	2.09 53.0	454	4.3307 110.000	1.0630 27.000	0.08 2.0	3.94 100.0	3.78 96.0	1.0943 27.795
			460	1.7500 44.450	1.1542 29.317	0.14 3.5	-0.28 -7.1	2.36 60.0	2.13 54.0							
			462	2.2500 57.150	1.1542 29.317	0.09 2.3	-0.28 -7.1	2.64 67.0	2.48 63.0							
			462A	2.2500 57.150	1.1542 29.317	0.09 2.3	-0.28 -7.1	2.64 67.0	2.66 67.6							

* The maximum fillet on the shaft or in the housing that the bearing corner will clear.
 † Positive value indicates the effective load center is outside the backface of the cone.
 ▲ For additional "B" cup dimensions, see pages 173 to 174.
 ■ For parts with a "J" prefix, use metric tolerances given on page 199 and fitting practice given on page 201.
 ★ Designate bearings with hollow rollers and pinned-type retainers.
 ◆ Bearing is equipped with seals (and in some instances side rings).

Basic Load Ratings		Axial Load Factor e_{Y_2}	Cone Number	B	W_1	R	a	U	V	Cup Number	D	W_0	r	X	Z	W	
Dynamic C_r	Static C_{or}			Bore Diameter	Cone Width	Maximum Shaft Fillet Radius †	Effective Load Center†	Minimum Shaft Shoulder Diameter	Minimum Shaft Shoulder Diameter		Outside Diameter	Cup Width	Maximum Housing Fillet Radius *	Maximum Housing Shoulder Diameter	Maximum Housing Shoulder Diameter	Maximum Housing Shoulder Diameter	Bearing Width
lbs/N				Inch/mm									Inch/mm				
25000 111000	32000 142000	0.34 1.79	455 Series (Cont'd)														
			463	1.8750 47.625	1.1542 29.317	0.19 4.8	-0.28 -7.1	2.56 65.0	2.20 56.0								
			466	2.1649 54.998	1.1542 29.317	0.09 2.3	-0.28 -7.1	2.60 66.0	2.44 62.0								
			467	1.8750 47.625	1.1542 29.317	0.03 0.8	-0.28 -7.1	2.24 57.0	2.20 56.0								
			468	2.0625 52.388	1.1542 29.317	0.06 1.5	-0.28 -7.1	2.44 62.0	2.36 60.0								
			469	2.2500 57.150	1.1542 29.317	0.14 3.5	-0.28 -7.1	2.76 70.0	2.48 63.0								
26500 118000	36000 160000	0.38 1.56	475 Series														
			475	2.1654 55.000	1.1420 29.007	0.03 0.8	-0.16 -4.1	2.64 67.0	2.60 66.0	472	4.7244 120.000	0.9542 24.237	0.08 2.0	4.49 114.0	4.21 107.0	1.1730 29.794	
			476	2.3622 60.000	1.1420 29.007	0.08 2.0	-0.16 -4.1	2.87 73.0	2.72 69.0	472A	4.7244 120.000	0.9230 23.444	0.13 3.3	4.49 114.0	4.17 106.0	1.1418 29.002	
			477	2.5000 63.500	1.1420 29.007	0.03 0.8	-0.16 -4.1	2.87 73.0	2.83 72.0	472B	4.7244 120.000	0.9542 24.237	0.03 0.8	4.53 115.0	— —	1.1730 29.794	
			478	2.5591 65.000	1.1420 29.007	0.09 2.3	-0.16 -4.1	3.03 77.0	2.87 73.0	472X	4.8750 123.825	0.9687 24.605	0.13 3.3	4.49 114.0	4.21 107.0	1.1875 30.636	
			479	2.6250 66.675	1.1420 29.007	0.09 2.3	-0.16 -4.1	3.07 78.0	2.91 74.0	473	4.7244 120.000	1.1417 29.000	0.08 2.0	4.29 111.0	4.37 109.0	1.1730 30.636	
			480	2.6875 68.262	1.1420 29.007	0.14 3.5	-0.16 -4.1	3.23 82.0	2.95 75.0								
			482	2.7500 69.850	1.1420 29.007	0.14 3.5	-0.16 -4.1	3.27 83.0	3.03 77.0								
			483	2.5000 63.500	1.1420 29.007	0.14 3.5	-0.16 -4.1	3.07 78.0	2.83 72.0								
			484	2.7559 70.000	1.1420 29.007	0.08 2.0	-0.16 -4.1	3.15 80.0	3.03 77.0								
28500 127000	41500 186000	0.44 1.35	495 Series														
			495	3.2500 82.550	1.1720 29.769	0.14 3.5	-0.03 -0.8	3.82 97.0	3.54 90.0	492A	5.2500 133.350	0.8750 22.225	0.13 3.3	5.04 128.0	4.72 120.0	1.1875 30.636	
			495A	3.0000 76.200	1.1720 29.769	0.14 3.5	-0.03 -0.8	3.62 92.0	3.39 86.0	493	5.3750 136.525	0.8750 22.225	0.13 3.3	5.12 130.0	4.80 122.0	1.1875 30.162	
			495AS	3.0625 77.788	1.1720 29.769	0.14 3.5	-0.03 -0.8	3.66 93.0	3.43 87.0	▲ 493B	5.3750 136.525	0.8750 22.225	0.13 3.3	5.16 131.0	— —	1.1875 30.162	
			495AX	3.0000 76.200	1.1720 29.769	0.25 6.4	-0.03 -0.8	3.86 98.0	3.39 86.0								
			495S	2.8125 71.438	1.1720 29.769	0.14 3.5	-0.03 -0.8	3.46 88.0	3.23 82.0								
			496	3.1875 80.962	1.1720 29.769	0.14 3.5	-0.03 -0.8	3.74 95.0	3.50 89.0								

* The maximum fillet on the shaft or in the housing that the bearing corner will clear.
 † Positive value indicates the effective load center is outside the backface of the cone.
 ▲ For additional "B" cup dimensions, see pages 173 to 174.
 ■ For parts with a "J" prefix, use metric tolerances given on page 199 and fitting practice given on page 201.
 ★ Designate bearings with hollow rollers and pinned-type retainers.
 ◆ Bearing is equipped with seals (and in some instances side rings).

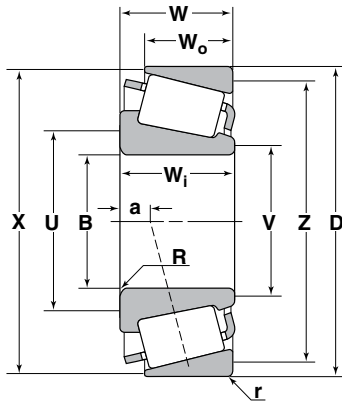

TS Type

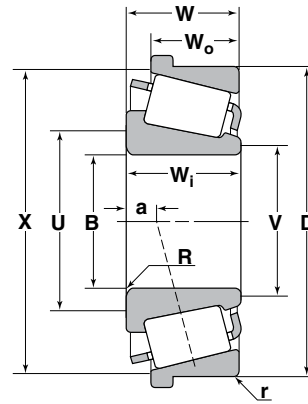

TSF Type

Basic Load Ratings		Axial Load Factor e Y_2	Cone Number	B	W_i	R	a	U	V	Cup Number	D	W_o	r	X	Z	W
Dynamic C_r	Static C_{or}			Bore Diameter	Cone Width	Maximum Shaft Fillet Radius*	Effective Load Center†	Minimum Shaft Shoulder Diameter	Minimum Shaft Shoulder Diameter		Outside Diameter	Cup Width	Maximum Housing Fillet Radius*	Maximum Housing Shoulder Diameter	Maximum Housing Shoulder Diameter	Bearing Width
lbs/N				Inch/mm						Inch/mm						
28500 127000	41500 186000	0.44 1.35	495 Series (Cont'd)													
			496AS	3.2165 81.700	1.1720 29.769	0.14 3.5	-0.03 -0.8	3.74 95.0	3.50 89.0							
			497	3.3750 85.725	1.1720 29.769	0.14 3.5	-0.03 -0.8	3.90 99.0	3.66 93.0							
			497A	3.3750 85.725	1.1720 29.769	0.25 6.4	-0.03 -0.8	4.13 105.0	3.66 93.0							
			498	3.3125 84.138	1.1720 29.769	0.14 3.5	-0.03 -0.8	3.86 98.0	3.58 91.0							
30000 133000	36500 163000	0.29 2.10	525 Series													
			525	1.5000 38.100	1.4200 36.068	0.14 3.5	-0.50 -12.7	2.13 54.0	1.89 48.0	522	4.0000 101.600	1.0625 26.988	0.13 3.3	3.74 95.0	3.50 89.0	1.3750 34.925
			526	1.6250 41.275	1.4200 36.068	0.14 3.5	-0.50 -12.7	2.24 57.0	1.97 50.0	▲522B	4.0000 101.600	1.0625 26.988	0.13 3.3	3.82 97.0	— 89.0	1.3750 34.925
			527	1.7500 44.450	1.4200 36.068	0.14 3.5	-0.50 -12.7	2.32 59.0	2.09 53.0							
			527S	1.7710 44.983	1.4200 36.068	0.17 4.3	-0.50 -12.7	2.40 61.0	2.09 53.0							
			528	1.8750 47.625	1.4200 36.068	0.14 3.5	-0.50 -12.7	2.44 62.0	2.17 55.0							
			529	2.0000 50.800	1.4200 36.068	0.03 0.8	-0.50 -12.7	2.32 59.0	2.28 58.0							
			529X	2.0000 50.800	1.4200 36.068	0.14 3.5	-0.50 -12.7	2.56 65.0	2.28 58.0							

* The maximum fillet on the shaft or in the housing that the bearing corner will clear.
 † Positive value indicates the effective load center is outside the backface of the cone.
 ▲ For additional "B" cup dimensions, see pages 173 to 174.
 ■ For parts with a "J" prefix, use metric tolerances given on page 199 and fitting practice given on page 201.
 ★ Designate bearings with hollow rollers and pinned-type retainers.
 ◆ Bearing is equipped with seals (and in some instances side rings).

Basic Load Ratings		Axial Load Factor $e Y_2$	Cone Number	B	W_i	R	a	U	V	Cup Number	D	W_o	r	X	Z	W
Dynamic C_r	Static C_{or}			Bore Diameter	Cone Width	Maximum Shaft Fillet Radius*	Effective Load Center†	Minimum Shaft Shoulder Diameter	Minimum Shaft Shoulder Diameter		Outside Diameter	Cup Width	Maximum Housing Fillet Radius*	Maximum Housing Shoulder Diameter	Maximum Housing Shoulder Diameter	Bearing Width
lbs/N				Inch/mm							Inch/mm					
31500 140000	39500 175000	0.30 2.02	535 Series													
			535	1.7500 44.450	1.4550 36.957	0.14 3.5	-0.48 -12.2	2.40 61.0	2.05 52.0	532A	4.3750 111.125	1.1875 30.162	0.13 3.3	3.94 100.0	3.74 95.0	1.5000 38.100
			536	1.8750 47.625	1.4550 36.957	0.14 3.5	-0.48 -12.2	2.56 65.0	2.17 55.0	▲ 532B	4.3750 111.125	1.1875 30.162	0.13 3.3	3.94 100.0	— —	1.5000 38.100
			537	2.0000 50.800	1.4550 36.957	0.14 3.5	-0.48 -12.2	2.56 65.0	2.32 59.0	532X	4.2500 107.950	1.1250 28.575	0.13 3.3	3.94 100.0	3.70 94.0	1.4375 36.512
			539	2.1250 53.975	1.4550 36.957	0.14 3.5	-0.48 -12.2	2.68 68.0	2.40 61.0							
			539A	2.1250 53.975	1.4550 36.957	0.22 5.6	-0.48 -12.2	2.83 72.0	2.40 61.0							
			543	1.5748 40.000	1.4550 36.957	0.14 3.5	-0.48 -12.2	2.24 57.0	1.97 50.0							
35000 156000	48000 213000	0.35 1.73	555 Series													
			554	2.4375 61.912	1.4440 36.678	0.14 3.5	-0.37 -9.4	3.03 77.0	2.80 71.0	552	4.8750 123.825	1.3125 33.338	0.13 3.3	4.57 116.0	4.29 109.0	1.5000 38.100
			555	2.0000 50.800	1.4440 36.678	0.09 2.3	-0.37 -9.4	2.60 66.0	2.44 62.0	552A	4.8750 123.825	1.1875 30.162	0.13 3.3	4.57 116.0	4.29 109.0	1.5000 38.100
			555S	2.2500 57.150	1.4440 36.678	0.14 3.5	-0.37 -9.4	2.87 73.0	2.64 67.0	▲ 552B	4.8750 123.825	1.1875 30.162	0.13 3.3	4.57 116.0	— —	1.5000 38.100
			557A	2.3750 60.325	1.4440 36.678	0.31 8.0	-0.37 -9.4	3.31 84.0	2.72 69.0	▲ 553BA	5.0000 127.000	1.3750 34.925	0.13 3.3	4.80 122.0	— —	1.4060 35.712
			557S	2.1250 53.975	1.4440 36.678	0.14 3.5	-0.37 -9.4	2.80 71.0	2.56 65.0	553X	4.8125 122.238	1.1875 30.162	0.13 3.3	4.53 115.0	4.25 108.0	1.5000 38.100
			558	2.3750 60.325	1.4440 36.678	0.09 2.3	-0.37 -9.4	2.87 73.0	2.72 69.0							
			558A	2.3750 60.325	1.4440 36.678	0.14 3.5	-0.37 -9.4	2.99 76.0	2.72 69.0							
			558S	2.3617 59.987	1.4440 36.678	0.14 3.5	-0.37 -9.4	3.03 77.0	2.72 69.0							
			559	2.5000 63.500	1.4440 36.678	0.14 3.5	-0.37 -9.4	3.07 78.0	2.83 72.0							
			560	2.6250 66.675	1.4440 36.678	0.14 3.5	-0.37 -9.4	3.19 81.0	2.95 75.0							
			560S	2.6875 68.262	1.4440 36.678	0.14 3.5	-0.37 -9.4	3.27 83.0	2.99 76.0							
36000 161000	50500 225000	0.36 1.65	565 Series													
			565	2.5000 63.500	1.4240 36.170	0.14 3.5	-0.32 -8.1	3.15 80.0	2.87 73.0	563	5.0000 127.000	1.1250 28.575	0.13 3.3	4.72 120.0	4.41 112.0	1.4375 36.512
			566	2.7500 69.850	1.4240 36.170	0.14 3.5	-0.32 -8.1	3.35 85.0	3.07 78.0	▲ 563B	5.0000 127.000	1.1250 28.575	0.13 3.3	4.76 121.0	— —	1.4375 36.512
			567	2.8750 73.025	1.4240 36.170	0.14 3.5	-0.32 -8.1	3.46 88.0	3.19 81.0							
			567A	2.8125 71.438	1.4240 36.170	0.14 3.5	-0.32 -8.1	3.39 86.0	3.15 80.0							
			567S	2.8125 71.438	1.4240 36.170	0.25 6.4	-0.32 -8.1	3.39 86.0	3.15 80.0							

* The maximum fillet on the shaft or in the housing that the bearing corner will clear.

† Positive value indicates the effective load center is outside the backface of the cone.

▲ For additional "B" cup dimensions, see pages 173 to 174.

■ For parts with a "J" prefix, use metric tolerances given on page 199 and fitting practice given on page 201.

★ Designate bearings with hollow rollers and pinned-type retainers.

◆ Bearing is equipped with seals (and in some instances side rings).

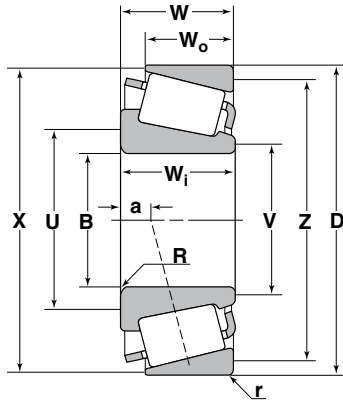

TS Type

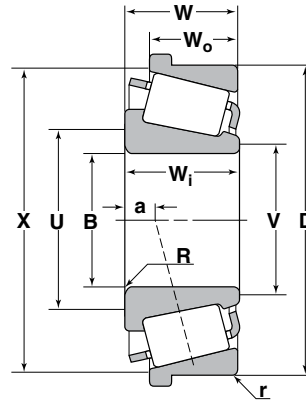

TSF Type

Basic Load Ratings		Axial Load Factor e Y_2	Cone Number	B	W_i	R	a	U	V	Cup Number	D	W_o	r	X	Z	W
Dynamic C_r	Static C_{or}			Bore Diameter	Cone Width	Maximum Shaft Fillet Radius*	Effective Load Center†	Minimum Shaft Shoulder Diameter	Minimum Shaft Shoulder Diameter		Outside Diameter	Cup Width	Maximum Housing Fillet Radius*	Maximum Housing Shoulder Diameter	Maximum Housing Shoulder Diameter	Bearing Width
lbs/N				Inch/mm						Inch/mm						
36000 161000	50500 225000	0.36 1.65	565 Series (Cont'd)													
			567XA	2.8750 73.025	1.4240 36.170	0.25 6.4	-0.32 -8.1	3.58 91.0	3.19 81.0							
			568	2.9062 73.817	1.4240 36.170	0.03 0.8	-0.32 -8.1	3.27 83.0	3.23 82.0							
			570	2.6875 68.262	1.4240 36.170	0.14 3.5	-0.32 -8.1	3.27 83.0	3.03 77.0							
38000 170000	56000 250000	0.40 1.49	575 Series													
			575	3.0000 76.200	1.4212 36.098	0.14 3.5	-0.21 -5.3	3.62 92.0	3.39 86.0	572	5.5115 139.992	1.1250 28.575	0.13 3.3	5.24 133.0	4.92 125.0	1.4375 36.512
			575S	3.0000 76.200	1.4212 36.098	0.27 6.8	-0.21 -5.3	3.90 99.0	3.39 86.0	▲ 572B	5.5115 139.992	1.1250 28.575	0.13 3.3	5.28 134.0	—	1.4375 36.512
			576	2.8750 73.025	1.4212 36.098	0.14 3.5	-0.21 -5.3	3.54 90.0	3.27 83.0							
			577	2.9375 74.612	1.4212 36.098	0.14 3.5	-0.21 -5.3	3.58 91.0	3.35 85.0							
			578	3.1490 79.985	1.4212 36.098	0.14 3.5	-0.21 -5.3	3.78 96.0	3.54 90.0							
			580	3.2500 82.550	1.4212 36.098	0.14 3.5	-0.21 -5.3	3.86 98.0	3.58 91.0							
			581	3.1875 80.962	1.4212 36.098	0.14 3.5	-0.21 -5.3	3.78 96.0	3.54 90.0							
			582	3.2500 82.550	1.4212 36.098	0.27 6.8	-0.21 -5.3	4.09 104.0	3.58 91.0							
40000 178000	61500 274000	0.44 1.36	595 Series													
			590A	3.0000 76.200	1.4300 36.322	0.14 3.5	-0.10 -2.5	3.74 95.0	3.50 89.0	592	6.0000 152.400	1.3125 33.338	0.13 3.3	5.67 144.0	5.31 135.0	1.5625 39.688
			593	3.5000 88.900	1.4300 36.322	0.14 3.5	-0.10 -2.5	4.09 104.0	3.86 98.0	592A	6.0000 152.400	1.1875 30.162	0.13 3.3	5.67 144.0	5.31 135.0	1.5625 39.688
			593A	3.5000 88.900	1.4300 36.322	0.25 6.4	-0.10 -2.5	4.33 110.0	3.86 98.0	▲ 592B	6.0000 152.400	1.1875 30.162	0.13 3.3	5.67 144.0	—	1.5625 39.688

* The maximum fillet on the shaft or in the housing that the bearing corner will clear.
 † Positive value indicates the effective load center is outside the backface of the cone.
 ▲ For additional "B" cup dimensions, see pages 173 to 174.
 ■ For parts with a "J" prefix, use metric tolerances given on page 199 and fitting practice given on page 201.
 ★ Designate bearings with hollow rollers and pinned-type retainers.
 ◆ Bearing is equipped with seals (and in some instances side rings).

Basic Load Ratings		Axial Load Factor $e Y_2$	Cone Number	B	W_j	R	a	U	V	Cup Number	D	W_o	r	X	Z	W	
Dynamic C_r	Static C_{or}			Bore Diameter	Cone Width	Maximum Shaft Fillet Radius*	Effective Load Center†	Minimum Shaft Shoulder Diameter	Minimum Shaft Shoulder Diameter		Outside Diameter	Cup Width	Maximum Housing Fillet Radius*	Maximum Housing Shoulder Diameter	Maximum Housing Shoulder Diameter	Maximum Housing Shoulder Diameter	Bearing Width
lbs/N				Inch/mm							Inch/mm						
40000 178000	61500 274000	0.44 1.36	595 Series (Cont'd)														
			593S	3.5075 89.090	1.4300 36.322	0.14 3.5	-0.10 -2.5	4.09 104.0	3.86 98.0	592XE	5.8125 147.638	1.0312 26.192	0.03 0.8	5.59 142.0	5.31 135.0	1.4062 35.713	
			594	3.7500 95.250	1.4300 36.322	0.14 3.5	-0.10 -2.5	4.33 110.0	4.09 104.0	592XS	5.8125 147.638	1.0312 26.192	0.13 3.3	5.59 142.0	5.24 133.0	1.4062 35.713	
			594A	3.7500 95.250	1.4300 36.322	0.20 5.0	-0.10 -2.5	4.45 113.0	4.09 104.0								
			594AA	3.7500 92.250	1.4300 36.322	0.03 0.8	-0.10 -2.5	3.98 101.0	3.90 99.0								
			594R	3.7500 95.250	1.4300 36.322	0.31 8.0	-0.10 -2.5	4.57 116.0	4.09 104.0								
			595	3.2500 82.550	1.4300 36.322	0.14 3.5	-0.10 -2.5	3.94 100.0	3.66 93.0								
			595A	3.1250 79.375	1.4300 36.322	0.20 5.0	-0.10 -2.5	3.86 98.0	3.58 91.0								
			596	3.3750 85.725	1.4300 36.322	0.14 3.5	-0.10 -2.5	4.02 102.0	3.78 96.0								
			597	3.6875 93.662	1.4300 36.322	0.14 3.5	-0.10 -2.5	4.37 111.0	4.02 102.0								
			597A	3.5965 91.351	1.4300 36.322	0.14 3.5	-0.10 -2.5	4.25 108.0	3.94 100.0								
			598	3.6250 92.075	1.4300 36.322	0.14 3.5	-0.10 -2.5	4.21 107.0	3.98 101.0								
			598A	3.6250 92.075	1.4300 36.322	0.25 6.4	-0.10 -2.5	4.45 113.0	3.98 101.0								
38500 171000	47500 212000	0.31 1.91	615 Series														
			615	1.7500 44.450	1.6250 41.275	0.14 3.5	-0.55 -14.0	2.44 62.0	2.20 56.0	612	4.7500 120.650	1.2500 31.750	0.13 3.3	4.33 110.0	4.13 105.0	1.6250 41.275	
			619	2.0000 50.800	1.6250 41.275	0.14 3.5	-0.55 -14.0	2.64 67.0	2.40 61.0	▲ 612B	4.7500 120.650	1.2500 31.750	0.13 3.3	4.33 110.0	—	1.6250 41.275	
			621	2.1250 53.975	1.6250 41.275	0.14 3.5	-0.55 -14.0	2.76 70.0	2.48 63.0	▲ 613B	4.7500 120.650	1.3750 34.925	0.13 3.3	4.33 110.0	—	1.6250 41.275	
			623	2.2500 57.150	1.6250 41.275	0.14 3.5	-0.55 -14.0	2.83 72.0	2.60 66.0								
			624	2.1250 53.975	1.6250 41.275	0.03 0.8	-0.55 -14.0	2.52 64.0	2.48 63.0								
43500 193000	58500 260000	0.36 1.66	635 Series														
			636	2.1250 53.975	1.6250 41.275	0.14 3.5	-0.44 -11.2	2.87 73.0	2.64 67.0	632	5.3750 136.525	1.2500 31.750	0.13 3.3	4.92 125.0	4.65 118.0	1.6250 41.275	
			639	2.5000 63.500	1.6250 41.275	0.14 3.5	-0.44 -11.2	3.19 81.0	2.91 74.0	▲ 632B	5.3750 136.525	1.2500 31.750	0.13 3.3	4.92 125.0	—	1.6250 41.275	
			641	2.6250 66.675	1.6250 41.275	0.14 3.5	-0.44 -11.2	3.27 83.0	3.03 77.0	633	5.1250 130.175	1.2500 31.750	0.13 3.3	4.88 124.0	4.57 116.0	1.6250 41.275	
			643	2.7500 69.850	1.6250 41.275	0.14 3.5	-0.44 -11.2	3.39 86.0	3.15 80.0								
			644	2.8125 71.438	1.6250 41.275	0.14 3.5	-0.44 -11.2	3.43 87.0	3.19 81.0								

* The maximum fillet on the shaft or in the housing that the bearing corner will clear.
† Positive value indicates the effective load center is outside the backface of the cone.
▲ For additional "B" cup dimensions, see pages 173 to 174.
■ For parts with a "J" prefix, use metric tolerances given on page 199 and fitting practice given on page 201.
★ Designate bearings with hollow rollers and pinned-type retainers.
◆ Bearing is equipped with seals (and in some instances side rings).

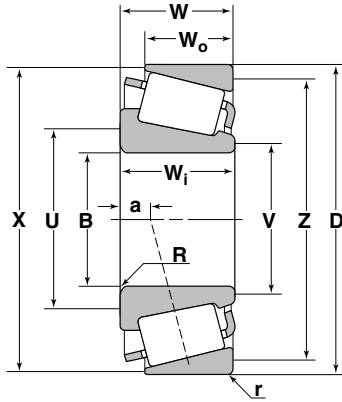

TS Type

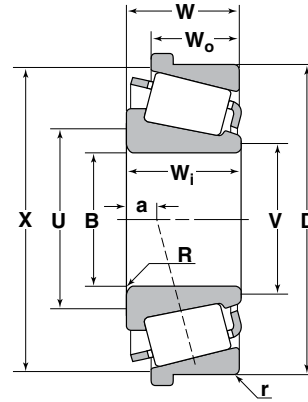

TSF Type

Basic Load Ratings		Axial Load Factor e Y_2	Cone Number	B	W_i	R	a	U	V	Cup Number	D	W_o	r	X	Z	W
Dynamic C_r	Static C_{or}			Bore Diameter	Cone Width	Maximum Shaft Fillet Radius †	Effective Load Center †	Minimum Shaft Shoulder Diameter	Minimum Shaft Shoulder Diameter		Outside Diameter	Cup Width	Maximum Housing Fillet Radius †	Maximum Housing Shoulder Diameter	Maximum Housing Shoulder Diameter	Bearing Width
lbs/N				Inch/mm						Inch/mm						
38500 171000	47500 212000	0.31 1.91	635 Series (Con't)													
			645	2.8125 71.438	1.6250 41.275	0.25 6.4	-0.44 -11.2	3.66 93.0	3.19 81.0							
46000 205000	66000 293000	0.41 1.47	655 Series													
			655	2.7500 69.850	1.6250 41.275	0.14 3.5	-0.31 -7.9	3.46 88.0	3.23 82.0	652	6.0000 152.400	1.2500 31.750	0.13 3.3	5.55 141.0	5.28 134.0	1.6250 41.275
			657	2.8750 73.025	1.6250 41.275	0.14 3.5	-0.31 -7.9	3.58 91.0	3.35 85.0	▲ 652B	6.0000 152.400	1.2500 31.750	0.13 3.3	5.55 141.0	—	1.6250 41.275
			658	2.9375 74.612	1.6250 41.275	0.14 3.5	-0.31 -7.9	3.62 92.0	3.39 86.0	653	5.7500 146.050	1.2500 31.750	0.13 3.3	5.47 139.0	5.16 131.0	1.6250 41.275
			659	3.0000 76.200	1.6250 41.275	0.14 3.5	-0.31 -7.9	3.66 93.0	3.43 87.0							
			661	3.1250 79.375	1.6250 41.275	0.14 3.5	-0.31 -7.9	3.78 96.0	3.54 90.0							
			663	3.2500 82.550	1.6250 41.275	0.14 3.5	-0.31 -7.9	3.90 99.0	3.62 92.0							
			663A	3.2500 82.550	1.6250 41.275	0.27 6.8	-0.31 -7.9	4.13 105.0	3.62 92.0							
			664	3.3125 84.138	1.6250 41.275	0.14 3.5	-0.31 -7.9	4.02 102.0	3.74 95.0							
			665	3.3750 85.725	1.6250 41.275	0.14 3.5	-0.31 -7.9	4.02 102.0	3.74 95.0							
			665A	3.3750 85.725	1.6250 41.275	0.25 6.4	-0.31 -7.9	4.21 107.0	3.74 95.0							
			662	3.1875 80.962	1.5000 38.100	0.14 3.5	-0.19 -4.7	3.90 99.0	3.62 92.0	652	6.0000 152.400	1.2500 31.750	0.13 3.3	5.55 141.0	5.28 134.0	1.5000 38.100
										▲ 652B	6.0000 152.400	1.2500 31.750	0.13 3.3	5.55 141.0	—	1.5000 38.100
										653	5.7500 146.050	1.2500 31.750	0.13 3.3	5.47 139.0	5.16 131.0	1.5000 38.100

* The maximum fillet on the shaft or in the housing that the bearing corner will clear.
 † Positive value indicates the effective load center is outside the backface of the cone.
 ▲ For additional "B" cup dimensions, see pages 173 to 174.
 ■ For parts with a "J" prefix, use metric tolerances given on page 199 and fitting practice given on page 201.
 ★ Designate bearings with hollow rollers and pinned-type retainers.
 ◆ Bearing is equipped with seals (and in some instances side rings).

Basic Load Ratings		Axial Load Factor $e Y_2$	Cone Number	B	W_i	R	a	U	V	Cup Number	D	W_o	r	X	Z	W
Dynamic C_r	Static C_{or}			Bore Diameter	Cone Width	Maximum Shaft Fillet Radius †	Effective Load Center †	Minimum Shaft Shoulder Diameter	Minimum Shaft Shoulder Diameter		Outside Diameter	Cup Width	Maximum Housing Fillet Radius †	Maximum Housing Shoulder Diameter	Maximum Housing Shoulder Diameter	Bearing Width
lbs/N				Inch/mm								Inch/mm				
50000 221000	76500 340000	0.47 1.28	675 Series							672 ▲ 672B						
			677	3.3750 85.725	1.6250 41.275	0.14 3.5	-0.11 -2.8	4.13 105.0	3.90 99.0		6.6250 168.275	1.1875 30.162	0.13 3.3	6.30 160.0	5.87 149.0	1.6250 41.275
			679	3.5000 88.900	1.6250 41.275	0.14 3.5	-0.11 -2.8	4.21 107.0	3.98 101.0		6.6250 168.275	1.1875 30.162	0.13 3.3	6.30 160.0	— —	1.6250 41.275
			681	3.6250 92.075	1.6250 41.275	0.14 3.5	-0.11 -2.8	4.33 110.0	4.09 107.0							
			681A	3.6250 92.075	1.6250 41.275	0.25 6.5	-0.11 -2.8	4.57 116.0	4.09 104.0							
			683	3.7500 95.250	1.6250 41.275	0.14 3.5	-0.11 -2.8	4.45 113.0	4.17 106.0							
			683XA	3.7500 95.250	1.6250 41.275	0.20 5.0	-0.11 -2.8	4.57 116.0	4.17 106.0							
			685	3.8750 98.425	1.6250 41.275	0.14 3.5	-0.11 -2.8	4.57 116.0	4.29 109.0							
			687	4.0000 101.600	1.6250 41.275	0.14 3.5	-0.11 -2.8	4.65 118.0	4.41 112.0							
58500 260000	81000 360000	0.33 1.84	745 Series								742 ▲ 742B					
			740	3.1875 80.962	1.8375 46.672	0.20 5.0	-0.47 -11.9	3.98 101.0	3.58 91.0	5.9090 150.089		1.4375 36.512	0.13 3.3	5.59 142.0	5.28 134.0	1.7500 44.450
			744	2.8750 73.025	1.8375 46.672	0.14 3.5	-0.47 -11.9	3.58 91.0	3.35 85.0	5.9090 150.089		1.4375 36.512	0.13 3.3	5.63 143.0	— —	1.7500 44.450
			745A	2.7500 69.850	1.8375 46.672	0.14 3.5	-0.47 -11.9	3.46 88.0	3.23 82.0							
			745S	2.5000 63.500	1.8375 46.672	0.14 3.5	-0.47 -11.9	3.15 80.0	2.83 72.0							
			748S	3.0000 76.200	1.8375 46.672	0.14 3.5	-0.47 -11.9	3.66 93.0	3.43 87.0							
			749	3.3475 85.026	1.8375 46.672	0.14 3.5	-0.47 -11.9	3.98 101.0	3.74 95.0							
			749A	3.2500 82.550	1.8375 46.672	0.14 3.5	-0.47 -11.9	3.90 99.0	3.66 93.0							
			749S	3.3475 85.026	1.8375 46.672	0.20 5.0	-0.47 -11.9	4.09 104.0	3.75 95.0							
			750	3.1250 79.375	1.8375 46.672	0.14 3.5	-0.47 -11.9	3.78 96.0	3.46 88.0							
			750A	3.2500 82.550	1.8375 46.672	0.27 6.8	-0.47 -11.9	4.17 106.0	3.66 93.0							

* The maximum fillet on the shaft or in the housing that the bearing corner will clear.
† Positive value indicates the effective load center is outside the backface of the cone.
▲ For additional "B" cup dimensions, see pages 173 to 174.
■ For parts with a "J" prefix, use metric tolerances given on page 199 and fitting practice given on page 201.
★ Designate bearings with hollow rollers and pinned-type retainers.
◆ Bearing is equipped with seals (and in some instances side rings).

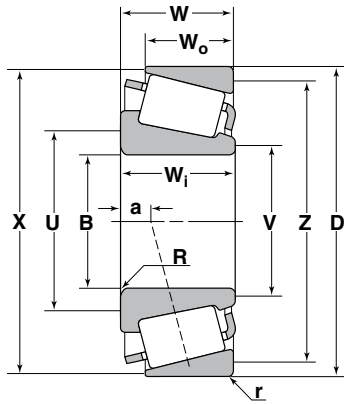

TS Type

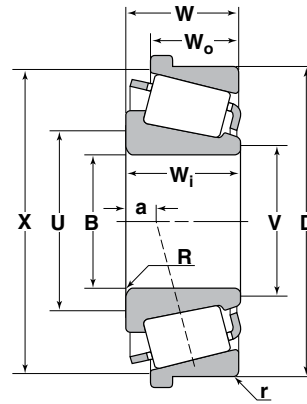

TSF Type

Basic Load Ratings		Axial Load Factor e Y_2	Cone Number	B	W_i	R	a	U	V	Cup Number	D	W_o	r	X	Z	W
Dynamic C_r	Static C_{or}			Bore Diameter	Cone Width	Maximum Shaft Fillet Radius*	Effective Load Center†	Minimum Shaft Shoulder Diameter	Minimum Shaft Shoulder Diameter		Outside Diameter	Cup Width	Maximum Housing Fillet Radius*	Maximum Housing Shoulder Diameter	Maximum Housing Shoulder Diameter	Bearing Width
lbs/N				Inch/mm						Inch/mm						
60500 269000	86000 380000	0.34 1.76	755 Series													
			755	3.0000 76.200	1.9000 48.260	0.14 3.5	-0.47 -11.9	3.74 95.0	3.46 88.0	752	6.3750 161.925	1.5000 38.100	0.13 3.3	5.91 150.0	5.67 144.0	1.8750 47.625
			756A	3.1250 79.375	1.9000 48.260	0.31 8.0	-0.47 -11.9	4.17 106.0	3.58 91.0	▲ 752B	6.3750 161.925	1.5000 38.100	0.13 3.3	5.91 150.0	—	1.8750 47.625
			757	3.2500 82.550	1.9000 48.260	0.14 3.5	-0.47 -11.9	3.94 100.0	3.70 94.0							
			758	3.3750 85.725	1.9000 48.260	0.14 3.5	-0.47 -11.9	4.06 103.0	3.82 97.0							
			759	3.5000 88.900	1.9000 48.260	0.14 3.5	-0.47 -11.9	4.17 106.0	3.90 99.0							
			760	3.5625 90.488	1.9000 48.260	0.14 3.5	-0.47 -11.9	4.21 107.0	3.98 101.0							
			762	2.8750 73.025	1.9000 48.260	0.14 3.5	-0.47 -11.9	3.62 92.0	3.82 97.0							
			766	3.5000 88.900	1.9000 48.260	0.28 7.0	-0.47 -11.9	4.45 113.0	3.90 99.0							
64000 284000	96500 430000	0.39 1.56	775 Series													
			775	3.5000 88.900	1.8900 48.006	0.19 4.8	-0.32 -8.1	4.37 111.0	3.86 98.0	772	7.1250 180.975	1.5000 38.100	0.13 3.3	6.61 168.0	6.34 161.0	1.8750 47.625
			776	3.7500 95.250	1.8900 48.006	0.14 3.5	-0.32 -8.1	4.49 114.0	4.21 107.0	▲ 772B	7.1250 180.975	1.5000 38.100	0.13 3.3	6.61 168.0	—	1.8750 47.625
			777	3.7500 95.250	1.8900 48.006	0.38 9.5	-0.32 -8.1	5.39 137.0	4.09 104.0							
			778	3.6250 92.075	1.8900 48.006	0.14 3.5	-0.32 -8.1	4.37 111.0	4.13 105.0							
			779	3.8750 98.425	1.8900 48.006	0.14 3.5	-0.32 -8.1	4.57 116.0	4.33 110.0							
			780	4.0000 101.600	1.8900 48.006	0.14 3.5	-0.32 -8.1	4.69 119.0	4.45 113.0							

* The maximum fillet on the shaft or in the housing that the bearing corner will clear.
 † Positive value indicates the effective load center is outside the backface of the cone.
 ▲ For additional "B" cup dimensions, see pages 173 to 174.
 ■ For parts with a "J" prefix, use metric tolerances given on page 199 and fitting practice given on page 201.
 ★ Designate bearings with hollow rollers and pinned-type retainers.
 ◆ Bearing is equipped with seals (and in some instances side rings).

Basic Load Ratings		Axial Load Factor $e Y_2$	Cone Number	B	W_i	R	a	U	V	Cup Number	D	W_o	r	X	Z	W
Dynamic C_r	Static C_{or}			Bore Diameter	Cone Width	Maximum Shaft Fillet Radius *	Effective Load Center †	Minimum Shaft Shoulder Diameter	Minimum Shaft Shoulder Diameter		Outside Diameter	Cup Width	Maximum Housing Fillet Radius *	Maximum Housing Shoulder Diameter	Maximum Housing Shoulder Diameter	Bearing Width
lbs/N				Inch/mm							Inch/mm					
64000 284000	96500 430000	0.39 1.56	775 Series (Con't)													
			782	4.1250 104.775	1.8900 48.006	0.14 3.5	-0.32 -8.1	4.80 122.0	4.57 116.0							
			783	3.9370 100.000	1.8900 48.006	0.14 3.5	-0.32 -8.1	4.65 118.0	4.37 111.0							
			786	4.1250 104.775	1.8900 48.006	0.25 6.4	-0.32 -8.1	5.04 128.0	4.57 116.0							
			787	4.1250 104.775	1.8900 48.006	0.28 7.0	-0.32 -8.1	5.08 129.0	4.57 116.0							
70000 310000	116000 515000	0.46 1.31	795 Series													
			795	4.7500 120.650	1.8750 47.625	0.13 3.3	-0.07 -1.8	5.47 139.0	5.28 134.0	792	8.1250 206.375	1.3750 34.925	0.13 3.3	7.80 198.0	7.32 186.0	1.8750 47.625
			797	5.1181 130.000	1.8750 47.625	0.14 3.5	-0.07 -1.8	5.83 148.0	5.55 141.0	▲ 792B	8.1250 206.375	1.3750 34.925	0.13 3.3	7.80 198.0	— —	1.8750 47.625
			798	5.0000 127.000	1.9690 50.013	0.13 3.3	-0.07 -1.8	5.63 143.0	5.35 136.0							
			799	5.0625 128.588	1.8750 47.625	0.13 3.3	-0.07 -1.8	5.75 146.0	5.51 140.0							
			799A	5.1250 130.175	1.8750 47.625	0.14 3.5	-0.07 -1.8	5.83 148.0	5.59 142.0							
76500 340000	104000 460000	0.30 2.00	835 Series													
			835	2.7500 69.850	2.2190 56.363	0.14 3.5	-0.73 -18.5	3.58 91.0	3.31 84.0	832	6.6250 168.275	1.6250 41.275	0.13 3.3	6.10 155.0	5.87 149.0	2.1250 53.975
			837	3.0000 76.200	2.2190 56.363	0.03 0.8	-0.73 -18.5	3.23 82.0	3.35 85.0	▲ 832B	6.6250 168.275	1.6250 41.275	0.13 3.3	6.10 155.0	— —	2.1250 53.975
			839	3.2500 82.550	2.2190 56.363	0.03 0.8	-0.73 -18.5	3.46 88.0	3.58 91.0							
			841	3.3750 85.725	2.2190 56.363	0.14 3.5	-0.73 -18.5	4.09 104.0	3.82 97.0							
			842	3.2500 82.550	2.2190 56.363	0.14 3.5	-0.73 -18.5	3.98 101.0	3.70 94.0							
			843	3.0000 76.200	2.2190 56.363	0.25 3.5	-0.73 -18.5	3.98 101.0	3.50 89.0							
			850	3.5000 88.900	2.2190 56.363	0.14 3.5	-0.73 -18.5	4.17 106.0	3.94 100.0							

* The maximum fillet on the shaft or in the housing that the bearing corner will clear.
 † Positive value indicates the effective load center is outside the backface of the cone.
 ▲ For additional "B" cup dimensions, see pages 173 to 174.
 ■ For parts with a "J" prefix, use metric tolerances given on page 199 and fitting practice given on page 201.
 ★ Designate bearings with hollow rollers and pinned-type retainers.
 ◆ Bearing is equipped with seals (and in some instances side rings).

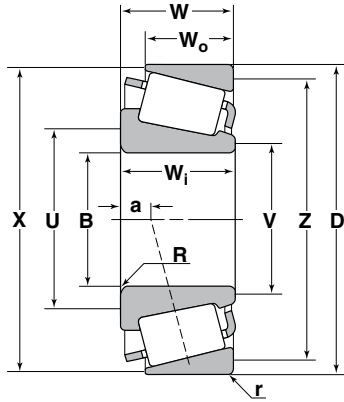

TS Type

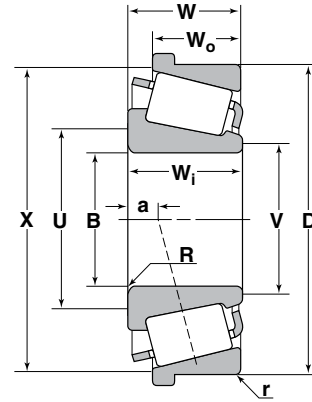

TSF Type

Basic Load Ratings		Axial Load Factor e Y_2	Cone Number	B	W_i	R	a	U	V	Cup Number	D	W_o	r	X	Z	W
Dynamic C_r	Static C_{or}			Bore Diameter	Cone Width	Maximum Shaft Fillet Radius*	Effective Load Center†	Minimum Shaft Shoulder Diameter	Minimum Shaft Shoulder Diameter		Outside Diameter	Cup Width	Maximum Housing Fillet Radius*	Maximum Housing Shoulder Diameter	Maximum Housing Shoulder Diameter	Bearing Width
lbs/N				Inch/mm						Inch/mm						
85500 380000	125000 555000	0.33 1.79	855 Series							854 ▲ 854B						
			855	3.5000 88.900	2.2650 57.531	0.31 8.0	-0.60 -15.2	4.65 118.0	4.06 103.0		7.5000 190.500	1.7500 44.450	0.13 3.3	6.85 174.0	6.69 170.0	2.2500 57.150
			857	3.6250 92.075	2.2650 57.531	0.31 8.0	-0.60 -15.2	4.76 121.0	4.17 106.0		7.5000 190.500	1.7500 44.450	0.13 3.3	6.85 174.0	—	2.2500 57.150
			860	4.0000 101.600	2.2650 57.531	0.38 9.7	-0.60 -15.2	5.63 143.0	4.29 109.0							
			861	4.0000 101.600	2.2650 57.531	0.31 8.0	-0.60 -15.2	5.08 129.0	4.49 114.0							
			864	3.7500 95.250	2.2650 57.531	0.31 8.0	-0.60 -15.2	4.84 123.0	4.25 108.0							
			866	3.8750 98.425	2.2650 57.531	0.14 3.5	-0.60 -15.2	4.65 118.0	4.37 111.0							
			869	3.4375 87.312	2.2650 57.531	0.31 8.0	-0.60 -15.2	4.80 122.0	3.74 95.0							
98000 435000	162000 720000	0.42 1.43	895 Series							892 ▲ 892B						
			896	5.3750 136.525	2.2500 57.150	0.14 3.5	-0.24 -6.1	6.14 156.0	5.91 150.0		9.0000 228.600	1.7500 44.450	0.13 3.3	8.50 216.0	8.07 205.0	2.2500 57.150
			898	5.5000 139.700	2.2500 57.150	0.14 3.5	-0.24 -6.1	6.30 160.0	6.02 153.0		9.0000 228.600	1.7500 44.450	0.13 3.3	8.50 216.0	—	2.2500 57.150
			898A	5.5000 139.700	2.2500 57.150	0.25 6.5	-0.24 -6.1	6.50 165.0	6.02 153.0							

* The maximum fillet on the shaft or in the housing that the bearing corner will clear.
 † Positive value indicates the effective load center is outside the backface of the cone.
 ▲ For additional "B" cup dimensions, see pages 173 to 174.
 ■ For parts with a "J" prefix, use metric tolerances given on page 199 and fitting practice given on page 201.
 ★ Designate bearings with hollow rollers and pinned-type retainers.
 ◆ Bearing is equipped with seals (and in some instances side rings).

Basic Load Ratings		Axial Load Factor $e Y_2$	Cone Number	B	W_i	R	a	U	V	Cup Number	D	W_o	r	X	Z	W
Dynamic C_r	Static C_{or}			Bore Diameter	Cone Width	Maximum Shaft Fillet Radius †	Effective Load Center †	Minimum Shaft Shoulder Diameter	Minimum Shaft Shoulder Diameter		Outside Diameter	Cup Width	Maximum Housing Fillet Radius *	Maximum Housing Shoulder Diameter	Maximum Housing Shoulder Diameter	Bearing Width
lbs/N				Inch/mm								Inch/mm				
104000 460000	151000 670000	0.33 1.84	935 Series													
			936	4.2500 107.950	2.6250 66.675	0.31 8.0	-0.78 -19.8	5.39 137.0	4.80 122.0	930	8.1250 206.375	2.1250 53.975	0.13 3.3	7.60 193.0	7.36 187.0	2.6250 66.675
			938	4.5000 114.300	2.6250 66.675	0.28 7.0	-0.78 -19.8	5.55 141.0	5.04 128.0	932	8.3750 212.725	2.1250 53.975	0.13 3.3	7.60 193.0	7.36 187.0	2.6250 66.675
			938A	4.5000 114.300	2.6250 66.675	0.13 3.2	-0.78 -19.8	5.12 130.0	4.84 123.0	▲ 932B	8.3750 212.725	2.1250 53.975	0.13 3.3	7.83 199.0	— —	2.6250 66.675
			941	4.0000 101.600	2.6250 66.675	0.28 7.0	-0.78 -19.8	5.12 130.0	4.61 117.0							
			943	3.8750 98.425	2.6250 66.675	0.14 3.5	-0.78 -19.8	4.53 115.0	4.21 107.0							
22100 98000	29000 129000	0.34 1.77	3700 Series													
			3767	2.0625 52.388	1.1930 30.302	0.09 2.3	-0.32 -8.1	2.48 63.0	2.32 59.0	3720	3.6718 93.264	0.9375 23.812	0.13 3.3	3.46 88.0	3.23 82.0	1.1875 30.162
			3767A	2.0625 52.388	1.1930 30.302	0.09 2.3	-0.32 -8.1	2.48 63.0	2.32 59.0	▲ 3720B	3.6718 93.264	0.9375 23.812	0.13 3.3	3.54 90.0	— —	1.1875 30.162
			3774	1.5625 39.688	1.1930 30.302	0.14 3.5	-0.32 -8.1	2.24 57.0	1.85 47.0	3726	3.7500 95.250	0.9375 23.812	0.13 3.3	3.50 89.0	3.27 83.0	1.1875 30.162
			3775	2.0000 50.800	1.1930 30.302	0.03 0.0	-0.32 -8.1	2.28 58.0	2.28 58.0	3730	3.6718 93.264	0.9375 23.812	0.03 0.8	3.46 88.0	3.31 84.0	1.1875 30.162
			3776	1.7710 44.983	1.1930 30.302	0.14 3.5	-0.32 -8.1	2.32 59.0	2.09 53.0	3732	3.8750 98.425	0.9375 23.812	0.13 3.3	3.54 90.0	3.31 84.0	1.1875 30.162
			3777	1.8125 46.038	1.1930 30.302	0.14 3.5	-0.32 -8.1	2.36 60.0	2.09 53.0	3733	3.9385 100.038	0.9375 23.812	0.03 0.8	3.58 91.0	3.74 95.0	1.1875 30.162
			3778	1.8750 47.625	1.1930 30.302	0.25 6.4	-0.32 -8.1	2.64 67.0	2.17 55.0	3735	3.9386 100.040	0.9375 23.812	0.13 3.3	3.58 91.0	3.31 84.0	1.1850 30.100
			3779	1.8750 47.625	1.1930 30.302	0.14 3.5	-0.32 -8.1	2.40 61.0	2.17 55.0							
			3780	2.0000 50.800	1.1930 30.302	0.14 3.5	-0.32 -8.1	2.52 64.0	2.28 58.0							
			3781	1.9375 49.212	1.1930 30.302	0.14 3.5	-0.32 -8.1	2.44 62.0	2.20 56.0							
			3781A	1.9060 48.412	1.1930 30.302	0.14 3.5	-0.32 -8.1	2.56 65.0	2.20 56.0							
			3782	1.7500 44.450	1.1930 30.302	0.14 3.5	-0.32 -8.1	2.28 58.0	2.05 52.0							
			3783	1.75000 44.450	1.1930 30.302	0.25 6.4	-0.32 -8.1	2.51 63.8	2.05 52.0							
			3784	2.0000 50.800	1.1930 30.302	0.25 6.4	-0.32 -8.1	2.76 70.0	2.28 58.0							
			3795	2.0000 50.800	1.1930 30.302	0.14 3.5	-0.32 -8.1	2.68 68.0	2.28 58.0							

* The maximum fillet on the shaft or in the housing that the bearing corner will clear.
† Positive value indicates the effective load center is outside the backface of the cone.
▲ For additional "B" cup dimensions, see pages 173 to 174.
■ For parts with a "J" prefix, use metric tolerances given on page 199 and fitting practice given on page 201.
★ Designate bearings with hollow rollers and pinned-type retainers.
◆ Bearing is equipped with seals (and in some instances side rings).

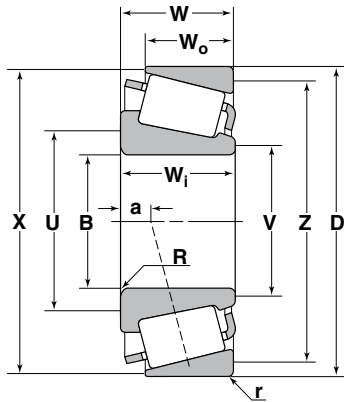

TS Type

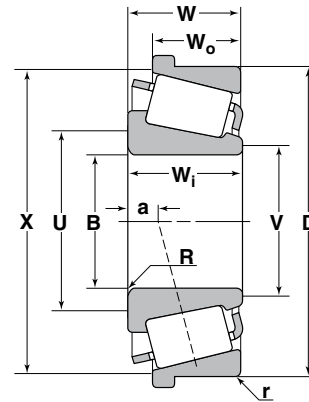

TSF Type

Basic Load Ratings		Axial Load Factor e Y_2	Cone Number	B	W_i	R	a	U	V	Cup Number	D	W_o	r	X	Z	W
Dynamic C_r	Static C_{or}			Bore Diameter	Cone Width	Maximum Shaft Fillet Radius*	Effective Load Center†	Minimum Shaft Shoulder Diameter	Minimum Shaft Shoulder Diameter		Outside Diameter	Cup Width	Maximum Housing Fillet Radius*	Maximum Housing Shoulder Diameter	Maximum Housing Shoulder Diameter	Bearing Width
lbs/N				Inch/mm						Inch/mm						
25300 113000	36500 163000	0.40 1.49	3900 Series													
			3975	2.0000 50.800	1.1830 30.048	0.14 3.5	-0.18 -4.6	2.68 68.0	2.40 61.0	3920	4.4375 112.712	0.9375 23.812	0.13 3.3	4.17 106.0	3.90 99.0	1.1875 30.162
			3977	2.3622 60.000	1.1830 30.048	0.14 3.5	-0.18 -4.6	2.91 74.0	2.68 68.0	▲ 3920B	4.4375 112.712	0.9375 23.812	0.13 3.3	4.25 108.0	—	1.1875 30.162
			3979	2.2500 57.150	1.1830 30.048	0.14 3.5	-0.18 -4.6	2.83 72.0	2.60 66.0	3921XA	4.3301 109.985	0.9375 23.812	0.02 0.5	4.12 105.0	3.94 100.0	1.1713 29.750
			3980	2.3750 60.325	1.1830 30.048	0.14 3.5	-0.18 -4.6	2.95 75.0	2.68 68.0	3925	4.4375 112.712	0.9375 23.812	0.03 0.8	4.17 106.0	3.98 101.0	1.1875 30.162
			3981	2.3125 58.738	1.1830 30.048	0.14 3.5	-0.18 -4.6	2.91 74.0	2.68 66.0	3926	4.4375 112.712	1.0625 29.988	0.13 3.3	4.17 106.0	3.86 98.0	1.3125 33.338
			3982	2.5000 63.500	1.1830 30.048	0.14 3.5	-0.18 -4.6	3.03 77.0	2.80 71.0							
			3984	2.6250 66.675	1.1830 30.048	0.14 3.5	-0.18 -4.6	3.15 80.0	2.91 74.0							
			3994	2.6250 66.675	1.1830 30.048	0.22 5.6	-0.18 -4.6	3.31 84.0	2.91 74.0							
33000 147000	46000 204000	0.34 1.79	4500 Series													
			4559	1.7717 45.000	1.5810 40.157	0.14 3.5	-0.49 -12.4	2.44 62.0	2.09 53.0	4520	3.9843 101.200	1.3125 33.338	0.13 3.3	3.78 96.0	3.35 85.0	1.5625 39.687
			4580	2.0000 50.800	1.5810 40.157	0.14 3.5	-0.49 -12.4	2.68 68.0	2.28 58.0	4535	4.1250 104.775	1.3125 33.338	0.13 3.3	3.90 99.0	3.54 90.0	1.5625 39.687
			4595	2.1250 53.975	1.5810 40.157	0.14 3.5	-0.49 -12.4	2.76 70.0	2.48 63.0	4536	4.3750 111.125	1.2813 32.545	0.13 3.3	4.17 106.0	3.74 95.0	1.5313 38.895
			4553	2.1250 53.975	1.8310 46.507	0.14 3.5	-0.49 -12.4	2.76 70.0	2.48 63.0	4520	3.9843 101.200	1.3125 33.338	0.13 3.3	3.78 96.0	3.35 85.0	1.8125 46.037
										4535	4.1250 104.775	1.3125 33.338	0.13 3.3	3.90 99.0	3.54 90.0	1.8125 46.037
										4536	4.3750 111.125	1.2813 32.545	0.13 3.3	4.17 106.0	3.74 95.0	1.7813 45.245

* The maximum fillet on the shaft or in the housing that the bearing corner will clear.
 † Positive value indicates the effective load center is outside the backface of the cone.
 ▲ For additional "B" cup dimensions, see pages 173 to 174.
 ■ For parts with a "J" prefix, use metric tolerances given on page 199 and fitting practice given on page 201.
 ★ Designate bearings with hollow rollers and pinned-type retainers.
 ♦ Bearing is equipped with seals (and in some instances side rings).

Basic Load Ratings		Axial Load Factor $e Y_2$	Cone Number	B	W_i	R	a	U	V	Cup Number	D	W_o	r	X	Z	W
Dynamic C_r	Static C_{or}			Bore Diameter	Cone Width	Maximum Shaft Fillet Radius*	Effective Load Center†	Minimum Shaft Shoulder Diameter	Minimum Shaft Shoulder Diameter		Outside Diameter	Cup Width	Maximum Housing Fillet Radius*	Maximum Housing Shoulder Diameter	Maximum Housing Shoulder Diameter	Bearing Width
lbs/N				Inch/mm								Inch/mm				
38500 171000	51500 229000	0.30 2.02	5300 Series													
			5356	1.7500 44.450	1.7510 44.475	0.05 1.3	-0.63 -16.0	2.28 58.0	2.20 56.0	5335	4.0625 103.188	1.4375 36.512	0.13 3.3	3.82 97.0	3.50 89.0	1.7188 43.658
			5358	1.8750 47.625	1.7510 44.475	0.05 1.3	-0.63 -16.0	2.17 55.0	2.20 56.0							
			5395	1.9375 49.212	1.7510 44.475	0.14 3.5	-0.63 -16.0	2.60 66.0	2.36 60.0							
42500 190000	63000 280000	0.36 1.67	5500 Series													
			5557	2.6875 68.262	1.7230 43.764	0.14 3.5	-0.48 -12.2	3.35 85.0	3.03 77.0	5520	4.7343 120.250	1.4375 36.512	0.13 3.3	4.57 116.0	4.17 106.0	1.7500 44.450
			5565	2.0000 50.800	1.7230 43.764	0.05 1.3	-0.48 -12.2	2.64 67.0	2.56 65.0	5521	5.1181 130.000	1.4375 36.512	0.13 3.3	4.92 125.0	4.49 114.0	1.7500 44.450
			5577	2.1250 53.975	1.7230 43.764	0.05 1.3	-0.48 -12.2	2.64 67.0	2.56 65.0	5535	4.8125 122.238	1.4375 36.512	0.13 3.3	4.57 116.0	4.17 106.0	1.7188 43.658
			5578	2.1250 53.975	1.7230 43.764	0.14 3.5	-0.48 -12.2	2.87 73.0	2.64 67.0							
			5582	2.3750 60.325	1.7230 43.764	0.03 0.8	-0.48 -12.2	2.60 66.0	2.72 69.0							
			5583	2.3750 60.325	1.7230 43.764	0.14 3.5	-0.48 -12.2	3.07 78.0	2.83 72.0							
			5584	2.5000 63.500	1.7230 43.764	0.14 3.5	-0.48 -12.2	3.19 81.0	2.95 75.0							
			5595	2.5938 65.883	1.7230 43.764	0.14 3.5	-0.48 -12.2	3.27 83.0	3.03 77.0							
46500 207000	73500 330000	0.41 1.48	5700 Series													
			5760	3.0000 76.200	1.8150 46.100	0.14 3.5	-0.46 -11.7	3.70 94.0	3.46 88.0	5735	5.3438 135.733	1.3750 34.925	0.13 3.3	5.12 130.0	4.69 119.0	1.7500 44.450
			5795	3.0625 77.788	1.8150 46.100	0.14 3.5	-0.46 -11.7	3.74 95.0	3.43 87.0							
53000 236000	67000 298000	0.30 2.01	6200 Series													
			6277	1.7500 44.450	2.0625 52.388	0.14 3.5	-0.77 -19.6	2.64 67.0	2.36 60.0	6220	5.0000 127.000	1.6250 41.275	0.13 3.3	4.61 117.0	4.25 108.0	2.0000 50.800
			6280	2.1250 53.975	2.0625 52.388	0.14 3.5	-0.77 -19.6	2.91 74.0	2.64 67.0							

* The maximum fillet on the shaft or in the housing that the bearing corner will clear.
† Positive value indicates the effective load center is outside the backface of the cone.
▲ For additional "B" cup dimensions, see pages 173 to 174.
■ For parts with a "J" prefix, use metric tolerances given on page 199 and fitting practice given on page 201.
★ Designate bearings with hollow rollers and pinned-type retainers.
◆ Bearing is equipped with seals (and in some instances side rings).

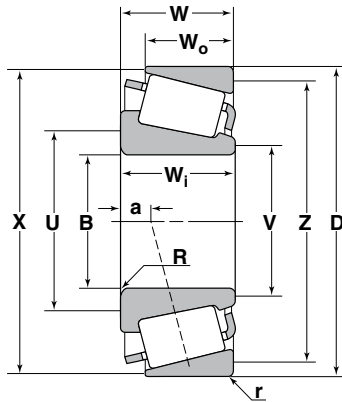

TS Type

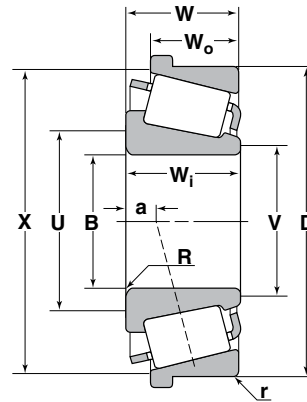

TSF Type

Basic Load Ratings		Axial Load Factor e Y_2	Cone Number	B	W_i	R	a	U	V	Cup Number	D	W_o	r	X	Z	W
Dynamic C_r	Static C_{or}			Bore Diameter	Cone Width	Maximum Shaft Fillet Radius [†]	Effective Load Center [†]	Minimum Shaft Shoulder Diameter	Minimum Shaft Shoulder Diameter		Outside Diameter	Cup Width	Maximum Housing Fillet Radius [†]	Maximum Housing Shoulder Diameter	Maximum Housing Shoulder Diameter	Bearing Width
lbs/N				Inch/mm						Inch/mm						
59000 262000	79000 350000	0.32 1.85	6300 Series													
			6376	2.3750 60.325	2.2050 56.007	0.14 3.5	-0.76 -19.3	3.03 77.0	2.72 69.0	6320	5.3447 135.755	1.7500 44.450	0.13 3.3	4.96 126.0	4.61 117.0	2.1250 53.975
			6379	2.5625 65.088	2.2050 56.007	0.14 3.5	-0.76 -19.3	3.31 84.0	3.03 77.0	■ J6327	5.5118 140.000	1.7500 44.450	0.13 3.3	5.35 136.0	4.69 119.0	2.1250 53.975
			6381	2.1649 54.988	2.2050 56.007	0.14 3.5	-0.76 -19.3	2.99 76.0	2.76 70.0	6321	5.1875 131.762	1.7500 44.450	0.13 3.3	4.80 122.0	4.45 113.0	2.1250 53.975
			6382	2.5000 63.500	2.2050 56.007	0.17 4.3	-0.76 -19.3	3.31 84.0	3.03 77.0							
			6386	2.6250 66.675	2.2050 56.007	0.17 4.3	-0.76 -19.3	3.43 87.0	3.03 77.0							
			6386A	2.6250 66.675	2.2050 56.007	0.34 8.7	-0.76 -19.3	3.73 94.7	3.03 77.0							
			6389	2.6250 66.675	2.2050 56.007	0.25 6.4	-0.76 -19.3	3.58 91.0	3.03 77.0							
			6391	2.3617 59.987	2.2050 56.007	0.14 3.5	-0.76 -19.3	3.03 77.0	2.72 69.0							
			■ J6392	2.5591 65.000	2.2050 56.007	0.12 3.0	-0.76 -19.3	3.27 83.0	3.03 77.0							
64000 285000	91000 405000	0.36 1.66	6400 Series													
			6454	2.7500 69.850	2.1350 54.229	0.20 5.0	-0.59 -15.0	3.66 93.0	3.11 79.0	6420	5.8750 149.225	1.7500 44.450	0.13 3.3	5.51 140.0	5.08 129.0	2.1250 53.975
			6455	2.2500 57.150	2.1350 54.229	0.14 3.5	-0.59 -15.0	2.91 74.0	2.60 66.0	▲ 6420B	5.8750 149.225	1.7500 44.450	0.13 3.3	5.51 140.0	—	2.1250 53.975
			6460	2.8750 73.025	2.1350 54.229	0.14 3.5	-0.59 -15.0	3.66 93.0	3.34 87.0	6425	6.0000 152.400	1.7500 44.450	0.13 3.3	5.51 140.0	5.08 129.0	2.1250 53.975
			6461	3.0000 76.200	2.1350 54.229	0.14 3.5	-0.59 -15.0	3.78 96.0	3.52 89.0							
			6461A	3.0000 76.200	2.1350 54.229	0.38 9.7	-0.59 -15.0	4.25 108.0	3.52 89.0							

* The maximum fillet on the shaft or in the housing that the bearing corner will clear.
 † Positive value indicates the effective load center is outside the backface of the cone.
 ▲ For additional "B" cup dimensions, see pages 173 to 174.
 ■ For parts with a "J" prefix, use metric tolerances given on page 199 and fitting practice given on page 201.
 ★ Designate bearings with hollow rollers and pinned-type retainers.
 ◆ Bearing is equipped with seals (and in some instances side rings).

Basic Load Ratings		Axial Load Factor $e Y_2$	Cone Number	B	W_i	R	a	U	V	Cup Number	D	W_o	r	X	Z	W	
Dynamic C_r	Static C_{or}			Bore Diameter	Cone Width	Maximum Shaft Fillet Radius*	Effective Load Center†	Minimum Shaft Shoulder Diameter	Minimum Shaft Shoulder Diameter		Outside Diameter	Cup Width	Maximum Housing Fillet Radius*	Maximum Housing Shoulder Diameter	Maximum Housing Shoulder Diameter	Maximum Housing Shoulder Diameter	Bearing Width
lbs/N				Inch/mm								Inch/mm					
64000 285000	91000 405000	0.36 1.66	6400 Series (Cont'd)														
			6464	2.5575 64.960	2.1350 54.229	0.14 3.5	-0.59 -15.0	3.38 85.9	3.23 82.0								
			6466	3.0000 76.200	2.1350 54.229	0.25 6.4	-0.59 -15.0	3.96 100.6	3.49 88.6								
68500 305000	103000 460000	0.40 1.50	6500 Series														
			6553	3.3750 85.725	2.1693 55.100	0.27 6.9	-0.52 -13.2	4.57 116.0	3.74 95.0	6535	6.3750 161.925	1.6875 42.862	0.13 3.3	6.06 154.0	5.55 141.0	2.1250 53.975	
			6559C	3.2500 82.550	2.1693 55.100	0.14 3.5	-0.52 -13.2	4.09 104.0	3.86 98.0	▲ 6535B	6.3750 161.925	1.6875 42.862	0.13 3.3	6.10 155.0	—	2.1250 53.975	
			6574	2.9985 76.162	2.1693 55.100	0.14 3.5	-0.52 -13.2	3.66 93.0	3.35 85.0	6536	6.3750 161.925	1.6875 42.862	0.03 0.8	6.06 154.0	5.67 144.0	2.1250 53.975	
			6575	3.0000 76.200	2.1693 55.100	0.25 6.4	-0.52 -13.2	4.09 104.0	3.62 92.0								
			6576	3.0000 76.200	2.1693 55.100	0.14 3.5	-0.52 -13.2	3.90 99.0	3.62 92.0								
			6580	3.5000 88.900	2.1693 55.100	0.14 3.5	-0.52 -13.2	4.29 109.0	4.01 102.0								
51000 227000	70500 315000	0.33 1.80	JF7000 Series														
			■ JF7049	2.7559 70.000	1.6535 42.000	0.12 3.0	-0.49 -12.4	3.39 86.0	3.17 81.0	■ JF7010	5.1181 130.000	1.3780 35.000	0.10 2.5	4.88 124.0	4.57 116.0	1.6929 43.000	
			■ JF7049A	2.7559 70.000	1.6535 42.000	0.28 7.0	-0.49 -12.4	3.70 94.0	3.17 81.0								
104000 465000	208000 925000	0.41 1.48	8500 Series														
			8573	9.0000 228.600	2.0625 52.388	0.25 6.4	0.30 7.6	10.04 255.0	9.61 244.0	8520	12.8750 327.025	1.4375 36.512	0.13 3.3	12.32 313.0	12.01 305.0	2.0625 52.388	
			8575	9.2500 234.950	2.0625 52.388	0.25 6.4	0.30 7.6	10.20 259.0	9.76 248.0	▲ 8520B	12.8750 327.025	1.4375 36.512	0.13 3.3	12.32 313.0	—	2.0625 52.388	
			8578	9.5000 241.300	2.0625 52.388	0.25 6.4	0.30 7.6	10.39 264.0	9.96 253.0								
52500 235000	59500 264000	0.66 0.91	9100 Series														
			9181	2.4375 61.912	1.8125 46.038	0.03 0.8	-0.15 -3.8	2.64 67.0	2.80 71.0	9121	6.0000 152.400	1.2500 31.750	0.13 3.3	5.71 145.0	5.12 130.0	1.8750 47.625	
			9185	2.6875 68.262	1.8125 46.038	0.14 3.5	-0.15 -3.8	3.70 94.0	3.20 81.0								
55000 245000	64500 286000	0.71 0.85	9200 Series														
			9285	3.0000 76.200	1.8125 46.038	0.14 3.5	0.00 0.0	4.06 103.0	3.56 90.0	9220	6.3750 161.925	1.2500 31.750	0.13 3.3	6.03 153.0	5.43 138.0	1.9375 49.212	
57000 255000	69000 310000	0.76 0.79	9300 Series														
			9380	3.0000 76.200	1.8125 46.038	0.14 3.5	0.17 4.3	4.13 105.0	3.87 98.0	9320	7.0000 177.800	1.2500 31.750	0.13 3.3	6.81 173.0	6.38 162.0	2.0625 52.387	
			9385	2.0000 50.800	1.8125 46.038	0.14 3.5	0.17 4.3	4.37 111.0	3.87 98.0	9321	6.7500 171.450	1.2500 31.750	0.13 3.3	6.46 153.0	5.79 138.0	1.9375 49.212	

* The maximum fillet on the shaft or in the housing that the bearing corner will clear.
 † Positive value indicates the effective load center is outside the backface of the cone.
 ▲ For additional "B" cup dimensions, see pages 173 to 174.
 ■ For parts with a "J" prefix, use metric tolerances given on page 199 and fitting practice given on page 201.
 ★ Designate bearings with hollow rollers and pinned-type retainers.
 ◆ Bearing is equipped with seals (and in some instances side rings).

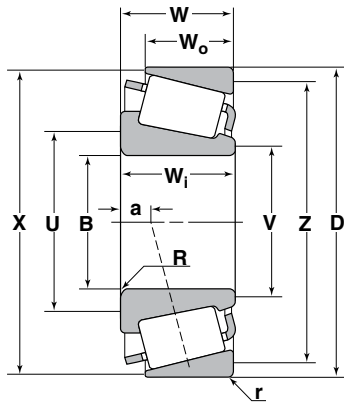

TS Type

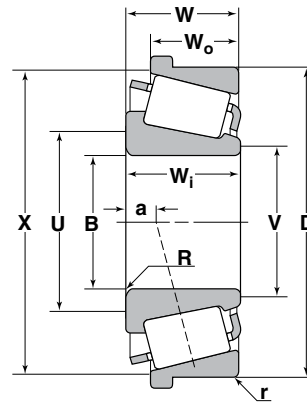

TSF Type

Basic Load Ratings		Axial Load Factor e Y_2	Cone Number	B	W_i	R	a	U	V	Cup Number	D	W_o	r	X	Z	W
Dynamic C_r	Static C_{or}			Bore Diameter	Cone Width	Maximum Shaft Fillet Radius*	Effective Load Center†	Minimum Shaft Shoulder Diameter	Minimum Shaft Shoulder Diameter		Outside Diameter	Cup Width	Maximum Housing Fillet Radius*	Minimum Housing Shoulder Diameter	Maximum Housing Shoulder Diameter	Bearing Width
lbs/N				Inch/mm									Inch/mm			
57000 255000	69000 310000	0.76 0.79	9300 Series (Cont'd)							▲ 9321B	6.7500 171.450	1.2500 31.750	0.13 3.3	6.46 153.0	— —	1.9375 49.212
			9378	3.0000 76.200	2.0000 50.800	0.14 3.5	0.36 9.1	4.13 105.0	3.87 98.0	9320	7.0000 177.800	1.2500 31.750	0.13 3.3	6.81 173.0	6.38 162.0	2.1875 55.562
										9321	6.7500 171.450	1.2500 31.750	0.13 3.3	6.46 153.0	5.79 138.0	2.0625 52.387
										▲ 9321B	6.7500 161.925	1.2500 31.750	0.13 3.3	6.46 153.0	— —	2.0625 52.387
23900 106000	34000 151000	0.47 1.27	JP10000 Series							■ JP10010	5.7087 145.000	0.6890 17.500	0.12 3.0	5.51 140.0	5.28 134.0	0.9449 24.000
			■ JP10044	3.7402 95.000	0.8858 22.500	0.12 3.0	0.24 6.1	4.25 108.0	4.02 102.0	■ JP10010B	5.7087 145.000	0.6890 17.500	0.12 3.0	5.87 149.0	— —	0.9449 24.000
			■ JP10049	3.9370 100.000	0.8858 22.500	0.12 3.0	0.24 6.1	4.53 115.0	4.25 108.0							
42000 188000	67500 300000	0.50 1.19	JP14000 Series							■ JP14010	7.6772 195.000	.8268 21.000	0.12 3.0	7.44 189.0	7.17 182.0	1.1417 29.00
			■ JP14049	5.5118 140.000	1.0630 27.000	0.12 3.0	0.46 11.6	6.02 153.0	5.83 148.0							
22100 98500	35000 156000	0.42 1.44	27600 Series							27620	4.9375 125.412	0.7813 19.845	0.06 1.5	4.72 120.0	4.53 115.0	1.0000 25.400
			27680	2.8750 73.025	1.0000 25.400	0.14 3.5	0.02 0.5	3.54 90.0	3.19 81.0	▲ 27620B	4.9375 125.412	0.7813 19.845	0.06 1.5	4.84 123.0	— —	1.0000 25.400
			27684	3.0000 76.200	1.0000 25.400	0.14 3.5	0.02 0.5	3.58 91.0	3.31 84.0							
			27687	3.2500 82.550	1.0000 25.400	0.14 3.5	0.02 0.5	3.78 96.0	3.50 89.0							
			27689	3.2813 83.345	1.0000 25.400	0.03 0.8	0.02 0.5	3.54 90.0	3.54 90.0							
			27690	3.2813 83.345	1.0000 25.400	0.14 3.5	0.02 0.5	3.78 96.0	3.54 90.0							
			27691	3.2813 83.345	1.0000 25.400	0.25 6.4	0.02 0.5	4.02 102.0	3.54 90.0							
			27695	3.3455 84.976	1.0000 25.400	0.20 5.0	0.02 0.5	4.25 108.0	3.66 93.0							

* The maximum fillet on the shaft or in the housing that the bearing corner will clear.
 † Positive value indicates the effective load center is outside the backface of the cone.
 ▲ For additional "B" cup dimensions, see pages 173 to 174.
 ■ For parts with a "J" prefix, use metric tolerances given on page 199 and fitting practice given on page 201.
 ★ Designate bearings with hollow rollers and pinned-type retainers.
 ♦ Bearing is equipped with seals (and in some instances side rings).

Basic Load Ratings		Axial Load Factor e Y ₂	Cone Number	B	W _i	R	a	U	V	Cup Number	D	W _o	r	X	Z	W
Dynamic C _r	Static C _{or}			Bore Diameter	Cone Width	Maximum Shaft Fillet Radius †	Effective Load Center †	Minimum Shaft Shoulder Diameter	Minimum Shaft Shoulder Diameter		Outside Diameter	Cup Width	Maximum Housing Fillet Radius †	Maximum Housing Shoulder Diameter	Maximum Housing Shoulder Diameter	Bearing Width
lbs/N				Inch/mm									Inch/mm			
20500 91500	31000 138000	0.46 1.31	29500 Series													
			29580	2.3622 60.000	1.0000 25.400	0.14 3.5	-0.03 -0.8	2.95 75.0	2.68 68.0	29520	4.2500 107.950	0.7500 19.050	0.13 3.3	4.06 103.0	3.78 96.0	1.0000 25.400
			29582	2.3622 60.000	1.0000 25.400	0.03 0.8	-0.03 -0.8	2.72 69.0	2.68 68.0	▲ 29520B	4.2500 107.950	0.7500 19.050	0.13 3.3	4.13 105.0	—	1.0000 25.400
			29585	2.5000 63.500	1.0000 25.400	0.14 3.5	-0.03 -0.8	3.03 77.0	2.80 71.0	29521	4.3307 110.000	0.7500 19.050	0.05 1.3	4.09 104.0	3.90 99.0	1.0000 25.400
			29586	2.5000 63.500	1.0000 25.400	0.06 1.5	-0.03 -0.8	2.87 73.0	2.80 71.0	▲ 29521B	4.3307 110.000	0.7500 19.050	0.05 1.3	4.13 105.0	—	1.0000 25.400
			29590	2.6250 66.675	1.0000 25.400	0.14 3.5	-0.03 -0.8	3.15 80.0	2.87 73.0	29522	4.2500 107.950	0.7500 19.050	0.03 0.8	4.06 103.0	3.86 98.0	1.0000 25.400
21400 95500	33500 149000	0.49 1.23	29600 Series													
			29675	2.7500 69.850	1.0000 25.400	0.06 1.5	0.04 1.0	3.15 80.0	3.03 77.0	29620	4.4375 112.712	0.7500 19.050	0.13 3.3	4.29 109.0	3.98 101.0	1.0000 25.400
			29680	2.7810 70.637	1.0000 25.400	0.05 1.3	0.04 1.0	3.15 80.0	3.07 78.0	▲ 29620B	4.4375 122.712	0.7500 19.050	0.13 3.3	4.33 110.0	—	1.0000 25.400
			29685	2.8750 73.025	1.0000 25.400	0.14 3.5	0.04 1.0	3.39 86.0	3.15 80.0	29621	4.4375 112.712	0.7500 19.050	0.03 0.8	4.29 109.0	4.21 107.0	1.0000 25.400
			29688	2.9062 73.817	1.0000 25.400	0.06 1.5	0.04 1.0	3.27 83.0	3.15 80.0	29630	4.7500 120.650	0.7500 19.050	0.13 3.3	4.45 113.0	4.09 104.0	1.0000 25.400
25300 113000	38000 169000	0.44 1.38	33000 Series													
			33225	2.2500 57.150	1.1875 30.162	0.14 3.5	-0.11 -2.8	2.91 74.0	2.68 68.0	33462	4.6250 117.475	0.9375 23.812	0.13 3.3	4.41 112.0	4.09 104.0	1.1875 30.162
			33262	2.6250 66.675	1.1875 30.162	0.14 3.5	-0.11 -2.8	3.19 81.0	2.95 75.0	▲ 33462B	4.6250 117.475	0.9375 23.812	0.13 3.3	4.49 114.0	—	1.1875 30.162
			33269	2.6875 68.262	1.1875 30.162	0.14 3.5	-0.11 -2.8	3.23 82.0	2.99 76.0	33472	4.7244 120.000	0.9230 23.444	0.03 0.8	4.45 113.0	4.21 107.0	1.1730 29.794
			33275	2.7500 69.850	1.1875 30.162	0.14 3.5	-0.11 -2.8	3.31 84.0	3.03 77.0	33475	4.7500 120.650	0.9230 23.444	0.03 0.8	4.53 115.0	4.53 115.0	1.1730 29.794
			33281	2.8125 71.438	1.1875 30.162	0.14 3.5	-0.11 -2.8	3.35 85.0	3.11 79.0							
			33287	2.8750 73.025	1.1875 30.162	0.14 3.5	-0.11 -2.8	3.43 87.0	3.15 80.0							
19100 85000	26500 118000	0.45 1.33	34000 Series													
			34274	2.7540 69.952	0.9060 23.012	0.08 2.0	0.06 1.5	3.19 81.0	3.07 78.0	34478	4.7812 121.442	0.6875 17.462	0.08 2.0	4.57 116.0	4.33 110.0	0.9688 24.608
			34275	2.7559 70.000	0.9060 23.012	0.08 2.0	0.06 1.5	3.19 81.0	3.11 79.0	▲ 34478B	4.7812 121.442	0.6875 17.462	0.06 1.5	4.65 118.0	—	0.9688 24.608
			34300	3.0000 76.200	0.9060 23.012	0.08 2.0	0.06 1.5	3.39 86.0	3.27 83.0	34492A	4.9233 125.052	0.6457 16.400	0.08 2.0	4.65 118.0	4.41 112.0	0.9343 23.731
			34301	3.0000 76.200	0.9060 23.012	0.14 3.5	0.06 1.5	3.50 89.0	3.27 83.0	34500	5.0000 127.000	0.7812 19.842	0.13 3.3	4.65 118.0	4.41 112.0	1.0625 26.988

* The maximum fillet on the shaft or in the housing that the bearing corner will clear.
† Positive value indicates the effective load center is outside the backface of the cone.
▲ For additional "B" cup dimensions, see pages 173 to 174.
■ For parts with a "J" prefix, use metric tolerances given on page 199 and fitting practice given on page 201.
★ Designate bearings with hollow rollers and pinned-type retainers.
◆ Bearing is equipped with seals (and in some instances side rings).

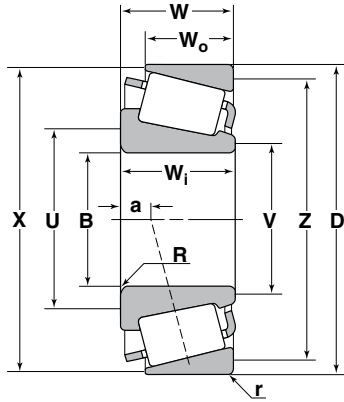

TS Type

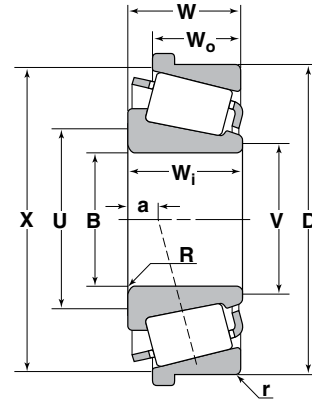

TSF Type

Basic Load Ratings		Axial Load Factor e Y_2	Cone Number	B	W_i	R	a	U	V	Cup Number	D	W_o	r	X	Z	W
Dynamic C_1	Static C_{or}			Bore Diameter	Cone Width	Maximum Shaft Fillet Radius*	Effective Load Center†	Minimum Shaft Shoulder Diameter	Minimum Shaft Shoulder Diameter		Outside Diameter	Cup Width	Maximum Housing Fillet Radius*	Maximum Housing Shoulder Diameter	Maximum Housing Shoulder Diameter	Bearing Width
lbs/N				Inch/mm						Inch/mm						
19100 85000	26500 118000	0.45 1.33	34000 Series (Cont'd)													
			34306	3.0625 77.788	0.9060 23.012	0.14 3.5	0.06 1.5	3.54 90.0	3.31 84.0							
			34307	3.0625 77.788	0.9060 23.012	0.25 6.4	0.06 1.5	3.78 96.0	3.31 84.0							
37500 167000	78500 350000	0.37 1.63	36600 Series													
			36690	5.7500 146.050	1.1250 28.575	0.06 1.5	0.19 4.8	6.10 155.0	6.02 153.0	36620	7.6250 193.675	0.9063 23.020	0.06 1.5	7.40 188.0	7.17 182.0	1.1250 28.575
			36691	5.7500 146.050	1.1250 28.575	0.19 4.8	0.19 4.8	6.38 162.0	6.02 153.0	▲ 36620B	7.6250 193.675	0.9063 23.020	0.06 1.5	7.48 190.0	—	1.1250 28.575
										36626	8.0000 203.200	0.9063 23.020	0.06 1.5	7.48 190.0	7.32 186.0	1.1250 28.575
40000 179000	91000 405000	0.44 1.36	36900 Series													
			36990	7.0000 177.800	1.1875 30.162	0.06 1.5	0.50 12.7	7.40 188.0	7.32 186.0	36920	8.9375 227.012	0.9063 23.020	0.06 1.5	8.70 221.0	8.43 214.0	1.1875 30.162
21800 97000	35000 157000	0.61 0.99	37000 Series													
			37425	4.2500 107.950	0.8440 21.438	0.14 3.5	0.54 13.7	4.80 122.0	4.53 115.0	37624	6.2500 158.750	0.6250 15.875	0.04 1.0	6.02 153.0	5.98 152.0	0.9063 23.020
			37431	4.3125 109.538	0.8440 21.438	0.14 3.5	0.54 13.7	4.84 123.0	4.57 116.0	37625	6.2500 158.750	0.6250 15.875	0.13 3.3	5.98 152.0	5.63 143.0	0.9063 23.020
			37431A	43.125 109.538	0.8440 21.438	0.20 5.0	0.54 13.7	5.24 133.0	4.61 117.0	▲ 37625B	6.2500 158.750	0.6250 15.875	0.13 3.3	6.02 153.0	—	0.9063 23.020

* The maximum fillet on the shaft or in the housing that the bearing corner will clear.
 † Positive value indicates the effective load center is outside the backface of the cone.
 ▲ For additional "B" cup dimensions, see pages 173 to 174.
 ■ For parts with a "J" prefix, use metric tolerances given on page 199 and fitting practice given on page 201.
 ★ Designate bearings with hollow rollers and pinned-type retainers.
 ◆ Bearing is equipped with seals (and in some instances side rings).

Basic Load Ratings		Axial Load Factor $e Y_2$	Cone Number	B	W _i	R	a	U	V	Cup Number	D	W _o	r	X	Z	W	
Dynamic C _r	Static C _{or}			Bore Diameter	Cone Width	Maximum Shaft Fillet Radius*	Effective Load Center†	Minimum Shaft Shoulder Diameter	Minimum Shaft Shoulder Diameter		Outside Diameter	Cup Width	Maximum Housing Fillet Radius*	Maximum Housing Shoulder Diameter	Maximum Housing Shoulder Diameter	Maximum Housing Shoulder Diameter	Bearing Width
lbs/N				Inch/mm							Inch/mm						
47500 211000	117000 520000	0.37 1.64	38800 Series														
			38800	10.3750 263.525	1.1250 28.575	0.06 1.5	0.80 20.3	10.83 275.0	10.83 275.0	38820	12.8125 325.438	1.0000 25.400	0.06 1.5	12.40 315.0	12.28 312.0	1.1250 28.575	
			38885	10.5000 266.700	1.1250 28.575	0.06 1.5	0.80 20.3	10.91 277.0	10.91 277.0								
17700 79000	22900 102000	0.39 1.55	39000 Series														
			39250	2.5000 63.500	0.8661 22.000	0.08 2.0	-0.06 -1.5	2.87 73.0	2.72 69.0	39412	4.1250 104.775	0.6250 15.875	0.08 2.0	3.94 100.0	3.78 96.0	0.8438 21.433	
										▲ 39412B	4.1250 104.775	0.6250 15.875	0.08 2.0	4.02 102.0	—	0.8438 21.433	
										39422	4.2188 107.158	0.8348 21.204	0.09 2.3	4.02 102.0	3.74 95.0	1.7317 43.985	
31000 138000	43500 194000	0.34 1.77	39500 Series														
			39573	2.0000 50.800	1.1875 30.162	0.03 0.8	-0.26 -6.6	2.44 62.0	2.40 61.0	39520	4.4375 112.712	0.9375 23.812	0.13 3.3	4.21 107.0	3.98 101.0	1.1875 30.162	
			39575	2.0000 50.800	1.1875 30.162	0.14 3.5	-0.26 -6.6	2.68 68.0	2.40 61.0	▲ 39520B	4.4375 112.712	0.9375 23.812	0.13 3.3	4.33 110.0	—	1.1875 30.162	
			39578	2.1250 53.975	1.1875 30.162	0.14 3.5	-0.26 -6.6	2.76 70.0	2.52 64.0	39521	4.4375 112.712	0.9375 23.812	0.03 0.8	4.21 107.0	4.06 103.0	1.1875 30.162	
			39580	2.2500 57.150	1.1875 30.162	0.14 3.5	-0.26 -6.6	2.83 72.0	2.60 66.0								
			39581	2.2500 57.150	1.1875 30.162	0.31 8.0	-0.26 -6.6	3.19 81.0	2.60 66.0								
			39585	2.5000 63.500	1.1875 30.162	0.14 3.5	-0.26 -6.6	3.03 77.0	2.80 71.0								
			39585A	2.5000 63.500	1.1875 30.162	0.03 0.8	-0.26 -6.6	2.83 72.0	2.80 71.0								
			39586	2.5586 64.988	1.2175 30.924	0.09 2.3	-0.26 -6.6	2.99 76.0	2.83 72.0								
			39589	2.6250 66.675	1.1875 30.162	0.06 1.5	-0.26 -6.6	2.95 75.0	2.91 74.0								
			39590	2.6250 66.675	1.1875 30.162	0.14 3.5	-0.26 -6.6	3.15 80.0	2.91 74.0								
			39590A	2.6240 66.650	1.1875 30.162	0.14 3.5	-0.26 -6.6	3.31 84.0	2.91 74.0								
			39591	2.6250 66.675	1.1875 30.162	0.22 5.6	-0.26 -6.6	3.31 84.0	2.91 74.0								
30500 136000	47500 210000	0.49 1.22	42000 Series														
			42346	3.4630 87.960	1.1406 28.971	0.12 3.0	0.12 3.0	4.06 103.0	3.86 98.0	42584	5.8437 148.430	0.8438 21.433	0.12 3.0	5.59 142.0	5.28 134.0	1.1250 28.575	
			42350	3.5000 88.900	1.1406 28.971	0.12 3.0	0.12 3.0	4.09 104.0	3.86 98.0	42585	5.8437 148.430	1.0000 25.400	0.13 3.3	5.63 143.0	5.24 133.0	1.1250 28.575	
			42362	3.6250 92.075	1.1406 28.971	0.14 3.5	0.12 3.0	4.21 107.0	3.98 101.0	42586	5.8437 148.430	1.2500 31.750	0.13 3.3	5.63 143.0	5.24 133.0	1.3750 34.925	
			42368	3.6875 93.662	1.1406 28.971	0.12 3.0	0.12 3.0	4.21 107.0	4.02 102.0	42587	5.8750 149.225	0.9688 24.608	0.13 3.3	5.63 143.0	5.28 134.0	1.2500 31.750	
			42375	3.7500 95.250	1.1406 28.971	0.12 3.0	0.12 3.0	4.25 108.0	4.06 103.0	▲ 42587B	5.8750 149.225	0.9688 24.608	0.13 3.3	5.98 152.0	—	1.2500 31.750	

* The maximum fillet on the shaft or in the housing that the bearing corner will clear.
 † Positive value indicates the effective load center is outside the backface of the cone.
 ▲ For additional "B" cup dimensions, see pages 173 to 174.
 ■ For parts with a "J" prefix, use metric tolerances given on page 199 and fitting practice given on page 201.
 ★ Designate bearings with hollow rollers and pinned-type retainers.
 ◆ Bearing is equipped with seals (and in some instances side rings).

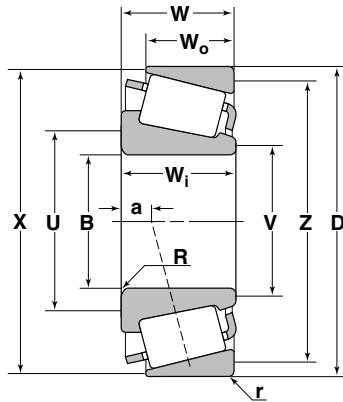

TS Type

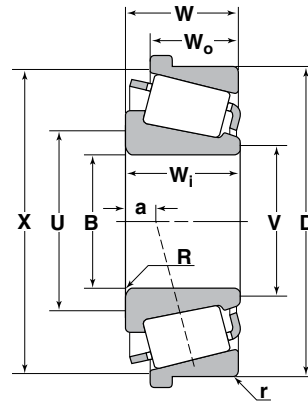

TSF Type

Basic Load Ratings		Axial Load Factor e Y_2	Cone Number	B	W_i	R	a	U	V	Cup Number	D	W_0	r	X	Z	W
Dynamic C_r	Static C_{or}			Bore Diameter	Cone Width	Maximum Shaft Fillet Radius †	Effective Load Center †	Minimum Shaft Shoulder Diameter	Minimum Shaft Shoulder Diameter		Outside Diameter	Cup Width	Maximum Housing Fillet Radius †	Maximum Housing Shoulder Diameter	Maximum Housing Shoulder Diameter	Bearing Width
lbs/N				Inch/mm						Inch/mm						
30500 136000	47500 210000	0.49 1.22	42000 Series (Cont'd)													
			42376	3.7500 95.250	1.1406 28.971	0.14 3.5	0.12 3.0	4.29 109.0	4.06 103.0							
			42381	3.8125 96.838	1.1406 28.971	0.14 3.5	0.12 3.0	4.33 110.0	4.09 104.0							
28900 129000	41500 185000	0.42 1.43	42600 Series													
			42687	3.0000 76.200	1.2205 31.000	0.14 3.5	-0.11 -2.8	3.54 90.0	3.31 84.0	42620	5.0000 127.000	0.8750 22.225	0.13 3.3	4.76 121.0	4.49 114.0	1.1875 30.162
			42688	3.0000 76.200	1.2205 31.000	0.25 6.4	-0.11 -2.8	3.78 96.0	3.31 84.0	▲ 42620B	5.0000 127.000	0.8750 22.225	0.13 3.3	4.88 124.0	—	1.1875 30.162
			42690	3.0625 77.788	1.2205 31.000	0.14 3.5	-0.11 -2.8	3.58 91.0	3.35 85.0							
28400 126000	36500 163000	0.33 1.80	45200 Series													
			45280	1.7500 44.450	1.2188 30.958	0.03 0.8	-0.32 -8.1	2.17 55.0	2.13 54.0	45220	4.1250 104.775	0.9375 23.812	0.13 3.3	3.90 99.0	3.66 93.0	1.1875 30.162
			45282	1.8750 47.625	1.2188 30.958	0.14 3.5	-0.32 -8.1	2.48 63.0	2.24 57.0	45221	4.1250 104.775	0.9375 23.812	0.03 0.8	3.90 99.0	3.74 95.0	1.1875 30.162
			45284	2.0000 50.800	1.2188 30.958	0.25 6.4	-0.32 -8.1	2.80 71.0	2.32 59.0							
			45285	2.0000 50.800	1.2188 30.958	0.09 2.3	-0.32 -8.1	2.48 63.0	2.32 59.0							
			45285A	2.0000 50.800	1.2188 30.958	0.03 0.8	-0.32 -8.1	2.36 60.0	2.32 59.0							
			45287	2.1250 53.975	1.2188 30.958	0.03 0.8	-0.32 -8.1	2.44 62.0	2.44 62.0							
			45289	2.2500 57.150	1.2188 30.958	0.03 0.8	-0.32 -8.1	2.56 65.0	2.56 65.0							

* The maximum fillet on the shaft or in the housing that the bearing corner will clear.
 † Positive value indicates the effective load center is outside the backface of the cone.
 ▲ For additional "B" cup dimensions, see pages 173 to 174.
 ■ For parts with a "J" prefix, use metric tolerances given on page 199 and fitting practice given on page 201.
 ★ Designate bearings with hollow rollers and pinned-type retainers.
 ◆ Bearing is equipped with seals (and in some instances side rings).

Basic Load Ratings		Axial Load Factor $e Y_2$	Cone Number	B	W_1	R	a	U	V	Cup Number	D	W_0	r	X	Z	W
Dynamic C_r	Static C_{or}			Bore Diameter	Cone Width	Maximum Shaft Fillet Radius †	Effective Load Center†	Minimum Shaft Shoulder Diameter	Minimum Shaft Shoulder Diameter		Outside Diameter	Cup Width	Maximum Housing Fillet Radius *	Maximum Housing Shoulder Diameter	Maximum Housing Shoulder Diameter	Maximum Housing Shoulder Diameter
lbs/N				Inch/mm						Inch/mm						
28400 126000	36500 163000	0.33 1.80	45200 Series (Cont'd)													
			45290	2.2500 57.150	1.2188 30.958	0.09 2.3	-0.32 -8.1	2.68 68.0	2.56 68.0							
			45291	2.2500 57.150	1.2188 30.958	0.25 6.4	-0.32 -8.1	2.99 76.0	2.56 65.0							
57000 253000	124000 555000	0.38 1.57	46700 Series													
			46780	6.2500 158.750	1.5625 39.688	0.14 3.5	0.10 2.5	6.93 176.0	6.65 169.0	46720	8.8750 225.425	1.3125 33.338	0.13 3.3	8.58 218.0	8.23 209.0	1.6250 41.275
			46790	6.5000 165.100	1.5625 39.688	0.14 3.5	0.10 2.5	7.13 181.0	6.85 174.0	▲ 46720B	8.8750 225.425	1.3125 33.338	0.13 3.3	8.62 219.0	—	1.6250 41.275
			46792	6.5625 166.688	1.5625 39.688	0.14 3.5	0.10 2.5	7.17 182.0	6.89 175.0							
33500 148000	48500 216000	0.36 1.67	47400 Series													
			47487	2.7500 69.850	1.2813 32.545	0.14 3.5	-0.25 -6.4	3.31 84.0	3.07 78.0	47420	4.7244 120.000	1.0313 26.195	0.13 3.3	4.49 114.0	4.21 107.0	1.2813 32.545
			47490	2.8125 71.438	1.2813 32.545	0.14 3.5	-0.25 -6.4	3.39 86.0	3.11 79.0	47420A	4.7244 120.000	1.0313 26.195	0.02 0.5	4.49 114.0	4.29 109.0	1.2813 32.545
35000 155000	53500 238000	0.40 1.48	47600 Series													
			47675	2.8125 71.438	1.3125 33.338	0.14 3.5	-0.17 -4.3	3.46 88.0	3.23 82.0	47620	5.2500 133.350	1.0313 26.195	0.13 3.3	5.04 128.0	4.69 119.0	1.3125 33.338
			47678	3.0000 76.200	1.3125 33.338	0.25 6.4	-0.17 -4.3	3.82 97.0	3.35 85.0	47620A	5.2500 133.350	1.0313 26.195	0.03 0.8	5.04 128.0	4.76 121.0	1.3125 33.338
			47679	3.0000 76.200	1.3125 33.338	0.14 3.5	-0.17 -4.3	3.58 91.0	3.35 85.0	▲ 47620B	5.2500 133.350	1.0313 26.195	0.13 3.3	5.12 130.0	—	1.3125 33.338
			47680	3.0000 76.200	1.3125 33.338	0.03 0.8	-0.17 -4.3	3.39 86.0	3.35 85.0	47622W	5.3750 136.525	2.1875 55.562	0.13 3.3	5.16 131.0	4.76 121.0	2.1875 55.562
			47681	3.1875 80.962	1.3125 33.338	0.14 3.5	-0.17 -4.3	3.74 95.0	3.50 89.0	47623A	5.3750 136.525	1.7500 44.450	—	5.16 131.0	—	1.7500 44.450
			47685	3.2500 82.550	1.3125 33.338	0.03 0.8	-0.17 -4.3	3.58 91.0	3.54 90.0							
			47686	3.2500 82.550	1.3125 33.338	0.14 3.5	-0.17 -4.3	3.82 97.0	3.54 90.0							
			47687	3.2500 82.550	1.3125 33.338	0.27 6.8	-0.17 -4.3	4.06 103.0	3.54 90.0							
37000 165000	60500 269000	0.45 1.34	47800 Series													
			47890	3.6250 92.075	1.3750 34.925	0.14 3.5	-0.04 -1.0	4.21 107.0	3.98 101.0	47820	5.7500 146.050	1.0313 26.195	0.13 3.3	5.51 140.0	5.16 131.0	1.3125 33.338
			47896	3.7500 95.250	1.3750 34.925	0.14 3.5	-0.04 -1.0	4.33 110.0	4.06 103.0	▲ 47825B	5.6250 142.875	1.0313 26.195	0.06 1.5	5.59 142.0	—	1.3125 33.338

* The maximum fillet on the shaft or in the housing that the bearing corner will clear.

† Positive value indicates the effective load center is outside the backface of the cone.

▲ For additional "B" cup dimensions, see pages 173 to 174.

■ For parts with a "J" prefix, use metric tolerances given on page 199 and fitting practice given on page 201.

★ Designate bearings with hollow rollers and pinned-type retainers.

◆ Bearing is equipped with seals (and in some instances side rings).

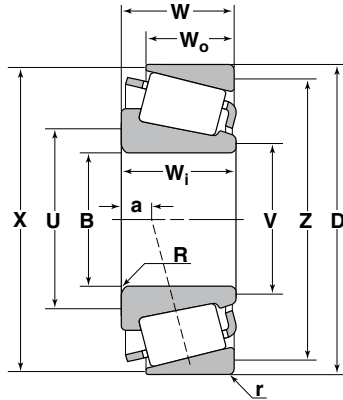

TS Type

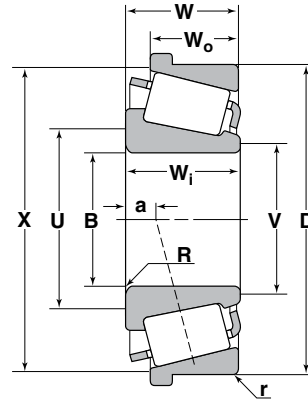

TSF Type

Basic Load Ratings		Axial Load Factor e Y_2	Cone Number	B	W_i	R	a	U	V	Cup Number	D	W_o	r	X	Z	W
Dynamic C_r	Static C_{or}			Bore Diameter	Cone Width	Maximum Shaft Fillet Radius *	Effective Load Center†	Minimum Shaft Shoulder Diameter	Minimum Shaft Shoulder Diameter		Outside Diameter	Cup Width	Maximum Housing Fillet Radius *	Maximum Housing Shoulder Diameter	Maximum Housing Shoulder Diameter	Bearing Width
lbs/N				Inch/mm									Inch/mm			
44000 196000	79500 355000	0.65 0.92	48000 Series													
			48506	5.0625 128.588	1.2500 31.750	0.14 3.5	0.65 16.5	5.67 144.0	5.43 138.0	48750	7.5000 190.500	1.0000 25.400	0.13 3.3	7.20 183.0	6.69 170.0	1.3750 34.925
36000 160000	60500 270000	0.51 1.19	48100 Series													
			48190	4.2500 107.950	1.3750 34.925	0.14 3.5	0.15 3.8	4.80 122.0	4.57 116.0	48120	6.3750 161.925	1.0625 26.988	0.13 3.3	6.14 156.0	5.75 146.0	1.3750 34.922
50500 224000	97000 430000	0.31 1.97	48200 Series													
			48286	4.8750 123.825	1.5000 38.100	0.14 3.5	-0.22 -5.6	5.47 139.0	5.24 133.0	48220	7.1875 182.562	1.3125 33.338	0.13 3.3	6.93 176.0	6.61 168.0	1.5625 39.688
			48290	5.0000 127.000	1.5000 38.100	0.14 3.5	-0.22 -5.6	5.55 141.0	5.31 135.0	▲ 48220B	7.1875 182.562	1.3125 33.338	0.13 3.3	6.97 177.0	—	1.5625 39.688
53000 236000	106000 475000	0.32 1.87	48300 Series													
			48384A	5.2460 133.248	1.5625 39.688	0.14 3.5	-0.16 -4.1	5.91 150.0	5.99 142.0	48320	7.5000 190.500	1.3125 33.338	0.13 3.3	7.24 184.0	6.97 177.0	1.5625 39.688
			48385	5.2500 133.350	1.5625 39.688	0.14 3.5	-0.16 -4.1	5.83 148.0	5.59 142.0	▲ 48320B	7.5000 190.500	1.3125 33.338	0.13 3.3	7.32 186.0	—	1.5625 39.688
			48385A	5.2500 133.350	1.5625 39.588	0.14 3.5	-0.16 -4.1	5.83 148.0	5.59 142.0							
			48393	5.3750 136.525	1.5625 39.688	0.14 3.5	-0.16 -4.1	5.94 151.0	5.67 144.0							
			48393A	5.3750 136.525	1.5625 39.688	0.22 5.6	-0.16 -4.1	6.02 153.0	5.67 144.0							
53500 238000	109000 485000	0.34 1.78	48600 Series													
			48684	5.6250 142.875	1.5625 39.688	0.31 8.0	-0.12 -3.0	6.54 166.0	5.94 151.0	48620	7.8750 200.025	1.3437 34.130	0.13 3.3	7.60 193.0	7.28 185.0	1.6250 41.275
			48685	5.6250 142.875	1.5625 39.688	0.14 3.5	-0.12 -3.0	6.22 158.0	5.94 151.0	▲ 48620B	7.8750 200.025	1.3437 34.130	0.13 3.3	7.64 194.0	—	1.6250 41.275

* The maximum fillet on the shaft or in the housing that the bearing corner will clear.

† Positive value indicates the effective load center is outside the backface of the cone.

▲ For additional "B" cup dimensions, see pages 173 to 174.

■ For parts with a "J" prefix, use metric tolerances given on page 199 and fitting practice given on page 201.

★ Designate bearings with hollow rollers and pinned-type retainers.

◆ Bearing is equipped with seals (and in some instances side rings).

Basic Load Ratings		Axial Load Factor $e Y_2$	Cone Number	B	W_i	R	a	U	V	Cup Number	D	W_o	r	X	Z	W
Dynamic C_r	Static C_{or}			Bore Diameter	Cone Width	Maximum Shaft Fillet Radius *	Effective Load Center†	Minimum Shaft Shoulder Diameter	Minimum Shaft Shoulder Diameter		Outside Diameter	Cup Width	Maximum Housing Fillet Radius *	Maximum Housing Shoulder Diameter	Maximum Housing Shoulder Diameter	Bearing Width
lbs/N				Inch/mm								Inch/mm				
24700 110000	30500 135000	0.40 1.50	49500 Series													
			49576	1.7500 44.450	1.2500 31.750	0.03 0.8	-0.28 -7.1	2.17 55.0	2.13 54.0	49520	4.0000 101.600	1.0000 25.400	0.13 3.3	3.78 96.0	3.46 88.0	1.2500 31.750
			49577	1.7500 44.450	1.2500 31.750	0.14 3.5	-0.28 -7.1	2.40 61.0	2.05 52.0	▲ 49520B	4.0000 101.600	1.0000 25.400	0.13 3.3	3.86 98.0	—	1.2500 31.750
			49580	1.8750 47.625	1.2500 31.750	0.14 3.5	-0.28 -7.1	2.36 60.0	2.17 55.0	49521	4.0000 101.600	1.1250 28.575	0.13 3.3	3.78 96.0	3.46 88.0	1.3750 34.925
			49585	2.0000 50.800	1.2500 31.750	0.14 3.5	-0.28 -7.1	2.60 66.0	2.32 59.0	49522	4.0000 101.600	1.0000 25.400	0.03 0.8	3.78 96.0	3.46 88.0	1.2500 31.750
41500 186000	67000 298000	0.47 1.26	52000 Series													
			52375	3.7500 95.250	1.4219 36.116	0.14 3.5	-0.01 -0.3	4.41 112.0	4.13 105.0	52618	6.1875 157.162	1.0313 26.195	0.13 3.3	5.98 152.0	5.59 142.0	1.4375 36.512
			52387	3.8750 98.425	1.4219 36.116	0.14 3.5	-0.01 -0.3	4.49 114.0	4.25 108.0	52637	6.3750 161.925	1.0313 26.195	0.13 3.3	6.06 154.0	5.67 144.0	1.4375 36.512
			52393	3.9375 100.012	1.4219 36.116	0.14 3.5	-0.01 -0.3	4.57 116.0	4.29 109.0	▲ 52637B	6.3750 161.925	1.0313 26.195	0.13 3.3	6.10 155.0	—	1.4375 36.512
			52400	4.0000 101.600	1.4219 36.116	0.14 3.5	-0.01 -0.3	4.61 117.0	4.37 111.0	52638	6.3750 161.925	1.1563 29.370	0.13 3.3	6.06 154.0	5.63 143.0	1.5625 39.688
			52400A	4.0000 101.600	1.4219 36.116	0.14 3.5	-0.01 -0.3	4.61 117.0	4.37 111.0	52639	6.3750 161.925	1.5625 39.688	0.13 3.3	6.18 157.0	5.83 148.0	1.6250 41.275
			52401	4.0000 101.600	1.4219 36.116	0.31 8.0	-0.01 -0.3	5.35 136.0	4.29 109.0							
23400 104000	31000 137000	0.88 0.68	55000C Series													
			55175C	1.7500 44.450	1.0594 26.909	0.14 3.5	0.30 7.6	2.76 70.0	2.52 64.0	55437	4.3750 111.125	0.8125 20.638	0.13 3.3	4.13 105.0	3.62 92.0	1.1875 30.162
			55176C	1.7500 44.450	1.0594 26.909	0.03 0.8	0.30 7.6	2.56 65.0	2.54 64.5	▲ 55437B	4.3750 111.125	0.8125 20.638	0.13 3.3	4.21 107.0	—	1.1875 30.162
			55187C	1.8750 47.625	1.0594 26.909	0.14 3.5	0.30 7.6	2.72 69.0	2.44 62.0	55443	4.4375 112.712	0.8125 20.638	0.13 3.3	4.17 106.0	3.62 92.0	1.1875 30.162
			55196C	1.9675 49.974	1.0594 26.909	0.14 3.5	0.30 7.6	2.80 71.0	2.54 64.5							
			55197C	1.6968 43.099	1.0594 26.909	0.08 2.0	0.30 7.6	2.80 71.0	2.54 64.5							
			55200C	2.0000 50.800	1.0594 26.909	0.14 3.5	0.30 7.6	2.80 71.0	2.54 64.5							
			55206C	2.0625 52.388	1.0594 26.909	0.14 3.5	0.30 7.6	2.83 72.0	2.54 64.5							
			55212C	2.1250 53.975	1.0594 26.909	0.14 3.5	0.30 7.6	2.80 71.0	2.44 62.0							

* The maximum fillet on the shaft or in the housing that the bearing corner will clear.

† Positive value indicates the effective load center is outside the backface of the cone.

▲ For additional "B" cup dimensions, see pages 173 to 174.

■ For parts with a "J" prefix, use metric tolerances given on page 199 and fitting practice given on page 201.

★ Designate bearings with hollow rollers and pinned-type retainers.

◆ Bearing is equipped with seals (and in some instances side rings).

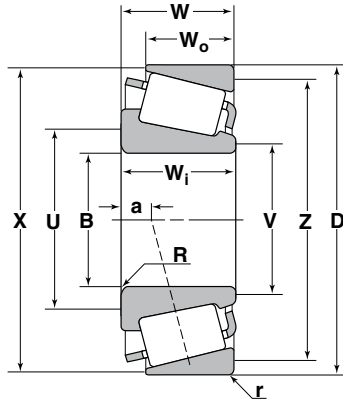

TS Type

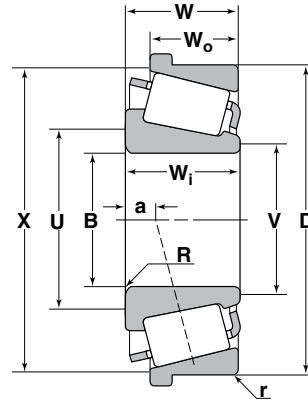

TSF Type

Basic Load Ratings		Axial Load Factor e Y_2	Cone Number	B	W_i	R	a	U	V	Cup Number	D	W_o	r	X	Z	W
Dynamic C_r	Static C_{or}			Bore Diameter	Cone Width	Maximum Shaft Fillet Radius*	Effective Load Center†	Minimum Shaft Shoulder Diameter	Minimum Shaft Shoulder Diameter		Outside Diameter	Cup Width	Maximum Housing Fillet Radius*	Maximum Housing Shoulder Diameter	Maximum Housing Shoulder Diameter	Bearing Width
lbs/N				Inch/mm						Inch/mm						
42500 189000	69500 310000	0.50 1.21	56000 Series													
			56418	4.1875 106.362	1.4375 36.512	0.14 3.5	0.08 2.0	4.80 122.0	4.57 116.0	56650	6.5000 165.100	1.0625 26.988	0.13 3.3	6.26 159.0	5.87 149.0	1.4375 36.512
			56425	4.2500 107.950	1.4375 36.512	0.14 3.5	0.08 2.0	4.48 123.0	4.61 117.0	▲ 56650B	6.5000 165.100	1.0625 26.988	0.13 3.3	6.38 162.0	—	1.4375 36.512
										56662	6.6250 168.275	1.0625 26.988	0.13 3.3	6.34 161.0	5.94 151.0	1.4375 36.512
31500 140000	39000 174000	0.40 1.49	59000 Series													
			59162	1.6250 41.275	1.4375 36.512	0.06 1.5	-0.38 -9.7	1.97 50.0	1.97 50.0	59412	4.1250 104.775	1.1250 28.575	0.13 3.3	3.90 99.0	3.62 92.0	1.4375 36.512
			59175	1.7500 44.450	1.4375 36.512	0.14 3.5	-0.38 -9.7	2.48 63.0	2.20 56.0	▲ 59414B	4.1250 104.775	1.1250 28.575	0.13 3.3	3.90 99.0	—	1.4375 36.512
			59187	1.8750 47.625	1.4375 36.512	0.14 3.5	-0.38 -9.7	2.56 65.0	2.32 59.0	59425	4.2500 107.950	1.1250 28.575	0.13 3.3	3.98 101.0	3.66 93.0	1.4375 36.512
			59200	2.0000 50.800	1.4375 36.512	0.14 3.5	-0.38 -9.7	2.68 68.0	2.40 61.0	59429	4.2900 108.966	1.0625 26.988	0.13 3.3	4.09 104.0	3.66 93.0	1.3750 34.925
			59201	2.0000 50.800	1.4375 36.512	0.03 0.8	-0.38 -9.7	2.44 62.0	2.40 61.0	▲ 59429B	4.2900 108.966	1.0625 26.988	0.13 3.3	4.09 104.0	—	1.3750 34.925
52000 231000	83500 370000	0.52 1.16	64000 Series													
			64432	4.3297 109.974	1.6250 41.275	0.14 3.5	0.05 1.3	5.04 128.0	4.76 121.0	64700	7.0000 177.800	1.1875 30.162	0.13 3.3	6.77 172.0	6.30 160.0	1.6250 41.275
			64433	4.3304 109.992	1.6250 41.275	0.14 3.5	0.05 1.3	5.04 128.0	4.76 121.0	▲ 64700B	7.0000 177.800	1.1875 30.162	0.13 3.3	6.85 174.0	—	1.6250 41.275
			64450	4.5000 114.300	1.6250 41.275	0.14 3.5	0.05 1.3	5.16 131.0	4.92 125.0	64708	7.0856 179.974	1.1875 30.162	0.13 3.3	6.81 173.0	6.34 161.0	1.6250 41.275
			64452A	4.5266 114.976	1.6250 41.275	0.35 9.0	0.05 1.3	5.63 143.0	4.96 126.0							

* The maximum fillet on the shaft or in the housing that the bearing corner will clear.
 † Positive value indicates the effective load center is outside the backface of the cone.
 ▲ For additional "B" cup dimensions, see pages 173 to 174.
 ■ For parts with a "J" prefix, use metric tolerances given on page 199 and fitting practice given on page 201.
 ★ Designate bearings with hollow rollers and pinned-type retainers.
 ◆ Bearing is equipped with seals (and in some instances side rings).

Basic Load Ratings		Axial Load Factor $e Y_2$	Cone Number	B	W_i	R	a	U	V	Cup Number	D	W_o	r	X	Z	W	
Dynamic C_r	Static C_{or}			Bore Diameter	Cone Width	Maximum Shaft Fillet Radius *	Effective Load Center†	Minimum Shaft Shoulder Diameter	Minimum Shaft Shoulder Diameter		Outside Diameter	Cup Width	Maximum Housing Fillet Radius *	Maximum Housing Shoulder Diameter	Maximum Housing Shoulder Diameter	Maximum Housing Shoulder Diameter	Bearing Width
lbs/N				Inch/mm								Inch/mm					
45000 200000	58000 258000	0.49 1.23	65000 Series														
			65200	2.0000 50.800	1.7500 44.450	0.14 3.5	-0.37 -9.4	2.95 75.0	2.72 69.0	65500	5.0000 127.000	1.3750 34.925	0.13 3.3	4.69 119.0	4.21 107.0	1.7500 44.450	
			65212	2.1250 53.975	1.7500 44.450	0.14 3.5	-0.37 -9.4	3.03 77.0	2.79 71.0	▲ 65500B	5.0000 127.000	1.3750 34.925	0.13 3.3	4.72 120.0	— —	1.7500 44.450	
			65225	2.2500 57.150	1.7500 44.450	0.14 3.5	-0.37 -9.4	3.15 80.0	2.79 71.0								
			65231	2.3125 58.738	1.7500 44.450	0.14 3.5	-0.37 -9.4	2.99 76.0	2.68 68.0								
			65237	2.3750 60.325	1.7500 44.450	0.14 3.5	-0.37 -9.4	3.23 82.0	2.79 71.0								
			65237A	2.3750 60.325	1.7500 44.450	0.06 1.5	-0.37 -9.4	3.07 78.0	2.79 71.0								
41000 183000	49500 221000	0.43 1.40	65300 Series														
			65384	1.7500 44.450	1.7500 44.450	0.08 2.0	-0.49 -12.4	2.17 55.0	2.09 53.0	65320	4.5000 114.300	1.3750 34.925	0.13 3.3	4.21 107.0	3.82 97.0	1.7500 44.450	
			65385	1.7500 44.450	1.7500 44.450	0.14 3.5	-0.49 -12.4	2.24 57.0	2.05 52.0	▲ 65320B	4.5000 114.300	1.3750 34.925	0.13 3.3	4.21 107.0	— —	1.7500 44.450	
			65390	1.9375 49.212	1.7500 44.450	0.14 3.5	-0.49 -12.4	2.76 70.0	2.36 60.0								
			65395	2.0000 50.800	1.7500 44.450	0.14 3.5	-0.49 -12.4	2.83 72.0	2.36 60.0								
28300 126000	33000 147000	0.63 0.96	66000 Series														
			66187	1.8750 47.625	1.2500 31.750	0.14 3.5	-0.01 -0.3	2.56 65.0	2.20 56.0	66462	4.6250 117.475	0.9375 23.812	0.13 3.3	4.37 111.0	3.94 100.0	1.3125 33.338	
			66200	2.0000 50.800	1.2500 31.750	0.14 3.5	-0.01 -0.3	2.80 71.0	2.56 65.0	▲ 66462B	4.6250 117.475	0.9375 23.812	0.13 3.3	4.45 113.0	— —	1.3125 33.338	
			66212	2.3622 53.975	1.2500 31.750	0.14 3.5	-0.01 -0.3	2.87 73.0	2.64 67.0								
			66225	2.2500 57.150	1.2500 31.750	0.14 3.5	-0.01 -0.3	2.99 76.0	2.71 69.0								
29300 130000	33000 147000	0.67 0.90	66500 Series														
			66584	2.1250 53.975	1.2500 31.750	0.14 3.5	0.08 2.0	2.95 75.0	2.68 68.0	66520	4.8125 122.238	0.9375 23.812	0.13 3.3	4.57 116.0	4.13 105.0	1.3125 33.338	
			66585	2.3622 60.000	1.2500 31.750	0.14 3.5	0.08 2.0	3.11 79.0	2.87 73.0								
			66586	2.3613 59.977	1.2500 31.750	0.06 1.5	0.08 2.0	2.72 69.0	2.72 69.0								
			66589	2.3611 59.972	1.2500 31.750	0.03 0.8	0.08 2.0	2.91 74.0	2.87 73.0								
68500 305000	122000 540000	0.34 1.74	67300 Series														
			67388	5.0000 127.000	1.8125 46.038	0.14 3.5	-0.25 -6.4	5.67 144.0	5.43 138.0	67320	8.0000 203.200	1.5000 38.100	0.13 3.3	7.52 191.0	7.20 183.0	1.8125 46.038	
			67389	5.1250 130.175	1.8125 46.038	0.14 3.5	-0.25 -6.4	5.75 146.0	5.55 141.0	▲ 67320B	8.0000 203.200	1.5000 38.100	0.13 3.3	7.52 191.0	— —	1.8125 46.038	

* The maximum fillet on the shaft or in the housing that the bearing corner will clear.
 † Positive value indicates the effective load center is outside the backface of the cone.
 ▲ For additional "B" cup dimensions, see pages 173 to 174.
 ■ For parts with a "J" prefix, use metric tolerances given on page 199 and fitting practice given on page 201.
 ★ Designate bearings with hollow rollers and pinned-type retainers.
 ◆ Bearing is equipped with seals (and in some instances side rings).

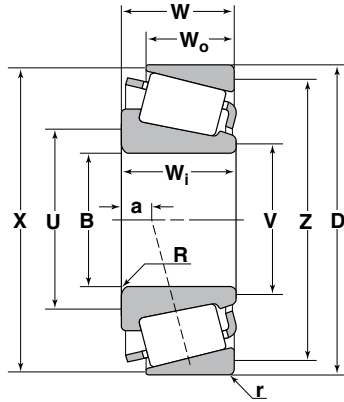

TS Type

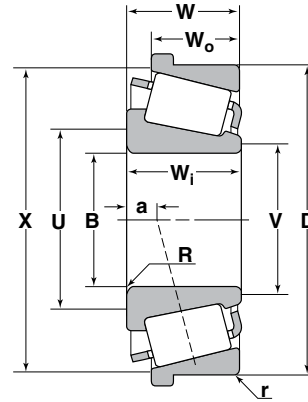

TSF Type

Basic Load Ratings		Axial Load Factor e Y_2	Cone Number	B	W_i	R	a	U	V	Cup Number	D	W_o	r	X	Z	W
Dynamic C_r	Static C_{or}			Bore Diameter	Cone Width	Maximum Shaft Fillet Radius*	Effective Load Center†	Minimum Shaft Shoulder Diameter	Minimum Shaft Shoulder Diameter		Outside Diameter	Cup Width	Maximum Housing Fillet Radius*	Maximum Housing Shoulder Diameter	Maximum Housing Shoulder Diameter	Bearing Width
lbs/N				Inch/mm						Inch/mm						
68500 305000	122000 540000	0.34 1.74	67300 Series (Cont'd)													
			67390	5.2500 133.350	1.8125 46.038	0.14 3.5	-0.25 -6.4	5.87 149.0	5.63 143.0	67322	7.7500 196.850	1.5000 38.100	0.13 3.3	7.44 189.0	7.09 180.0	1.8125 46.038
			67391	5.2500 133.350	1.8125 46.038	0.31 8.0	-0.25 -6.4	6.18 157.0	5.63 143.0	▲ 67322B	7.7500 196.850	1.5000 38.100	0.13 3.3	7.52 191.0	—	1.8125 46.038
										67324	8.0000 203.200	1.8125 46.038	0.13 3.3	7.83 199.0	7.36 187.0	1.8125 46.038
75500 335000	152000 680000	0.44 1.36	67700 Series													
			67780	6.5000 165.100	1.8750 47.625	0.14 3.5	0.19 4.8	7.28 185.0	7.05 179.0	67720	9.7500 247.650	1.5000 38.100	0.13 3.3	9.45 240.0	9.02 229.0	1.8750 47.625
			67782	6.6250 168.275	1.8750 47.625	0.14 3.5	0.19 4.8	7.36 187.0	7.13 181.0	▲ 67720B	9.7500 247.650	1.5000 38.100	0.13 3.3	9.49 241.0	—	1.8750 47.625
			67786	6.8750 174.625	1.8750 47.625	0.31 8.0	0.19 4.8	7.87 200.0	7.28 185.0							
			67787	6.8750 174.625	1.8750 47.625	0.14 3.5	0.19 4.8	7.56 192.0	7.28 185.0							
			67790	7.0000 177.800	1.8750 47.625	0.14 3.5	0.19 4.8	7.64 194.0	7.40 188.0							
			67791	7.0000 177.800	1.8750 47.625	0.41 10.5	0.19 4.8	8.19 208.0	7.40 188.0							
78500 350000	165000 735000	0.48 1.26	67800 Series													
			67883	7.2500 184.150	1.8438 46.833	0.14 3.5	0.40 10.2	8.03 204.0	7.80 198.0	67820	10.5000 266.700	1.5000 38.100	0.13 3.3	10.20 259.0	9.69 246.0	1.8750 47.625
			67884	7.3750 187.325	1.8438 46.833	0.14 3.5	0.40 10.2	8.11 206.0	7.91 201.0	▲ 67820B	10.5000 266.700	1.5000 38.100	0.13 3.3	10.20 259.0	—	1.8750 47.625
			67885	7.5000 190.500	1.8438 46.833	0.14 3.5	0.40 10.2	8.23 209.0	7.99 203.0							
			67887	7.5625 192.088	1.8438 46.833	0.41 10.5	0.40 10.2	8.78 223.0	8.03 204.0							

* The maximum fillet on the shaft or in the housing that the bearing corner will clear.

† Positive value indicates the effective load center is outside the backface of the cone.

▲ For additional "B" cup dimensions, see pages 173 to 174.

■ For parts with a "J" prefix, use metric tolerances given on page 199 and fitting practice given on page 201.

★ Designate bearings with hollow rollers and pinned-type retainers.

◆ Bearing is equipped with seals (and in some instances side rings).

Basic Load Ratings		Axial Load Factor e_{Y_2}	Cone Number	B	W _i	R	a	U	V	Cup Number	D	W _O	r	X	Z	W
Dynamic C _r	Static C _{or}			Bore Diameter	Cone Width	Maximum Shaft Fillet Radius †	Effective Load Center†	Minimum Shaft Shoulder Diameter	Minimum Shaft Shoulder Diameter		Outside Diameter	Cup Width	Maximum Housing Fillet Radius †	Maximum Housing Shoulder Diameter	Maximum Housing Shoulder Diameter	Bearing Width
lbs/N			Inch/mm							Inch/mm						
80000 355000	173000 770000	0.51 1.18	67900 Series													
			67983	8.0000 203.200	1.8125 46.038	0.14 3.5	0.63 16.0	8.74 222.0	8.50 216.0	67920	11.1250 282.575	1.4375 36.512	0.13 3.3	10.83 275.0	10.24 260.0	1.8125 46.038
			67985	8.1250 206.375	1.8125 46.038	0.14 3.5	0.63 16.0	8.82 224.0	8.62 219.0	▲ 67920B	11.1250 282.575	1.4375 36.512	0.13 3.3	10.83 275.0	—	1.8125 46.038
			67989	8.2500 209.550	1.8125 46.038	0.14 3.5	0.63 16.0	8.94 227.0	8.70 221.0							
37000 164000	53000 237000	0.50 1.21	68000 Series													
			68450	4.5000 114.300	1.2500 31.750	0.14 3.5	0.21 5.3	5.12 130.0	4.84 123.0	68709	7.0856 179.974	1.0000 25.400	0.03 0.8	6.77 172.0	6.50 165.0	1.3750 34.925
			68462	4.6250 117.475	1.2500 31.750	0.14 3.5	0.21 5.3	5.20 132.0	4.92 125.0	68712	7.1250 180.975	1.0000 25.400	0.13 3.3	6.77 172.0	6.42 163.0	1.3750 34.925
			68463	4.6250 117.475	1.2500 31.750	0.31 8.0	0.21 5.3	5.51 140.0	4.92 125.0	▲ 68712B	7.1250 180.975	1.0000 25.400	0.13 3.3	6.77 172.0	—	1.3750 34.925
67500 300000	106000 470000	0.42 1.44	71000 Series													
			71412	4.1250 104.775	1.9375 74.212	0.14 3.5	-0.26 -6.6	4.88 124.0	4.65 118.0	71750	7.5000 190.500	1.3750 34.925	0.13 3.3	7.13 181.0	6.73 171.0	1.8750 47.625
			71425	4.2500 107.950	1.9375 74.212	0.14 3.5	-0.26 -6.6	4.96 126.0	4.72 124.0	▲ 71750B	7.5000 190.500	1.3750 34.925	0.13 3.3	7.13 181.0	—	1.8750 47.625
			71432	4.3288 109.952	1.9375 74.212	0.14 3.5	-0.26 -6.6	5.00 127.0	4.69 119.0							
			71437	4.3750 111.125	1.9375 74.212	0.14 3.5	-0.26 -6.6	5.08 129.0	4.84 123.0							
			71450	4.5000 114.300	1.9375 74.212	0.14 3.5	-0.26 -6.6	5.20 132.0	4.92 125.0							
			71451	4.5000 114.300	1.9375 74.212	0.14 3.5	-0.26 -6.6	5.20 132.0	4.92 125.0							
			71453	4.5310 115.087	1.9375 74.212	0.14 3.5	-0.26 -6.6	5.24 133.0	4.96 126.0							
			71455	4.5310 115.087	1.9375 74.212	0.31 8.0	-0.26 -6.6	5.55 141.0	4.96 126.0							
35000 155000	42500 188000	0.74 0.81	72000C Series													
			72187C	1.8750 47.625	1.2910 32.791	0.14 3.5	0.08 2.0	2.72 69.0	2.63 67.0	72487	4.8750 123.825	1.0000 25.400	0.13 3.3	4.57 116.0	4.02 102.0	1.4375 36.512
			72188C	1.8750 47.625	1.2910 32.791	0.03 0.8	0.08 2.0	2.72 69.0	2.63 67.0	72500	5.0000 127.000	1.0000 25.400	0.13 3.3	4.69 119.0	4.37 111.0	1.4375 36.512
			72200C	2.0000 50.800	1.2910 32.791	0.14 3.5	0.08 2.0	3.03 77.0	2.64 67.0							
			72201C	2.0000 50.800	1.2910 32.791	0.03 0.8	0.08 2.0	3.03 77.0	2.64 67.0							
			72212C	2.1250 53.975	1.2910 32.791	0.14 3.5	0.08 2.0	3.11 79.0	2.64 67.0							
			72218C	2.1875 55.562	1.2910 32.791	0.14 3.5	0.08 2.0	3.15 80.0	2.64 67.0							
			72225C	2.2500 57.150	1.2910 32.791	0.14 3.5	0.08 2.0	3.19 81.0	2.64 67.0							

* The maximum fillet on the shaft or in the housing that the bearing corner will clear.
† Positive value indicates the effective load center is outside the backface of the cone.
▲ For additional "B" cup dimensions, see pages 173 to 174.
■ For parts with a "J" prefix, use metric tolerances given on page 199 and fitting practice given on page 201.
★ Designate bearings with hollow rollers and pinned-type retainers.
◆ Bearing is equipped with seals (and in some instances side rings).

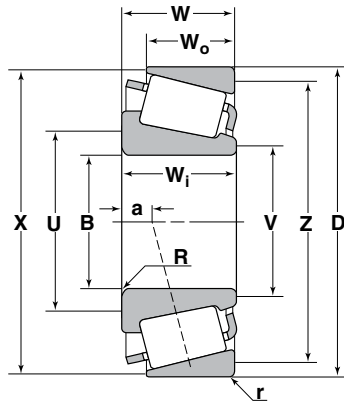

TS Type

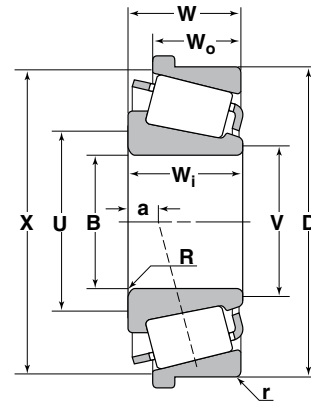

TSF Type

Basic Load Ratings		Axial Load Factor e Y_2	Cone Number	B	W_i	R	a	U	V	Cup Number	D	W_o	r	X	Z	W
Dynamic C_r	Static C_{or}			Bore Diameter	Cone Width	Maximum Shaft Fillet Radius *	Effective Load Center†	Minimum Shaft Shoulder Diameter	Minimum Shaft Shoulder Diameter		Outside Diameter	Cup Width	Maximum Housing Fillet Radius *	Maximum Housing Shoulder Diameter	Maximum Housing Shoulder Diameter	Bearing Width
lbs/N				Inch/mm						Inch/mm						
71500 315000	121000 535000	0.49 1.23	74000 Series													
			74472	4.7230 119.964	1.8750 47.625	0.14 3.5	0.09 2.3	5.39 137.0	5.08 129.0	74845	8.4636 214.975	1.3750 34.925	0.13 3.3	8.19 208.0	7.72 196.0	1.8750 47.625
			74500	5.0000 127.000	1.8750 47.625	0.14 3.5	0.09 2.3	5.83 148.0	5.55 141.0	74850	8.5000 215.900	1.3750 34.925	0.13 3.3	8.19 208.0	7.72 196.0	1.8750 47.625
			74525	5.2500 133.350	1.8750 47.625	0.14 3.5	0.09 2.3	5.98 152.0	5.75 146.0	▲ 74850B	8.5000 215.900	1.3750 34.925	0.13 3.3	8.23 209.0	—	1.8750 47.625
			74537	5.3750 136.525	1.8750 47.625	0.14 3.5	0.09 2.3	6.10 155.0	5.83 148.0							
			74550	5.5000 139.700	1.8750 47.625	0.14 3.5	0.09 2.3	6.22 158.0	5.94 151.0							
			74550A	5.5000 139.700	1.8750 47.625	0.25 6.4	0.09 2.3	6.42 163.0	5.94 151.0							
62000 276000	91000 405000	0.37 1.63	77000 Series													
			77350	3.5000 88.900	1.9000 48.260	0.20 5.0	-0.38 -9.7	4.33 110.0	3.98 101.0	77675	6.7500 171.450	1.5000 38.100	0.13 3.3	6.34 161.0	6.02 153.0	1.8750 47.625
			77362	3.6250 92.075	1.9000 48.260	0.14 3.5	-0.38 -9.7	4.29 109.0	4.06 103.0	▲ 77675B	6.7500 171.450	1.5000 38.100	0.13 3.3	6.34 161.0	—	1.8750 47.625
			77364	3.6250 92.075	1.9000 48.260	0.25 6.4	-0.38 -9.7	4.72 120.0	3.98 101.0							
			77375	3.7500 95.250	1.9000 48.260	0.14 3.5	-0.38 -9.7	4.45 113.0	4.17 106.0							

* The maximum fillet on the shaft or in the housing that the bearing corner will clear.
 † Positive value indicates the effective load center is outside the backface of the cone.
 ▲ For additional "B" cup dimensions, see pages 173 to 174.
 ■ For parts with a "J" prefix, use metric tolerances given on page 199 and fitting practice given on page 201.
 ★ Designate bearings with hollow rollers and pinned-type retainers.
 ◆ Bearing is equipped with seals (and in some instances side rings).

Basic Load Ratings		Axial Load Factor $e Y_2$	Cone Number	B	W_f	R	a	U	V	Cup Number	D	W_o	r	X	Z	W
Dynamic C_r	Static C_{or}			Bore Diameter	Cone Width	Maximum Shaft Fillet Radius [*]	Effective Load Center †	Minimum Shaft Shoulder Diameter	Minimum Shaft Shoulder Diameter		Outside Diameter	Cup Width	Maximum Housing Fillet Radius [*]	Maximum Housing Shoulder Diameter	Maximum Housing Shoulder Diameter	Bearing Width
lbs/N				Inch/mm						Inch/mm						
39000 173000	48000 213000	0.87 0.69	78000C Series													
			78214C	2.1250 53.975	1.3085 33.236	0.03 0.8	0.33 8.4	3.11 79.0	3.05 77.0	78537	5.3750 136.525	0.9260 23.520	0.13 3.3	5.12 130.0	4.53 115.0	1.4375 36.512
			78215C	2.1250 53.975	1.3085 33.236	0.14 3.5	0.33 8.4	3.31 84.0	3.05 77.0	78551	5.5130 140.030	0.9260 23.520	0.09 2.3	5.20 132.0	4.61 117.0	1.4375 36.512
			78225C	2.2500 57.150	1.3085 33.236	0.14 3.5	0.33 8.4	3.39 86.0	3.05 77.0							
			78238C	2.3750 60.325	1.3085 33.236	0.20 5.0	0.33 8.4	3.62 92.0	3.19 81.0							
			78250C	2.5000 63.500	1.3085 33.236	0.09 2.3	0.33 8.4	3.54 90.0	3.31 84.0							
			78250AC	2.5000 63.500	1.3085 33.236	0.20 5.0	0.33 8.4	3.78 96.0	3.31 84.0							
121000 540000	290000 1290000	0.32 1.88	80000 Series													
			80170	17.0000 431.800	1.7500 44.450	0.13 3.3	1.08 27.5	17.64 448.0	17.28 439.0	80217	21.7500 552.450	1.2500 31.750	0.13 3.3	21.42 544.0	21.14 537.0	1.7499 44.448
			80176	17.6250 447.675	1.7500 44.450	0.13 3.3	1.08 27.5	18.27 464.0	17.91 455.0	80222	22.2500 565.150	1.2500 31.750	0.13 3.3	21.89 556.0	21.61 549.0	1.7499 44.448
			80180	18.0000 457.200	1.7500 44.450	0.13 3.3	1.08 27.5	18.62 473.0	18.31 465.0							
74000 330000	114000 505000	0.35 1.71	81000 Series													
			81575	5.7500 146.050	1.9687 50.005	0.14 3.5	-0.21 -5.3	6.42 163.0	6.06 154.0	81962	9.6250 244.475	1.3125 33.338	0.13 3.3	9.45 240.0	9.06 230.0	1.8750 47.625
			81590	5.9055 150.000	1.9687 50.005	0.14 3.5	-0.21 -5.3	6.57 167.0	6.22 158.0							
			81593	5.9375 150.812	1.9687 50.005	0.14 3.5	-0.21 -5.3	6.61 168.0	6.62 158.0							
			81600	6.0000 152.400	1.9687 50.005	0.14 3.5	-0.21 -5.3	6.50 165.0	6.30 160.0							
			81606	6.0625 153.988	1.9687 50.005	0.14 3.5	-0.21 -5.3	6.73 171.0	6.38 162.0							
97000 430000	162000 720000	0.44 1.36	82000 Series													
			82550	5.5000 139.700	2.2300 56.642	0.14 3.5	-0.14 -3.6	6.34 161.0	6.06 154.0	82931	9.3125 236.538	1.7500 44.450	0.13 3.3	8.90 226.0	8.39 213.0	2.2500 57.150
			82562	5.6250 142.875	2.2300 56.642	0.14 3.5	-0.14 -3.6	6.30 160.0	6.14 156.0	82950	9.5000 241.300	1.7500 44.450	0.13 3.3	8.90 226.0	8.46 215.0	2.2500 57.150
			82562A	5.6250 142.875	2.2300 56.642	0.31 8.0	-0.14 -3.6	6.81 173.0	6.18 157.0	▲ 82950B	9.5000 241.300	1.7500 44.450	0.13 3.3	8.90 226.0	—	2.2500 57.150
			82576	5.7500 146.050	2.2300 56.642	0.14 3.5	-0.14 -3.6	6.54 166.0	6.30 160.0							
			82587	5.8750 149.225	2.2300 56.642	0.14 3.5	-0.14 -3.6	6.73 171.0	6.46 164.0							

* The maximum fillet on the shaft or in the housing that the bearing corner will clear.

† Positive value indicates the effective load center is outside the backface of the cone.

▲ For additional "B" cup dimensions, see pages 173 to 174.

■ For parts with a "J" prefix, use metric tolerances given on page 199 and fitting practice given on page 201.

★ Designate bearings with hollow rollers and pinned-type retainers.

◆ Bearing is equipped with seals (and in some instances side rings).

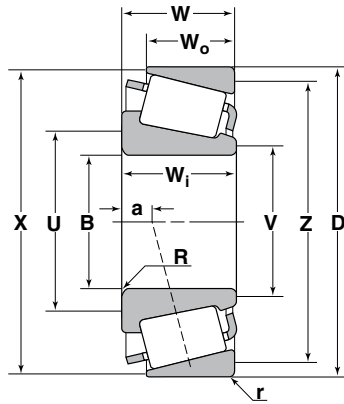

TS Type

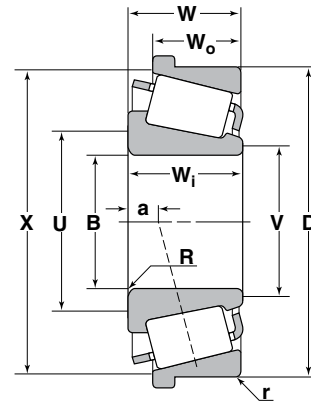

TSF Type

Basic Load Ratings		Axial Load Factor e Y_2	Cone Number	B	W_i	R	a	U	V	Cup Number	D	W_o	r	X	Z	W
Dynamic C_r	Static C_{or}			Bore Diameter	Cone Width	Maximum Shaft Fillet Radius †	Effective Load Center †	Minimum Shaft Shoulder Diameter	Minimum Shaft Shoulder Diameter		Outside Diameter	Cup Width	Maximum Housing Fillet Radius †	Maximum Housing Shoulder Diameter	Maximum Housing Shoulder Diameter	Bearing Width
lbs/N				Inch/mm						Inch/mm						
79500 355000	133000 595000	0.42 1.44	87000 Series													
			87737	7.3750 187.325	1.8750 47.625	0.14 3.5	0.15 3.8	8.15 207.0	7.91 201.0	87111	11.1250 282.575	1.4375 36.512	0.13 3.3	10.50 267.0	10.28 261.0	2.0000 50.800
			87750	7.5000 190.500	1.8750 47.625	0.14 3.5	0.15 3.8	8.23 209.0	7.99 203.0	▲ 87111B	11.1250 282.575	1.4375 36.512	0.13 3.3	10.71 10.7	—	2.0000 50.800
			87762	7.6250 193.675	1.8750 47.625	0.14 3.5	0.15 3.8	8.31 211.0	8.11 206.0							
88000 390000	161000 715000	0.49 1.23	88000 Series													
			88900	9.0000 228.600	1.9375 49.212	0.25 6.4	0.56 14.2	9.96 253.0	9.53 242.0	88126	12.6250 320.675	1.3125 33.338	0.13 3.3	12.17 309.0	11.77 299.0	2.0000 50.800
			88925	9.2500 234.950	1.9375 49.212	0.25 6.4	0.56 14.2	10.16 258.0	9.69 246.0	88128	12.8750 327.025	1.3750 34.925	0.13 3.3	12.17 309.0	11.89 302.0	2.0625 52.388
			88931	9.3125 236.538	1.7500 44.450	0.14 3.5	0.81 20.6	10.16 258.0	9.69 246.0	88126	12.6250 320.675	1.3125 33.338	0.13 3.3	12.17 309.0	11.77 299.0	1.7500 44.450
			88128	12.8750 327.025	1.3750 34.925	0.13 3.3	12.17 309.0	11.89 302.0	1.8125 46.038	88128	12.8750 327.025	1.3750 34.925	0.13 3.3	12.17 309.0	11.89 302.0	1.8125 46.038
61000 271000	78000 345000	0.87 0.69	90000 Series													
			90334	3.3465 85.000	2.0772 52.761	0.14 3.5	0.41 10.4	4.57 116.0	4.41 112.0	90744	7.4375 188.912	1.2500 31.750	0.13 3.3	7.06 179.0	6.34 161.0	2.0983 53.297
			■ J90354	3.5433 90.000	1.8125 46.038	0.14 3.5	0.50 12.7	4.72 120.0	4.40 112.0	■ J90748	7.4803 190.000	1.2500 31.750	0.13 3.3	7.06 179.0	6.38 162.0	2.0983 53.297
			90381	3.8125 96.838	1.8125 46.038	0.14 3.5	0.50 12.7	4.92 125.0	4.44 113.0	90744	7.4375 188.912	1.2500 31.750	0.13 3.3	7.06 179.0	6.34 161.0	2.0000 50.800
			■ J90748	7.4803 190.000	1.2500 31.750	0.13 3.3	7.06 179.0	6.38 162.0	2.0000 50.800	■ J90748	7.4803 190.000	1.2500 31.750	0.13 3.3	7.06 179.0	6.38 162.0	2.0000 50.800

* The maximum fillet on the shaft or in the housing that the bearing corner will clear.
 † Positive value indicates the effective load center is outside the backface of the cone.
 ▲ For additional "B" cup dimensions, see pages 173 to 174.
 ■ For parts with a "J" prefix, use metric tolerances given on page 199 and fitting practice given on page 201.
 ★ Designate bearings with hollow rollers and pinned-type retainers.
 ◆ Bearing is equipped with seals (and in some instances side rings).

Basic Load Ratings		Axial Load Factor e Y_2	Cone Number	B	W_i	R	a	U	V	Cup Number	D	W_o	r	X	Z	W
Dynamic C_r	Static C_{or}			Bore Diameter	Cone Width	Maximum Shaft Fillet Radius *	Effective Load Center†	Minimum Shaft Shoulder Diameter	Minimum Shaft Shoulder Diameter		Outside Diameter	Cup Width	Maximum Housing Fillet Radius *	Maximum Housing Shoulder Diameter	Maximum Housing Shoulder Diameter	Bearing Width
lbs/N				Inch/mm								Inch/mm				
135000 600000	251000 1120000	0.52 1.15	93000 Series													
			93708	7.0856 179.974	2.5000 63.500	0.14 3.5	0.31 7.9	8.23 209.0	8.03 204.0	93125	12.5000 317.500	1.8125 46.038	0.13 3.3	11.81 300.0	11.26 286.0	2.5000 63.500
			93750	7.5000 190.500	2.5000 63.500	0.17 4.3	0.31 7.9	8.58 218.0	8.35 212.0	▲ 93125B	12.5000 317.500	1.8125 46.038	0.13 3.3	11.81 300.0	— —	2.5000 63.500
			93775	7.7500 196.850	2.5000 63.500	0.17 4.3	0.31 7.9	8.54 217.0	8.07 205.0							
			93787	7.8750 200.025	2.5000 63.500	0.17 4.3	0.31 7.9	8.86 225.0	8.62 219.0							
			93800	8.0000 203.200	2.5000 63.500	0.17 4.3	0.31 7.9	8.94 227.0	8.74 222.0							
			93825	8.2500 209.550	2.5000 63.500	0.17 4.3	0.31 7.9	9.17 233.0	8.93 227.0							
			93825A	8.2500 209.550	2.5000 63.500	0.50 12.7	0.31 7.9	10.39 264	8.54 217.0							
121000 535000	207000 925000	0.47 1.28	94000 Series													
			94649	6.5000 165.100	2.5000 63.500	0.28 7.0	-0.03 -0.8	7.76 197.0	7.32 186.0	94113	11.3750 288.925	1.8750 47.625	0.13 3.3	10.71 272.0	10.20 259.0	2.5000 63.500
			94650	6.5000 165.100	2.5000 63.500	0.28 7.0	-0.03 -0.8	7.76 197.0	— —	▲ 94113B	11.3750 288.925	1.8750 47.625	0.13 3.3	10.71 272.0	— —	2.5000 63.500
			94687	6.8750 174.625	2.5000 63.500	0.28 7.0	-0.03 -0.8	8.03 204.0	7.60 193.0							
			94700	7.0000 177.800	2.5000 63.500	0.28 7.0	-0.03 -0.8	8.15 207.0	7.68 195.0							
114000 510000	179000 795000	0.37 1.62	95000 Series													
			95475	4.7500 120.650	2.5000 63.500	0.25 6.4	-0.55 -14.0	5.87 149.0	5.39 137.0	95905	9.0551 230.000	1.9375 49.212	0.13 3.3	8.54 217.0	8.15 207.0	2.5000 63.500
			95491	4.9190 124.943	2.5000 63.500	0.25 6.4	-0.55 -14.0	6.02 153.0	5.43 138.0	95925	9.2500 234.950	1.9375 49.212	0.13 3.3	8.54 217.0	8.23 209.0	2.5000 63.500
			95500	5.0000 127.000	2.5000 63.500	0.25 6.4	-0.55 -14.0	6.06 154.0	5.59 142.0	▲ 95925B	9.2500 234.950	1.9375 49.212	0.13 3.3	8.54 217.0	— —	2.5000 63.500
			95525	5.2500 133.350	2.5000 63.500	0.38 9.7	-0.55 -14.0	6.54 166.0	5.83 148.0	95975	9.7500 247.650	1.9375 49.212	0.13 3.3	9.53 242.0	9.13 232.0	2.5000 63.500
			95528	5.2500 133.350	2.5000 63.500	0.19 4.8	-0.55 -14.0	6.18 157.0	5.83 148.0							

- * The maximum fillet on the shaft or in the housing that the bearing corner will clear.
- † Positive value indicates the effective load center is outside the backface of the cone.
- ▲ For additional "B" cup dimensions, see pages 173 to 174.
- For parts with a "J" prefix, use metric tolerances given on page 199 and fitting practice given on page 201.
- ★ Designate bearings with hollow rollers and pinned-type retainers.
- ◆ Bearing is equipped with seals (and in some instances side rings).

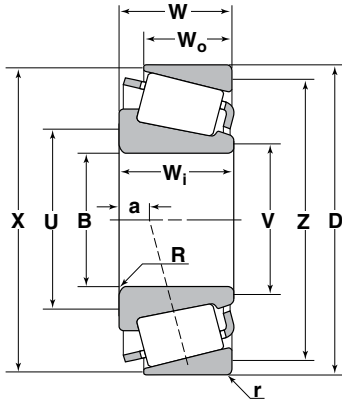

TS Type

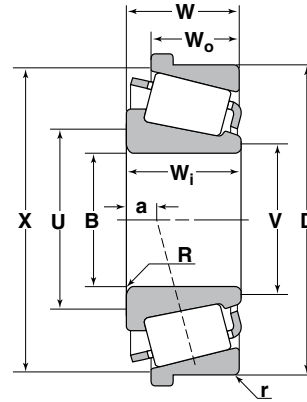

TSF Type

Basic Load Ratings		Axial Load Factor e Y_2	Cone Number	B	W_i	R	a	U	V	Cup Number	D	W_o	r	X	Z	W
Dynamic C_r	Static C_{or}			Bore Diameter	Cone Width	Maximum Shaft Fillet Radius †	Effective Load Center†	Minimum Shaft Shoulder Diameter	Minimum Shaft Shoulder Diameter		Outside Diameter	Cup Width	Maximum Housing Fillet Radius *	Maximum Housing Shoulder Diameter	Maximum Housing Shoulder Diameter	Bearing Width
lbs/N				Inch/mm						Inch/mm						
141000 625000	276000 1230000	0.59 1.02	96000 Series													
			96825	8.2500 209.550	2.6250 66.675	0.28 7.0	0.67 17.0	9.49 241.0	8.58 218.0	96140	14.0000 355.600	1.8750 47.625	0.13 3.3	13.15 334.0	12.52 318.0	2.6875 68.262
			96900	9.0000 228.600	2.6250 66.675	0.28 7.0	0.67 17.0	10.24 260.0	9.80 249.0	▲ 96140B	14.0000 355.600	1.8750 47.625	0.13 3.3	13.15 334.0	—	2.6875 68.262
			96925	9.2500 234.950	2.6250 66.675	0.28 7.0	0.67 17.0	10.43 265.0	10.00 254.0							
75500 335000	101000 450000	0.63 0.95	98000 Series													
			98316	3.1496 80.000	1.9375 49.212	0.14 3.5	0.05 1.3	4.37 111.0	4.13 105.0	98788	7.8740 200.000	1.3750 34.925	0.13 3.3	7.40 188.0	6.85 174.0	2.0772 52.761
			98335	3.3465 85.000	1.9375 49.212	0.14 3.5	0.05 1.3	4.53 115.0	4.29 109.0	▲ 98788B	7.8740 200.000	1.3750 34.925	0.13 3.3	7.40 188.0	—	2.0772 52.761
			98350	3.5000 88.900	1.9375 49.212	0.14 3.5	0.05 1.3	4.65 118.0	4.41 112.0							
			98400	4.0000 101.600	1.9375 49.212	0.14 3.5	0.05 1.3	5.04 128.0	4.75 121.0							

* The maximum fillet on the shaft or in the housing that the bearing corner will clear.
 † Positive value indicates the effective load center is outside the backface of the cone.
 ▲ For additional "B" cup dimensions, see pages 173 to 174.
 ■ For parts with a "J" prefix, use metric tolerances given on page 199 and fitting practice given on page 201.
 ★ Designate bearings with hollow rollers and pinned-type retainers.
 ◆ Bearing is equipped with seals (and in some instances side rings).

Basic Load Ratings		Axial Load Factor $e Y_2$	Cone Number	B	W_1	R	a	U	V	Cup Number	D	W_0	r	X	Z	W
Dynamic C_r	Static C_{or}			Bore Diameter	Cone Width	Maximum Shaft Fillet Radius \dagger	Effective Load Center \dagger	Minimum Shaft Shoulder Diameter	Minimum Shaft Shoulder Diameter		Outside Diameter	Cup Width	Maximum Housing Fillet Radius \dagger	Maximum Housing Shoulder Diameter	Maximum Housing Shoulder Diameter	Bearing Width
lbs/N				Inch/mm									Inch/mm			
120000 535000	197000 880000	0.41 1.47	99000 Series													
			99500	5.0000 127.000	2.6250 66.675	0.28 7.0	-0.48 -12.2	6.22 158.0	5.31 135.0	99100	10.0000 254.000	1.8750 47.625	0.13 3.3	9.37 238.0	8.94 227.0	2.6250 66.675
			99550	5.5000 139.700	2.6250 66.675	0.28 7.0	-0.48 -12.2	6.69 170.0	6.14 156.0	▲ 99100B	10.0000 254.000	1.8750 47.625	0.13 3.3	9.37 238.0	— —	2.6250 66.675
			99575	5.7500 146.050	2.6250 66.675	0.28 7.0	-0.48 -12.2	6.89 175.0	6.38 162.0							
			99587	5.8750 149.225	2.6250 66.675	0.28 7.0	-0.48 -12.2	7.01 178.0	6.50 165.0							
			99600	6.0000 152.400	2.6250 66.675	0.28 7.0	-0.48 -12.2	7.13 181.0	6.68 170.0							
15700 69500	21100 94000	1.97	LM104900 Series													
			LM104947A	1.9680 49.987	0.8750 22.225	0.02 0.5	-0.23 -5.8	2.17 55.0	2.17 55.0	■ JLM104910	3.2283 82.000	0.6693 17.000	0.02 0.5	3.07 78.0	2.99 76.0	0.8652 21.976
			LM104949	2.0000 50.800	0.8750 22.225	0.14 3.5	-0.23 -5.8	2.44 62.0	2.17 55.0	LM104911	3.2500 82.550	0.6500 16.510	0.05 1.3	3.07 78.0	2.95 75.0	0.8500 21.590
										LM104912	3.2650 82.931	0.6500 16.510	0.05 1.3	3.07 78.0	2.95 75.0	0.8500 21.590
			■ JLM104948	1.9685 50.000	0.8465 21.500	0.12 3.0	-0.21 -5.3	2.36 60.0	2.17 55.0	■ JLM104910	3.2283 82.000	0.6693 17.000	0.02 0.5	3.07 78.0	2.99 76.0	0.8465 21.500
										LM104911	3.2500 82.550	0.6500 16.510	0.05 1.3	3.07 78.0	2.95 75.0	0.8313 21.115
										LM104912	3.2650 82.931	0.6500 16.510	0.05 1.3	3.07 78.0	2.95 75.0	0.8313 21.115
148000 660000	236000 1050000	0.39 1.55	107000 Series													
			EE107057	5.7500 146.050	2.9375 74.612	0.25 6.4	-0.59 -15.0	6.93 176.0	6.54 166.0	107105	10.5625 268.288	2.2500 57.150	0.25 6.4	9.82 249.0	9.33 237.0	2.9375 74.612
			EE107060	6.0000 152.400	2.9375 74.612	0.25 6.4	-0.59 -15.0	7.13 181.0	6.73 171.0							
38000 168000	69500 310000	0.28 2.15	LM122900 Series													
			LM122948	4.5000 114.300	1.3750 34.925	0.13 3.3	-0.22 -5.6	5.12 130.0	4.80 122.0	LM122911	6.2500 158.750	1.1875 30.162	0.13 3.3	6.10 155.0	5.63 143.0	1.3750 34.925
168000 745000	310000 1370000	0.34 1.75	125000 Series													
			EE125094	9.4930 241.122	2.6875 68.262	0.25 6.4	-0.19 -5.1	10.59 269.0	9.72 247.0	125145	14.5000 368.300	2.1250 53.975	0.13 3.3	14.29 363.0	13.86 352.0	2.6875 68.262
			EE125095	9.5000 241.300	2.6875 68.262	0.25 6.4	-0.19 -5.1	10.63 270.0	9.72 247.0							

* The maximum fillet on the shaft or in the housing that the bearing corner will clear.
† Positive value indicates the effective load center is outside the backface of the cone.
▲ For additional "B" cup dimensions, see pages 173 to 174.
■ For parts with a "J" prefix, use metric tolerances given on page 199 and fitting practice given on page 201.
★ Designate bearings with hollow rollers and pinned-type retainers.
◆ Bearing is equipped with seals (and in some instances side rings).

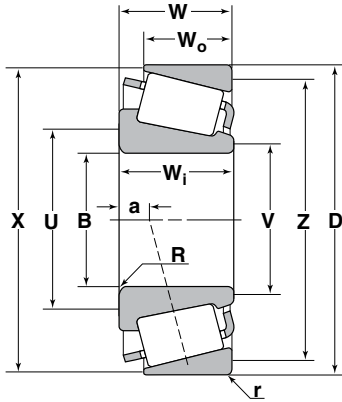

TS Type

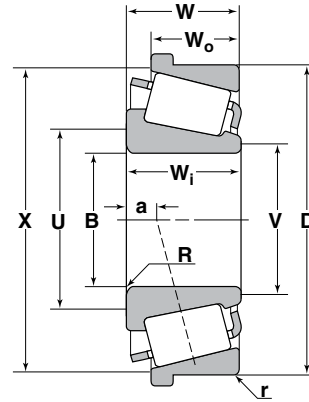

TSF Type

Basic Load Ratings		Axial Load Factor e Y_2	Cone Number	B	W_i	R	a	U	V	Cup Number	D	W_o	r	X	Z	W
Dynamic C_r	Static C_{or}			Bore Diameter	Cone Width	Maximum Shaft Fillet Radius †	Effective Load Center†	Minimum Shaft Shoulder Diameter	Minimum Shaft Shoulder Diameter		Outside Diameter	Cup Width	Maximum Housing Fillet Radius *	Maximum Housing Shoulder Diameter	Maximum Housing Shoulder Diameter	Bearing Width
lbs/N				Inch/mm						Inch/mm						
129000 575000	242000 1080000	0.35 1.70	127000 Series													
			EE127095	9.5000 241.300	2.2500 57.150	0.25 6.4	0.10 2.5	10.51 267.0	10.12 257.0	127135	13.7460 349.148	1.7500 44.450	0.13 3.3	12.95 329.0	12.80 325.0	2.2500 57.150
										127138	13.9960 355.498	1.7500 44.450	0.13 3.3	12.95 329.0	12.80 325.0	2.2500 57.150
84000 375000	142000 630000	0.26 2.27	HM127400 Series													
			HM127436	4.7227 119.957	2.2500 57.150	0.06 1.5	-0.56 -14.2	5.08 129.0	5.04 128.0	HM127415	8.1875 207.962	1.7500 44.450	0.13 3.3	7.91 201.0	7.56 192.0	2.1250 53.975
			HM127440	4.9995 126.987	2.2500 57.150	0.06 1.5	-0.56 -14.2	5.35 136.0	5.31 135.0							
			HM127442	5.1168 129.967	2.2500 57.150	0.06 1.5	-0.56 -14.2	5.47 139.0	5.43 138.0							
			HM127446	5.1870 131.750	2.2500 57.150	0.06 1.5	-0.56 -14.2	5.51 140.0	5.47 139.0							
206000 915000	400000 1780000	0.39 1.55	128000 Series													
			EE128111	11.0312 280.192	2.6643 67.673	0.27 6.8	0.26 6.6	12.17 309.0	12.09 307.0	128160	16.0000 406.400	2.1250 53.975	0.13 3.3	15.12 384.0	14.88 378.0	2.7500 69.850
			EE128112	11.0236 280.000	2.6643 67.673	0.25 6.4	0.26 6.6	12.13 308.0	12.09 307.0	▲ 128160B	16.0000 406.400	2.1250 53.975	0.13 3.3	15.12 384.0	— —	2.7500 69.850
237000 1060000	435000 1930000	0.31 1.95	HM150100 Series													
			HM150144	9.7500 247.650	3.2500 82.550	0.25 6.4	-0.53 -13.5	10.87 276.0	10.04 255.0	HM150113	15.0000 381.000	2.7500 69.850	0.13 3.3	14.65 372.0	14.37 365.0	3.2500 82.550

* The maximum fillet on the shaft or in the housing that the bearing corner will clear.

† Positive value indicates the effective load center is outside the backface of the cone.

▲ For additional "B" cup dimensions, see pages 173 to 174.

■ For parts with a "J" prefix, use metric tolerances given on page 199 and fitting practice given on page 201.

★ Designate bearings with hollow rollers and pinned-type retainers.

◆ Bearing is equipped with seals (and in some instances side rings).

Basic Load Ratings		Axial Load Factor e Y ₂	Cone Number	B	W ₁	R	a	U	V	Cup Number	D	W ₀	r	X	Z	W
Dynamic C _r	Static C _{or}			Bore Diameter	Cone Width	Maximum Shaft Fillet Radius †	Effective Load Center†	Minimum Shaft Shoulder Diameter	Minimum Shaft Shoulder Diameter		Outside Diameter	Cup Width	Maximum Housing Fillet Radius †	Maximum Housing Shoulder Diameter	Maximum Housing Shoulder Diameter	Maximum Housing Shoulder Diameter
lbs/N			Inch/mm							Inch/mm						
425000 1890000	805000 3600000	0.31 1.95	HM162600 Series													
			HM162635	12.5000 317.500	4.0000 101.600	0.25 6.4	-0.54 -13.7	13.62 346.0	12.80 325.0	HM162610	20.0000 508.000	3.2500 82.550	0.13 3.3	19.80 503.0	19.37 492.0	4.0625 103.187
			HM162649	13.6250 346.075	4.0000 101.600	0.25 6.4	-0.25 -13.7	14.72 374.0	13.94 354.0							
146000 650000	385000 1720000	0.31 1.95	L163100 Series													
			L163149	14.0000 355.600	2.3750 60.325	0.14 3.5	0.28 7.1	14.72 374.0	14.57 370.0	L163110	17.5000 444.500	1.8750 47.625	0.13 3.3	16.93 430.0	16.61 422.0	2.3750 60.325
585000 2590000	1230000 5450000	0.29 2.05	HM168600 Series													
			HM168649	16.3750 415.925	5.0000 127.000	0.25 6.4	-0.89 -22.6	17.48 444.0	16.69 424.0	HM168610	23.2500 590.550	4.0000 101.600	0.25 6.4	22.91 582.0	22.13 562.0	5.0000 127.000
41000 182000	54500 243000	0.34 1.78	H211700 Series													
			■ JH211749	2.5591 65.000	1.5157 38.500	0.12 3.0	-0.42 -10.7	3.15 80.0	2.91 74.0	■ JH211710	4.7244 120.000	1.2598 32.000	0.10 2.5	4.49 114.0	4.21 107.0	1.5354 39.000
			■ JH211749A	2.5591 65.000	1.5157 38.500	0.28 7.0	-0.42 -10.7	3.46 88.0	2.91 74.0							
42000 186000	54500 243000	0.34 1.78	HM212000 Series													
			HM212044	2.3750 60.325	1.5100 38.354	0.31 8.0	-0.43 -10.9	3.35 85.0	2.76 70.0	HM212010	4.8125 122.238	1.1700 29.718	0.06 1.5	4.57 116.0	4.33 110.0	1.5000 38.100
			HM212046	2.5000 63.500	1.5100 38.354	0.14 3.5	-0.43 -10.9	3.15 80.0	2.87 73.0	HM212011	4.8125 122.238	1.1700 29.718	0.13 3.3	4.57 116.0	4.25 108.0	1.5000 38.100
			HM212047	2.5000 63.500	1.5100 38.354	0.28 7.0	-0.43 -10.9	3.43 87.0	2.87 73.0							
			HM212049	2.6250 66.675	1.5100 38.354	0.14 3.5	-0.43 -10.9	3.23 82.0	2.97 75.0							
			HM212049A	2.6250 66.675	1.5100 38.354	0.22 5.6	-0.43 -10.9	3.50 89.0	2.97 75.0							
			HM212049X	2.6250 66.675	1.5100 38.354	0.28 7.0	-0.43 -10.9	3.50 89.0	2.97 75.0							
60000 268000	85000 380000	0.33 1.80	H217200 Series													
			■ JH217249	3.3465 85.000	1.8110 46.000	0.12 3.0	-0.47 -11.9	3.98 101.0	3.74 95.0	■ JH217210	5.9055 150.000	1.4961 38.000	0.10 2.5	5.59 142.0	5.28 134.0	1.8110 46.000
11700 52000	18000 80000	0.33 1.81	LL217800 Series													
			LL217849	3.5000 88.900	0.5938 15.083	0.06 1.5	0.12 3.0	3.82 97.0	3.70 94.0	LL217810	4.7812 121.442	0.4375 11.112	0.06 1.5	4.61 117.0	4.53 115.0	0.5938 15.083
51000 226000	765000 340000	0.33 1.80	HM218200 Series													
			HM218238	3.1486 79.974	1.5748 40.000	0.28 7.0	-0.34 -8.6	4.09 104.0	3.58 91.0	HM218210	5.7864 146.975	1.2795 32.500	0.14 3.5	5.55 141.0	5.24 133.0	1.5748 40.000
			HM218248	3.5423 89.974	1.5748 40.000	0.28 7.0	-0.34 -8.6	4.41 112.0	3.90 99.0	HM218215	6.0000 152.400	1.2795 32.500	0.13 3.3	5.63 143.0	5.31 135.0	1.5748 40.000

* The maximum fillet on the shaft or in the housing that the bearing corner will clear.

† Positive value indicates the effective load center is outside the backface of the cone.

▲ For additional "B" cup dimensions, see pages 173 to 174.

■ For parts with a "J" prefix, use metric tolerances given on page 199 and fitting practice given on page 201.

★ Designate bearings with hollow rollers and pinned-type retainers.

◆ Bearing is equipped with seals (and in some instances side rings).

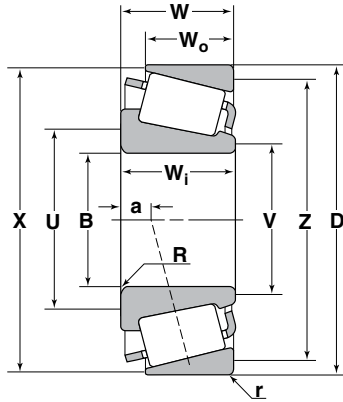

TS Type

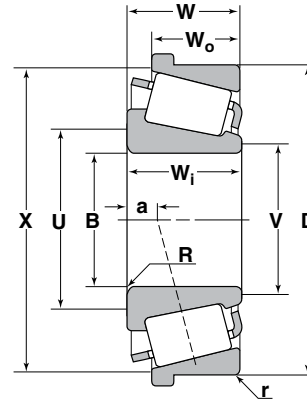

TSF Type

Basic Load Ratings		Axial Load Factor e Y_2	Cone Number	B	W_i	R	a	U	V	Cup Number	D	W_o	r	X	Z	W
Dynamic C_r	Static C_{or}			Bore Diameter	Cone Width	Maximum Shaft Fillet Radius †	Effective Load Center †	Minimum Shaft Shoulder Diameter	Minimum Shaft Shoulder Diameter		Outside Diameter	Cup Width	Maximum Housing Fillet Radius †	Maximum Housing Shoulder Diameter	Maximum Housing Shoulder Diameter	Bearing Width
lbs/N				Inch/mm						Inch/mm						
170000 755000	272000 1210000	0.38 1.59	219000 Series													
			EE219068	6.8750 174.625	3.2500 82.550	0.25 6.4	-0.60 -15.2	8.03 204.0	7.60 193.0	219117	11.7500 298.450	2.5000 63.500	0.25 6.4	11.10 282.0	10.59 269.0	3.2500 82.550
										219122	12.2500 311.150	2.5000 63.500	0.25 6.4	11.10 282.0	10.83 275.0	3.2500 82.550
56000 249000	86000 380000	0.33 1.80	HM220100 Series													
			HM220145	3.9360 99.974	2.0669 52.500	0.31 8.0	-0.35 -8.9	5.31 135.0	4.25 108.0	HM220110	6.1801 156.975	1.3386 34.000	0.14 3.5	5.94 151.0	5.51 140.0	1.6535 42.000
			HM220149	3.9360 99.974	1.6535 42.000	0.31 8.0	-0.35 -8.9	5.31 135.0	4.25 108.0							
97000 430000	132000 590000	0.33 1.79	HH221400 Series													
			HH221430	3.0000 76.200	2.2650 57.531	0.14 3.5	-0.59 -15.0	3.98 101.0	3.74 95.0	HH221410	7.5000 190.500	1.8125 46.038	0.13 3.3	7.05 179.0	6.73 171.0	2.2500 57.150
			HH221431	3.1250 79.375	2.2650 57.531	0.14 3.5	-0.59 -15.0	4.06 103.0	3.82 97.0	▲ HH221410B	7.5000 190.500	1.8125 46.038	0.13 3.3	7.05 179.0	— —	2.2500 57.150
			HH221434	3.5000 88.900	2.2650 57.531	0.31 8.0	-0.59 -15.0	4.72 120.0	4.13 105.0	■ JHH221413	7.4803 190.000	1.8125 46.038	0.13 3.3	7.28 185.0	6.73 171.0	2.2500 57.150
			■ JHH221436	3.5433 90.000	2.2650 57.531	0.31 8.0	-0.59 -15.0	4.76 121.0	4.17 106.0							
			HH221440	3.7500 95.250	2.2650 57.531	0.31 8.0	-0.59 -15.0	4.92 125.0	4.33 110.0							
			HH221442	3.8750 98.425	2.2650 57.531	0.14 3.5	-0.59 -15.0	4.69 119.0	4.45 113.0							
			HH221447	3.9363 99.982	2.2650 57.531	0.25 6.4	-0.59 -15.0	4.96 126.0	4.49 114.0							
			HH221449	4.0000 101.600	2.2650 57.531	0.31 8.0	-0.59 -15.0	5.16 131.0	4.56 116.0							
			HH221449A	4.0000 101.600	2.2650 57.531	0.14 3.5	-0.59 -15.0	4.80 122.0	4.56 116.0							

- * The maximum fillet on the shaft or in the housing that the bearing corner will clear.
- † Positive value indicates the effective load center is outside the backface of the cone.
- ▲ For additional "B" cup dimensions, see pages 173 to 174.
- For parts with a "J" prefix, use metric tolerances given on page 199 and fitting practice given on page 201.
- ★ Designate bearings with hollow rollers and pinned-type retainers.
- ◆ Bearing is equipped with seals (and in some instances side rings).

Basic Load Ratings		Axial Load Factor e Y ₂	Cone Number	B	W ₁	R	a	U	V	Cup Number	D	W ₀	r	X	Z	W
Dynamic C _r	Static C _{or}			Bore Diameter	Cone Width	Maximum Shaft Fillet Radius *	Effective Load Center†	Minimum Shaft Shoulder Diameter	Minimum Shaft Shoulder Diameter		Outside Diameter	Cup Width	Maximum Housing Fillet Radius *	Maximum Housing Shoulder Diameter	Maximum Housing Shoulder Diameter	Bearing Width
lbs/N				Inch/mm								Inch/mm				
123000 545000	172000 765000	0.33 1.84	HH224300 Series													
			■ JHH224333	3.9370 100.000	2.6250 66.675	0.28 7.0	-0.74 -18.8	5.16 131.0	4.72 120.0	HH224310	8.3750 212.725	2.1250 53.975	0.13 3.3	7.94 202.0	7.56 192.0	2.6250 66.675
			HH224334	3.9360 99.974	2.6250 66.675	0.14 3.5	-0.74 -18.8	4.88 124.0	4.72 120.0	HH224314	8.4636 214.975	2.0000 50.800	0.13 3.3	8.31 211.0	7.83 199.0	2.5511 64.797
			HH224335	4.0000 101.600	2.6250 66.675	0.28 7.0	-0.74 -18.8	5.20 132.0	4.76 121.0	■ JHH224315	8.4646 215.000	2.1250 53.975	0.13 3.3	7.94 202.0	7.60 193.0	2.6250 66.675
			HH224340	4.2500 107.950	2.6250 66.675	0.31 8.0	-0.74 -18.8	5.47 139.0	4.96 126.0							
			HH224346	4.5000 114.300	2.6250 66.675	0.28 7.0	-0.74 -18.8	5.63 143.0	5.16 131.0							
			HH224346A	4.5000 114.300	2.6250 66.675	0.50 12.7	-0.74 -18.8	5.71 145.0	5.16 131.0							
			HH224349	4.5266 114.976	2.6250 66.675	0.28 7.0	-0.74 -18.8	5.67 144.0	5.16 131.0							
46000 205000	83000 370000	0.33 1.80	M224700 Series													
			M224749	4.7500 120.650	1.4375 36.512	0.14 3.5	-0.14 -3.6	5.31 135.0	5.08 129.0	M224710	6.8750 174.625	1.0938 27.783	0.06 1.5	6.61 168.0	6.42 163.0	1.4063 35.720
										M224711	6.7812 172.242	1.0938 27.783	0.06 1.5	6.57 167.0	6.38 162.0	1.4063 35.720
17800 79500	31000 138000	0.33 1.80	LL225700 Series													
			LL225749	5.0000 127.000	0.6875 17.462	0.06 1.5	0.24 6.1	5.31 135.0	5.24 133.0	LL225710	6.5313 165.895	0.5313 13.495	0.06 1.5	6.30 160.0	6.22 158.0	0.7188 18.258
28600 127000	58000 257000	0.33 1.80	L225800 Series													
			L225842	4.7500 120.650	1.0313 26.195	0.06 1.5	0.10 2.5	5.16 131.0	5.08 129.0	L225810	6.6875 169.862	0.8125 20.638	0.06 1.5	6.46 164.0	6.30 160.0	1.0000 25.400
			L225849	5.0000 127.000	1.0313 26.195	0.06 1.5	0.10 2.5	5.35 136.0	5.28 134.0	L225818	7.1250 180.975	0.8125 20.638	0.06 1.5	6.54 166.0	6.46 164.0	1.0000 25.400
163000 725000	234000 1040000	0.32 1.87	HH228300 Series													
			HH228340	4.7500 120.650	3.2500 82.500	0.38 9.7	-0.92 -23.4	6.22 158.0	5.59 142.0	HH228310	10.0000 254.000	2.4375 61.912	0.25 6.4	9.20 234.0	8.78 223.0	3.0625 77.788
			HH228349	5.0000 127.000	3.2500 82.500	0.38 9.7	-0.92 -23.4	6.64 164.0	5.83 148.0							
57000 255000	102000 455000	0.33 1.80	M229300 Series													
			M229349	5.7500 146.050	1.5748 40.000	0.14 3.5	-0.10 -2.5	6.42 163.0	5.98 152.0	M229310	8.0000 203.200	1.5000 38.100	0.14 3.5	7.80 198.0	7.32 186.0	1.7756 45.100
			M229349A	5.7500 146.050	1.5748 40.000	0.20 5.0	-0.10 -2.5	6.65 169.0	5.98 152.0							
203000 900000	410000 1830000	0.44 1.36	230000 Series													
			EE231400	14.0000 355.600	2.6250 66.675	0.25 6.4	0.77 19.6	15.28 388.0	14.92 379.0	231975	19.7500 501.650	2.0000 50.800	0.13 3.3	18.94 481.0	18.58 472.0	2.9375 74.612
			EE231462	14.6250 371.475	2.2650 66.675	0.25 6.4	0.77 19.6	15.75 400.0	15.35 390.0	▲ 23200B	20.0000 508.000	2.0000 50.800	0.13 3.3	19.25 489.0	— —	2.9375 74.612

- * The maximum fillet on the shaft or in the housing that the bearing corner will clear.
- † Positive value indicates the effective load center is outside the backface of the cone.
- ▲ For additional "B" cup dimensions, see pages 173 to 174.
- For parts with a "J" prefix, use metric tolerances given on page 199 and fitting practice given on page 201.
- ★ Designate bearings with hollow rollers and pinned-type retainers.
- ◆ Bearing is equipped with seals (and in some instances side rings).

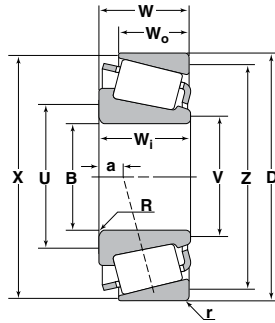

TS Type

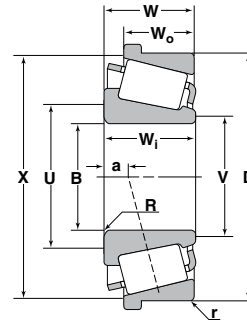

TSF Type

Basic Load Ratings		Axial Load Factor e Y_2	Cone Number	B	W_i	R	a	U	V	Cup Number	D	W_o	r	X	Z	W
Dynamic C_r	Static C_{or}			Bore Diameter	Cone Width	Maximum Shaft Fillet Radius †	Effective Load Center †	Minimum Shaft Shoulder Diameter	Minimum Shaft Shoulder Diameter		Outside Diameter	Cup Width	Maximum Housing Fillet Radius †	Maximum Housing Shoulder Diameter	Maximum Housing Shoulder Diameter	Bearing Width
lbs/N							Inch/mm				Inch/mm					
109000 485000	179000 795000	0.32 1.88	HM231100 Series													
			HM231140	5.7500 146.050	2.2300 56.642	0.14 3.5	-0.45 -11.4	6.46 164.0	6.30 160.0	HM231110	9.3125 236.538	1.7500 44.450	0.13 3.3	8.82 224.0	8.54 217.0	2.2500 57.150
			HM231148	5.8750 149.225	2.2300 56.642	0.25 6.4	-0.45 -11.4	6.77 172.0	6.42 163.0	HM231115	9.5000 241.300	1.7500 44.450	0.13 3.3	8.82 224.0	8.86 225.0	2.2500 57.150
			HM231149	5.8750 149.225	2.2300 56.642	0.14 3.5	-0.45 -11.4	6.57 167.0	6.42 163.0	▲ HM231115B	9.5000 241.300	1.7500 44.450	0.13 3.3	8.82 224.0	— —	2.2500 57.150
69500 310000	129000 570000	0.33 1.80	M231600 Series													
			M231648	6.0000 152.400	1.8437 46.830	0.31 8.0	-0.24 -6.0	7.01 178.0	6.42 163.0	M231610	8.7500 222.250	1.3750 34.925	0.06 1.5	8.39 231.0	8.15 207.0	1.8437 46.830
			M231649	6.0000 152.400	1.8437 46.830	0.14 3.5	-0.24 -6.0	6.65 169.0	6.42 163.0							
228000 1010000	310000 1390000	0.33 1.79	HH234000 Series													
			HH234048	6.0000 152.400	3.6875 93.662	0.38 9.7	-1.04 -26.4	7.64 194.0	6.69 170.0	HH234010	12.1250 307.975	2.6250 66.675	0.27 6.8	11.65 296.0	10.94 278.0	3.5000 88.900
89000 395000	145000 645000	0.32 1.88	M235100 Series													
			M235145	6.5000 165.100	1.8125 46.038	0.19 4.8	-0.18 -4.6	7.28 185.0	7.05 179.0	M235113	10.0000 254.000	1.3125 33.338	0.13 3.3	9.45 240.0	9.25 235.0	1.8125 46.038
99000 440000	180000 800000	0.33 1.80	M236800 Series													
			M236845	6.8750 174.625	2.1250 53.975	0.14 3.5	-0.26 -6.6	7.60 193.0	7.44 189.0	M236810	10.2500 260.350	1.6250 41.275	0.13 3.3	9.80 249.0	9.49 241.0	2.1250 53.975
			M236848	7.0000 177.800	2.1250 53.975	0.31 8.0	-0.26 -6.6	8.03 204.0	7.52 191.0							
			M236849	7.0000 177.800	2.1250 53.975	0.14 3.5	-0.26 -6.6	7.68 195.0	7.52 191.0							
150000 665000	236000 1050000	0.32 1.88	HM237500 Series													
			HM237523	6.3120 160.325	2.5000 63.500	0.28 7.0	-0.46 -11.7	7.56 192.0	7.13 181.0	HM237510	11.3750 288.925	1.8750 47.625	0.13 3.3	10.68 271.0	10.47 266.0	2.5000 63.500
			HM237535	6.5000 165.100	2.5000 63.500	0.28 7.0	-0.46 -11.7	7.68 195.0	7.24 184.0	▲ HM237510B	11.3750 288.925	1.8750 47.625	0.13 3.3	10.98 279.0	— —	2.5000 63.500
			HM237542	6.8750 174.625	2.5000 63.500	0.28 7.0	-0.46 -11.7	7.95 202.0	7.52 191.0	HM237513	11.4163 289.974	1.8898 48.000	0.12 3.0	10.69 272.0	10.51 267.0	2.5000 63.500
			HM237545	7.0000 177.800	2.5000 63.500	0.28 7.0	-0.46 -11.7	8.07 205.0	7.64 194.0							

* The maximum fillet on the shaft or in the housing that the bearing corner will clear.

† Positive value indicates the effective load center is outside the backface of the cone.

▲ For additional "B" cup dimensions, see pages 173 to 174.

■ For parts with a "J" prefix, use metric tolerances given on page 199 and fitting practice given on page 201.

★ Designate bearings with hollow rollers and pinned-type retainers.

◆ Bearing is equipped with seals (and in some instances side rings).

Basic Load Ratings		Axial Load Factor e Y_2	Cone Number	B	W_i	R	a	U	V	Cup Number	D	W_o	r	X	Z	W
Dynamic C_r	Static C_{or}			Bore Diameter	Cone Width	Maximum Shaft Fillet Radius †	Effective Load Center†	Minimum Shaft Shoulder Diameter	Minimum Shaft Shoulder Diameter		Outside Diameter	Cup Width	Maximum Housing Fillet Radius †	Maximum Housing Shoulder Diameter	Maximum Housing Shoulder Diameter	Bearing Width
lbs/N			Inch/mm							Inch/mm						
103000 460000	197000 875000	0.33 1.80	M238800 Series													
			M238840	7.0000 177.800	2.1875 55.562	0.14 3.5	-0.24 -6.1	7.80 198.0	7.64 194.0	M238810	10.6250 269.875	1.6875 42.862	0.13 3.3	10.08 256.0	9.84 250.0	2.1875 55.562
			M238849	7.3750 187.325	2.1875 55.562	0.14 3.5	-0.24 -6.1	8.07 205.0	7.91 201.0							
81500 365000	157000 695000	0.32 1.88	LM241100 Series													
			LM241149	8.0000 203.200	1.6875 42.862	0.14 3.5	0.07 1.8	8.62 219.0	8.43 214.0	LM241110	10.8750 276.225	1.3438 34.133	0.13 3.3	10.51 267.0	10.24 260.0	1.6875 42.862
118000 525000	227000 1010000	0.33 1.80	M241500 Series													
			M241543	7.8750 200.025	2.2813 57.945	0.14 3.5	-0.19 -4.8	8.62 219.0	8.46 215.0	M241510	11.5000 292.100	1.8125 46.038	0.13 3.3	10.98 279.0	10.71 272.0	2.2813 57.945
			M241547	8.0000 203.200	2.2813 57.945	0.14 3.5	-0.19 -4.8	8.70 221.0	8.54 217.0							
			M241549	8.0625 204.788	2.2813 57.945	0.14 3.5	-0.19 -4.8	8.78 223.0	8.62 219.0							
251000 1120000	580000 2590000	0.40 1.48	244000 Series													
			EE244180	18.0000 457.200	2.8750 73.025	0.38 9.7	+1.07 +27.1	19.65 499.0	18.35 466.0	244235	23.5000 596.900	2.1250 53.975	0.13 3.3	22.87 581.0	23.27 591.0	3.0000 76.200
135000 600000	264000 1170000	0.33 1.80	M244200 Series													
			M244249	8.6875 220.662	2.4375 61.912	0.25 6.4	-0.18 -4.6	9.65 245.0	9.25 235.0	M244210	12.3750 314.325	1.9375 49.212	0.13 3.3	11.81 300.0	11.54 293.0	2.4375 61.912
29200 130000	72000 320000	0.33 1.80	LL244500 Series													
			LL244549	9.1250 231.775	0.8465 21.500	0.08 2.0	0.62 15.7	9.49 241.0	9.33 237.0	LL244510	10.5625 268.288	0.7283 18.500	0.08 2.0	10.35 263.0	10.28 261.0	0.8858 22.500
160000 710000	315000 1410000	0.33 1.80	M246900 Series													
			M246942	9.1250 231.775	2.5625 65.088	0.25 6.4	-0.19 -4.8	10.16 258.0	9.80 249.0	M246910	13.2500 336.550	2.0000 50.800	0.13 3.3	12.68 322.0	12.32 313.0	2.5625 65.088
			M246949	9.3437 237.330	2.5625 65.088	0.25 6.4	-0.19 -4.8	10.31 262.0	9.96 253.0							
320000 1430000	600000 2660000	0.33 1.80	H247500 Series													
			H247535	7.8750 200.025	4.4375 112.712	0.25 6.4	-1.10 -27.9	9.49 241.0	9.09 231.0	H247510	15.1250 384.175	3.5625 90.488	0.25 6.4	14.26 362.0	13.62 346.0	4.4375 112.712
			H247549	9.2500 234.950	4.4375 112.712	0.25 6.4	-1.10 -27.9	10.59 269.0	10.20 259.0							
105000 465000	182000 810000	0.33 1.80	LM249700 Series													
			LM249748	10.0000 254.000	1.6875 42.862	0.14 3.5	-2.31 -58.8	10.67 271.0	10.63 270.0	LM244710	13.6875 347.662	1.2500 31.750	0.13 3.3	13.46 342.0	13.07 332.0	1.7500 44.450

- * The maximum fillet on the shaft or in the housing that the bearing corner will clear.
- † Positive value indicates the effective load center is outside the backface of the cone.
- ▲ For additional "B" cup dimensions, see pages 173 to 174.
- For parts with a "J" prefix, use metric tolerances given on page 199 and fitting practice given on page 201.
- ★ Designate bearings with hollow rollers and pinned-type retainers.
- ◆ Bearing is equipped with seals (and in some instances side rings).

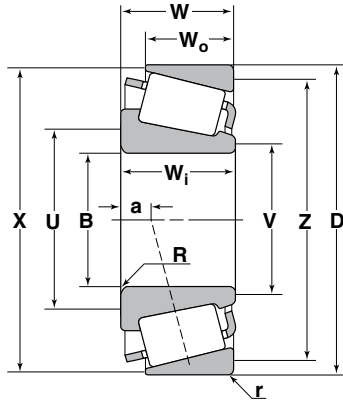

TS Type

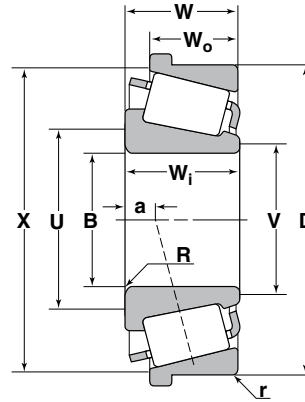

TSF Type

Basic Load Ratings		Axial Load Factor e Y_2	Cone Number	B	W_i	R	a	U	V	Cup Number	D	W_o	r	X	Z	W
Dynamic C_r	Static C_{or}			Bore Diameter	Cone Width	Maximum Shaft Fillet Radius †	Effective Load Center†	Minimum Shaft Shoulder Diameter	Minimum Shaft Shoulder Diameter		Outside Diameter	Cup Width	Maximum Housing Fillet Radius †	Maximum Housing Shoulder Diameter	Maximum Housing Shoulder Diameter	Bearing Width
lbs/N				Inch/mm						Inch/mm						
182000 810000	370000 1640000	0.33 1.80	M249700 Series													
			M249732	9.0000 228.600	2.8125 71.438	0.14 3.5	-0.27 -6.9	10.08 256.0	9.88 251.0	M249710	14.1250 358.775	2.1250 53.975	0.13 3.3	13.50 343.0	13.19 335.0	2.8125 71.438
			M249749	10.0000 254.000	2.8125 71.438	0.14 3.5	-0.27 -6.9	10.79 274.0	10.63 270.0	▲ M249710B	14.1250 358.775	2.1250 53.975	0.13 3.3	13.50 343.0	— —	2.8125 71.438
247000 1100000	375000 1670000	0.33 1.80	HM252300 Series													
			HM252348	10.2500 260.350	3.1406 79.771	0.27 6.8	-0.37 -9.4	11.50 292.0	11.22 285.0	HM252310	16.6250 422.275	2.6250 66.675	0.13 3.3	15.75 400.0	15.43 392.0	3.3906 86.121
195000 865000	390000 1740000	0.33 1.80	M252300 Series													
			M252330	9.2500 234.950	2.9375 74.612	0.25 6.4	-0.26 -6.6	10.67 271.0	10.28 261.0	M252310	15.0000 381.000	2.2500 57.150	0.13 3.3	14.32 364.0	14.02 356.0	2.9375 74.612
			M252337	9.7500 247.650	2.9375 74.612	0.25 6.4	-0.26 -6.6	11.02 280.0	10.67 271.0							
			M252349	10.6250 269.875	2.9375 74.612	0.25 6.4	-0.26 -6.6	11.65 296.0	11.30 287.0							
230000 1020000	470000 2090000	0.34 1.78	HM256800 Series													
			HM256849	11.8125 300.038	3.2500 82.550	0.25 6.4	-0.22 -5.6	12.91 328.0	12.56 319.0	HM256810	16.6250 422.275	2.5000 63.500	0.13 3.3	15.88 403.0	15.51 394.0	3.2500 82.550

* The maximum fillet on the shaft or in the housing that the bearing corner will clear.
 † Positive value indicates the effective load center is outside the backface of the cone.
 ▲ For additional "B" cup dimensions, see pages 173 to 174.
 ■ For parts with a "J" prefix, use metric tolerances given on page 199 and fitting practice given on page 201.
 ★ Designate bearings with hollow rollers and pinned-type retainers.
 ◆ Bearing is equipped with seals (and in some instances side rings).

Basic Load Ratings		Axial Load Factor e Y_2	Cone Number	B	W_j	R	a	U	V	Cup Number	D	W_o	r	X	Z	W
Dynamic C_r	Static C_{or}			Bore Diameter	Cone Width	Maximum Shaft Fillet Radius*	Effective Load Center†	Minimum Shaft Shoulder Diameter	Minimum Shaft Shoulder Diameter		Outside Diameter	Cup Width	Maximum Housing Fillet Radius*	Maximum Housing Shoulder Diameter	Maximum Housing Shoulder Diameter	Bearing Width
lbs/N			Inch/mm							Inch/mm						
256000 1140000	525000 2330000	0.33 1.79	HM259000 Series													
			HM259048	12.5000 317.500	3.3750 85.725	0.14 3.5	-0.19 -4.8	13.43 341.0	13.27 337.0	HM259010	17.6250 447.675	2.6875 68.262	0.13 3.3	16.84 428.0	16.46 418.0	3.3750 85.725
310000 1370000	650000 2890000	0.33 1.79	HM261000 Series													
			HM261049	13.1250 333.375	3.5625 90.488	0.25 6.4	-0.24 -6.1	14.29 363.0	14.06 357.0	HM261010	18.5000 469.900	2.8125 71.438	0.13 3.3	17.69 449.0	17.28 439.0	3.5625 90.488
310000 1390000	655000 2920000	0.33 1.79	HM262700 Series													
			HM262748	13.6250 346.075	3.7500 95.250	0.25 6.4	-0.25 -6.4	14.72 374.0	13.98 355.0	HM262710	19.2500 488.950	2.9375 74.612	0.13 3.3	18.90 480.0	18.62 473.0	3.7500 95.250
55000 246000	143000 635000	0.33 1.80	LL264600 Series													
			LL264648	14.7500 374.650	1.1250 28.575	0.14 3.5	1.10 27.9	15.31 389.0	15.12 384.0	LL264610	17.0000 431.800	0.8125 20.638	0.13 3.3	16.69 424.0	16.42 417.0	1.1250 28.575
385000 1720000	825000 3700000	0.33 1.80	HM266400 Series													
			HM266446	15.0000 381.000	4.1250 104.775	0.25 6.4	-0.28 -7.1	16.10 409.0	15.35 390.0	HM266410	21.5000 546.100	3.2500 82.550	0.25 6.4	21.30 541.0	20.39 518.0	4.1250 104.775
			HM266448	15.1250 384.175	4.1250 104.775	0.25 6.4	-0.28 -7.1	16.26 413.0	15.47 393.0	HM266413	21.6515 549.948	3.2500 82.550	0.25 6.4	21.42 544.0	20.55 522.0	4.1250 104.775
505000 2240000	930000 4150000	0.33 1.80	HM267100 Series													
			HM267146	15.0000 381.000	4.1250 104.775	0.25 6.4	-0.27 -6.9	16.10 409.0	15.35 390.0	HM267110	19.2500 488.950	2.9375 74.612	0.13 3.3	18.90 480.0	18.62 473.0	4.2500 107.950
			HM267148	15.1250 384.175	4.1250 104.775	0.25 6.4	-0.27 -6.9	16.26 413.0	15.47 393.0							
465000 2070000	1020000 4550000	0.33 1.80	M268700 Series													
			M268730	15.0000 381.000	4.5000 114.300	0.25 6.4	-0.37 -9.4	16.10 409.0	15.31 389.0	M268710	23.2500 590.550	3.5000 88.900	0.25 6.4	23.11 587.0	22.13 562.0	4.5000 114.300
			M268749	16.3750 415.925	4.5000 114.300	0.25 6.4	-0.37 -9.4	17.48 444.0	16.69 424.0							
335000 1490000	820000 3650000	0.33 1.80	LM272200 Series													
			LM272235	18.0000 457.200	3.3750 85.725	0.25 6.4	+0.49 +12.4	19.13 486.0	18.35 466.0	LM272210	24.2500 615.950	2.6250 66.675	0.25 6.4	24.02 610.0	23.15 588.0	3.3750 85.725
			LM272249	19.0000 482.600	3.3750 85.725	0.25 6.4	+0.49 +12.4	20.12 511.0	19.33 491.0							
38500 171000	48500 216000	0.35 1.73	H307700 Series													
			■ JH307749	2.1654 55.000	1.5354 39.000	0.12 3.0	-0.46 -11.7	2.80 71.0	2.52 64.0	■ JH307710	4.3307 110.000	1.2598 32.000	0.10 2.5	4.09 104.0	3.82 97.0	1.5354 39.000
60500 269000	86000 380000	0.34 1.76	HM318400 Series													
			■ JHM318448	3.5433 90.000	1.7323 44.000	0.12 3.0	-0.39 -9.9	4.17 106.0	3.94 100.0	■ JHM318410	6.1024 155.000	1.3976 35.500	0.10 2.5	5.83 148.0	5.51 140.0	1.7323 44.000

* The maximum fillet on the shaft or in the housing that the bearing corner will clear.
† Positive value indicates the effective load center is outside the backface of the cone.
▲ For additional "B" cup dimensions, see pages 173 to 174.
■ For parts with a "J" prefix, use metric tolerances given on page 199 and fitting practice given on page 201.
★ Designate bearings with hollow rollers and pinned-type retainers.
◆ Bearing is equipped with seals (and in some instances side rings).

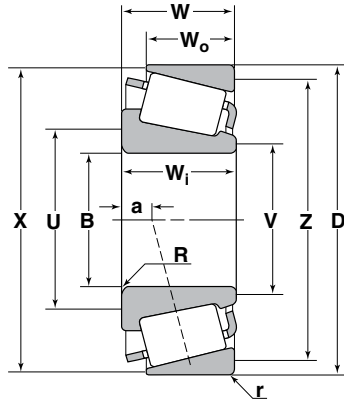

TS Type

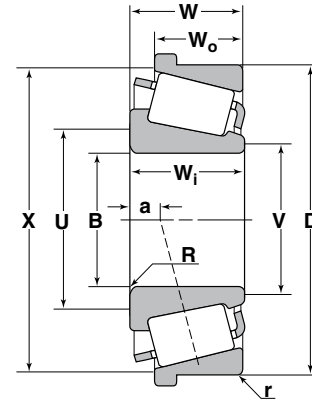

TSF Type

Basic Load Ratings		Axial Load Factor e Y_2	Cone Number	B	W_i	R	a	U	V	Cup Number	D	W_o	r	X	Z	W
Dynamic C_r	Static C_{or}			Bore Diameter	Cone Width	Maximum Shaft Fillet Radius *	Effective Load Center †	Minimum Shaft Shoulder Diameter	Minimum Shaft Shoulder Diameter		Outside Diameter	Cup Width	Maximum Housing Fillet Radius *	Maximum Housing Shoulder Diameter	Maximum Housing Shoulder Diameter	Bearing Width
lbs/N				Inch/mm						Inch/mm						
192000 855000	345000 1530000	0.35 1.73	H337800 Series													
			H337837	6.3120 160.325	3.0709 78.000	0.31 7.9	-0.60 -15.3	7.68 195.0	6.61 168.0	H337810	11.3750 288.925	2.5591 65.000	0.13 3.3	11.14 283.0	10.75 273.0	3.0709 78.000
156000 695000	310000 1390000	0.34 1.75	M348400 Series													
			M348448WS	9.7500 247.650	2.5000 63.500	0.25 6.4	-0.05 -1.3	10.75 273.0	10.35 263.0	M348410	13.6250 346.075	2.0000 50.800	0.25 6.4	13.07 332.0	12.64 321.0	2.5000 63.500
			M348449	9.7500 247.650	2.5000 63.500	0.25 6.4	-0.05 -1.3	10.75 273.0	10.35 263.0							
134000 595000	277000 1230000	0.35 1.73	M349500 Series													
			M349549	10.1250 257.175	2.2500 57.150	0.25 6.4	0.10 2.5	11.06 281.0	10.59 269.0	M349510	13.5000 342.900	1.7500 44.450	0.13 3.3	13.11 333.0	12.68 322.0	2.2500 57.150
			M349549A	10.1250 257.175	2.2500 57.150	0.42 10.7	0.10 2.5	11.38 289.0	10.59 269.0							
250000 1110000	320000 1430000	0.76 0.79	350000 Series													
			EE350701	7.0000 177.800	3.7500 92.250	0.25 6.4	0.51 13.0	9.06 230.0	8.70 221.0	351687	16.8758 428.625	2.4375 61.912	0.25 6.4	15.08 383.0	14.37 365.0	4.1875 106.362
			EE350750	7.5000 190.500	3.7500 92.250	0.25 6.4	0.51 13.0	9.45 240.0	9.32 237.0							
117000 520000	256000 1140000	0.36 1.67	L357000 Series													
			L357049	12.0000 304.800	2.0000 50.800	0.25 6.4	0.50 12.7	12.95 329.0	12.56 319.0	L357010	15.5000 393.700	1.5000 38.100	0.13 3.3	14.96 380.0	14.72 374.0	2.0000 50.800
										▲ L357019B	15.9429 404.950	1.5000 38.100	0.13 3.3	14.96 380.0	—	2.0000 50.800

* The maximum fillet on the shaft or in the housing that the bearing corner will clear.
 † Positive value indicates the effective load center is outside the backface of the cone.
 ▲ For additional "B" cup dimensions, see pages 173 to 174.
 ■ For parts with a "J" prefix, use metric tolerances given on page 199 and fitting practice given on page 201.
 ★ Designate bearings with hollow rollers and pinned-type retainers.
 ◆ Bearing is equipped with seals (and in some instances side rings).

Basic Load Ratings		Axial Load Factor e/Y_2	Cone Number	B	W_i	R	a	U	V	Cup Number	D	W_o	r	X	Z	W
Dynamic C_r	Static C_{or}			Bore Diameter	Cone Width	Maximum Shaft Fillet Radius †	Effective Load Center†	Minimum Shaft Shoulder Diameter	Minimum Shaft Shoulder Diameter		Outside Diameter	Cup Width	Maximum Housing Fillet Radius †	Maximum Housing Shoulder Diameter	Maximum Housing Shoulder Diameter	Bearing Width
lbs/N				Inch/mm						Inch/mm						
50000 222000	64500 287000	0.36 1.67	H414200 Series													
			H414235	2.5000 63.500	1.6250 41.275	0.14 3.5	-0.43 -10.9	3.23 82.0	3.07 78.0	H414210	5.3750 136.525	1.2500 31.750	0.13 3.3	5.08 129.0	4.76 121.0	1.6250 41.275
			H414242	2.6250 66.675	1.6250 41.275	0.14 3.5	-0.43 -10.9	3.35 85.0	3.19 81.0	▲ H414210B	5.3750 136.525	1.2500 31.750	0.13 3.3	5.12 130.0	—	1.6250 41.275
			H414245	2.6875 68.262	1.6250 41.275	0.14 3.5	-0.43 -10.9	3.39 86.0	3.23 82.0							
			H414249	2.8125 71.438	1.6250 41.275	0.14 3.5	-0.43 -10.9	3.50 89.0	3.27 83.0							
64000 285000	91000 405000	0.36 1.66	H415600 Series													
			■ JH415647	2.9528 75.000	2.0079 51.000	0.12 3.0	-0.56 -14.2	3.70 94.0	3.50 89.0	■ JH415610	5.7087 145.000	1.6235 42.000	0.10 2.5	5.47 139.0	5.08 129.0	2.0079 51.000
21700 96500	41500 184000	0.37 1.64	LL428300 Series													
			LL428349	5.5000 139.700	0.8125 20.638	0.06 1.5	0.31 7.9	5.83 148.0	5.75 146.0	LL428310	7.1250 180.975	0.6563 16.670	0.06 1.5	6.89 175.0	6.77 172.0	0.8438 21.433
28500 127000	56000 249000	0.37 1.61	L432300 Series													
			L432348	6.2500 158.750	0.9375 23.812	0.19 4.8	0.37 9.4	6.85 174.0	6.54 166.0	L432310	8.0938 205.583	0.7188 18.258	0.06 1.5	7.83 199.0	7.68 195.0	0.9375 23.812
			L432349	6.2500 158.750	0.9375 23.812	0.06 1.5	0.37 9.4	6.61 168.0	6.54 166.0							
217000 965000	390000 1740000	0.60 0.99	435000 Series													
			EE435102	10.2500 260.350	3.3125 84.138	0.25 6.4	0.78 19.8	11.61 295.0	11.22 285.0	435165	16.5000 419.100	2.4375 61.912	0.13 3.3	15.56 395.0	14.80 376.0	3.3750 85.725
192000 855000	284000 1260000	0.33 1.84	450000 Series													
			EE450601	6.0000 152.400	3.6875 93.662	0.38 9.7	-1.11 -28.2	7.44 189.0	6.97 177.0	451212	12.1250 307.975	2.4375 61.912	0.27 6.8	10.82 275.0	10.59 269.0	3.5000 88.900
138000 615000	293000 1300000	0.36 1.67	LM451300 Series													
			LM451345	10.3750 263.525	2.2500 57.150	0.14 3.5	0.20 5.1	11.14 283.0	10.98 279.0	LM451310	14.0000 355.600	1.7500 44.450	0.13 3.3	13.50 343.0	13.19 335.0	2.2500 57.150
			LM451349	10.5000 266.700	2.2500 57.150	0.14 3.5	0.20 5.1	11.22 285.0	11.06 281.0	▲ LM451310B	14.0000 355.600	1.7500 44.450	0.13 3.3	13.54 344.0	—	2.2500 57.150
			LM451349A	10.5000 266.700	2.2500 57.150	0.41 10.5	0.20 5.1	11.77 299.0	11.06 281.0							
			LM451349AX	10.5000 266.700	2.2500 57.150	0.38 9.7	0.20 5.1	11.69 297.0	11.06 281.0							
44500 198000	55500 248000	0.40 1.49	HH506300 Series													
			HH506348	1.9375 49.212	1.7500 44.450	0.14 3.5	-0.53 -13.5	2.80 71.0	2.40 61.0	HH506310	4.5000 114.300	1.4200 36.068	0.13 3.3	4.21 107.0	3.82 97.0	1.7500 44.450
			HH506349	1.9680 49.987	1.7500 44.450	0.14 3.5	-0.53 -13.5	2.83 72.0	2.40 61.0							

* The maximum fillet on the shaft or in the housing that the bearing corner will clear.
† Positive value indicates the effective load center is outside the backface of the cone.
▲ For additional "B" cup dimensions, see pages 173 to 174.
■ For parts with a "J" prefix, use metric tolerances given on page 199 and fitting practice given on page 201.
★ Designate bearings with hollow rollers and pinned-type retainers.
◆ Bearing is equipped with seals (and in some instances side rings).

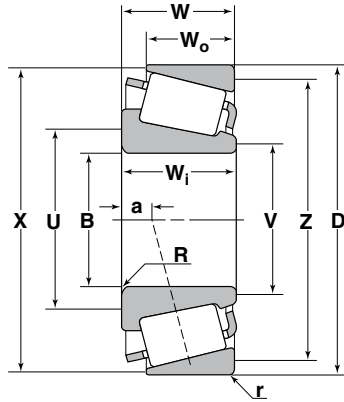

TS Type

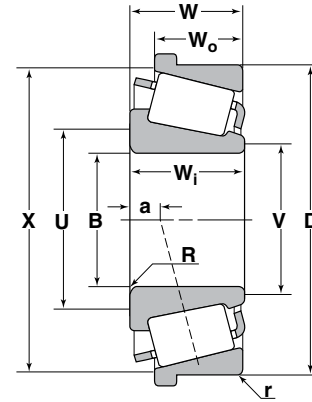

TSF Type

Basic Load Ratings		Axial Load Factor e Y_2	Cone Number	B	W_i	R	a	U	V	Cup Number	D	W_o	r	X	Z	W
Dynamic C_r	Static C_{or}			Bore Diameter	Cone Width	Maximum Shaft Fillet Radius*	Effective Load Center†	Minimum Shaft Shoulder Diameter	Minimum Shaft Shoulder Diameter		Outside Diameter	Cup Width	Maximum Housing Fillet Radius*	Maximum Housing Shoulder Diameter	Maximum Housing Shoulder Diameter	Bearing Width
lbs/N				Inch/mm						Inch/mm						
25300 113000	36500 163000	0.40 1.49	M511900 Series													
			■ JM511945	2.5591 65.000	1.1811 30.000	0.12 3.0	-0.13 -3.3	3.07 78.0	2.83 72.0	■ JM511910	4.3307 110.000	0.8858 22.500	0.10 2.5	4.13 105.0	3.90 99.0	1.1024 28.000
			■ JM511946	2.5591 65.000	1.1024 28.000	0.12 3.0	-0.13 -3.3	3.07 78.0	2.83 72.0							
37000 164000	55000 245000	0.39 1.54	M515600 Series													
			■ JM515649	3.1496 80.000	1.3386 34.000	0.12 3.0	-0.20 -5.1	3.70 94.0	3.46 88.0	■ JM515610	5.1181 130.000	1.1220 28.500	0.10 2.5	4.92 125.0	4.61 117.0	1.3780 35.000
40500 180000	69000 305000	0.40 1.49	HM516400 Series													
			HM516442	3.0000 76.200	1.5625 39.688	0.14 3.5	-0.29 -7.4	3.66 93.0	3.43 87.0	HM516410	5.2500 133.350	1.2813 32.545	0.13 3.3	5.04 128.0	4.65 118.0	1.5625 39.688
			HM516448	3.2500 82.550	1.5625 39.688	0.27 6.8	-0.29 -7.4	4.13 105.0	3.62 92.0	▲ HM516414B	5.3750 136.525	1.2813 32.545	0.06 1.5	5.04 128.0	—	1.5625 39.688
			HM516449	3.2500 82.550	1.5625 39.688	0.14 3.5	-0.29 -7.4	3.90 99.0	3.62 92.0							
			HM516449A	3.2500 82.550	1.5625 39.688	Spec. Spec.	-0.29 -7.4	4.61 117.0	3.62 92.0							
55000 245000	78500 350000	0.40 1.49	HM518400 Series													
			HM518445	3.5000 88.900	1.5625 39.688	0.25 6.4	-0.25 -6.4	4.21 107.0	3.82 97.0	HM518410	6.0000 152.400	1.1875 30.162	0.13 3.3	5.79 147.0	5.43 138.0	1.5625 39.688
19300 85500	37000 164000	0.39 1.53	L521900 Series													
			L521945	4.0000 101.600	0.8438 21.433	0.06 1.5	0.19 4.8	4.41 112.0	4.29 109.0	L521910	5.7500 146.050	0.6563 16.670	0.06 1.5	5.55 141.0	5.35 136.0	0.8438 21.433
			L521949	4.2500 107.950	0.8438 21.433	0.06 1.5	0.19 4.8	4.57 116.0	4.49 114.0	L521914	6.0000 152.400	0.6563 16.670	0.06 1.5	5.67 144.0	5.47 139.0	0.8438 21.433

* The maximum fillet on the shaft or in the housing that the bearing corner will clear.
 † Positive value indicates the effective load center is outside the backface of the cone.
 ▲ For additional "B" cup dimensions, see pages 173 to 174.
 ■ For parts with a "J" prefix, use metric tolerances given on page 199 and fitting practice given on page 201.
 ★ Designate bearings with hollow rollers and pinned-type retainers.
 ◆ Bearing is equipped with seals (and in some instances side rings).

Basic Load Ratings		Axial Load Factor $e Y_2$	Cone Number	B	W_1	R	a	U	V	Cup Number	D	W_0	r	X	Z	W
Dynamic C_r	Static C_{or}			Bore Diameter	Cone Width	Maximum Shaft Fillet Radius †	Effective Load Center †	Minimum Shaft Shoulder Diameter	Minimum Shaft Shoulder Diameter		Outside Diameter	Cup Width	Maximum Housing Fillet Radius †	Maximum Housing Shoulder Diameter	Maximum Housing Shoulder Diameter	Bearing Width
lbs/N				Inch/mm						Inch/mm						
38000 170000	73500 325000	0.40 1.49	LM522500 Series													
			LM522546	4.2500 107.950	1.3750 34.925	0.14 3.5	-0.06 -1.5	4.80 122.0	4.57 116.0	LM522510	6.2987 159.987	1.0625 26.988	0.13 3.3	6.06 154.0	5.75 146.0	1.3750 34.925
			LM522548	4.3302 109.987	1.3750 34.925	0.31 8.0	-0.06 -1.5	5.24 133.0	4.65 118.0							
			LM522549	4.3302 109.987	1.3750 34.925	0.14 3.5	-0.06 -1.5	4.88 124.0	4.65 118.0							
67500 300000	106000 475000	0.41 1.48	HM522600 Series													
			■ JHM522649	4.3307 110.000	1.8110 46.000	0.12 3.0	-0.23 -5.8	5.00 127.0	4.79 122.0	■ JHM522610	7.0866 180.000	1.4961 38.000	0.10 2.5	6.77 172.0	6.38 162.0	1.8504 47.000
			■ JHM522649A	4.3307 110.000	1.8110 46.000	.28 7.0	-0.23 -5.8	5.63 143.0	4.79 122.0							
310000 1370000	555000 2470000	0.39 1.54	526000 Series													
			EE526130	13.0000 330.200	3.1562 80.167	0.25 6.4	0.19 4.8	14.17 360.0	13.82 351.0	526190	19.0000 482.600	2.3750 60.325	0.13 3.3	17.87 454.0	17.68 449.0	3.3750 85.725
										▲ 526190B	19.0000 482.600	2.3750 60.325	0.13 3.3	18.27 464.0	—	3.3750 85.725
77000 345000	141000 625000	0.39 1.53	M533300 Series													
			M533349S	6.5000 165.100	1.7323 44.000	0.14 3.5	0.06 1.5	6.97 177.0	6.81 173.0	M533310	9.1339 232.000	1.4173 36.000	0.14 3.5	8.94 227.0	8.54 217.0	1.7717 45.000
62000 277000	114000 570000	0.38 1.57	HM534100 Series													
			■ JHM534149	6.6929 170.000	1.4961 38.000	0.12 3.0	0.18 4.6	7.24 184.0	7.01 178.0	■ JHM534110	9.0551 230.000	1.2205 31.000	0.10 2.5	8.82 244.0	8.54 217.0	1.5354 39.000
120000 530000	228000 1010000	0.40 1.49	HM535300 Series													
			HM535349	6.7500 171.450	2.6250 66.675	0.14 3.5	0.34 8.6	7.56 192.0	7.40 188.0	HM535310	10.2500 260.350	2.0625 52.388	0.13 3.3	9.84 250.0	9.29 236.0	2.6250 66.675
45500 202000	89000 395000	0.39 1.56	543000 Series													
			543085	8.5000 215.900	1.2500 31.750	0.14 3.5	0.51 13.0	9.13 232.0	8.90 226.0	543114	11.4177 290.010	0.8750 22.225	0.13 3.3	10.87 276.0	10.71 272.0	1.2500 31.750
			543086	8.6602 219.969	1.2500 31.750	0.14 3.5	0.51 13.0	9.25 235.0	9.02 229.0							
46500 207000	93000 415000	0.40 1.49	544000 Series													
			544090	9.0000 228.600	1.2500 31.750	0.14 3.5	0.62 15.7	9.61 244.0	9.45 240.0	544116	11.6250 295.275	0.9375 23.812	0.13 3.3	11.30 287.0	10.98 279.0	1.3125 33.338
			544091	9.1250 231.775	1.2500 31.750	0.14 3.5	0.62 15.7	9.72 247.0	9.57 243.0	544118	11.8125 300.038	0.9375 23.812	0.13 3.3	11.30 287.0	11.10 282.0	1.3125 33.338
103000 460000	202000 900000	0.40 1.51	LM545800 Series													
			LM545845	9.1250 231.775	1.9375 49.212	0.25 6.4	0.33 8.4	10.24 260.0	9.49 241.0	LM545810	12.3750 314.325	1.4375 36.512	0.13 3.3	12.05 306.0	11.65 296.0	1.9375 49.212
			LM545848	9.2460 234.848	2.1250 53.973	0.14 3.5	0.33 8.4	9.92 252.0	9.61 244.0							
			LM545849	9.2500 234.950	1.9375 49.212	0.14 3.5	0.33 8.4	9.92 252.0	9.69 246.0							
			LM545849A	9.2500 234.950	1.9375 49.212	0.25 6.4	0.33 8.4	10.16 258.0	9.69 246.0							

* The maximum fillet on the shaft or in the housing that the bearing corner will clear.

† Positive value indicates the effective load center is outside the backface of the cone.

▲ For additional "B" cup dimensions, see pages 173 to 174.

■ For parts with a "J" prefix, use metric tolerances given on page 199 and fitting practice given on page 201.

★ Designate bearings with hollow rollers and pinned-type retainers.

◆ Bearing is equipped with seals (and in some instances side rings).

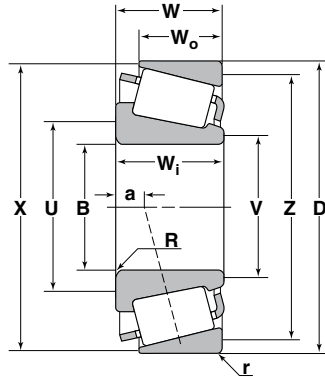

TS Type

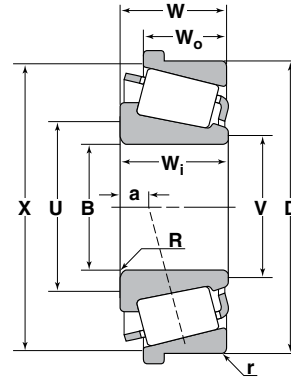

TSF Type

Basic Load Ratings		Axial Load Factor e Y_2	Cone Number	B	W_i	R	a	U	V	Cup Number	D	W_o	r	X	Z	W
Dynamic C_r	Static C_{or}			Bore Diameter	Cone Width	Maximum Shaft Fillet Radius †	Effective Load Center †	Minimum Shaft Shoulder Diameter	Minimum Shaft Shoulder Diameter		Outside Diameter	Cup Width	Maximum Housing Fillet Radius *	Maximum Housing Shoulder Diameter	Maximum Housing Shoulder Diameter	Bearing Width
lbs/N				Inch/mm						Inch/mm						
105000 470000	228000 1020000	0.40 1.49	L555200 Series													
			L555233	11.0000 279.400	1.8750 47.625	0.14 3.5	0.69 17.5	11.81 300.0	11.65 296.0	L555210	14.7500 374.650	1.3750 34.925	0.13 3.3	14.25 362.0	13.98 355.0	1.8750 47.625
			L555249	11.5000 292.100	1.8750 47.625	0.14 3.5	0.69 17.5	12.17 309.0	12.01 305.0							
274000 1220000	575000 2550000	0.39 1.56	LM565900 Series													
			LM565943	14.7500 374.650	3.3125 84.138	0.25 6.4	0.35 8.9	15.87 403.0	15.08 383.0	LM565910	20.5625 522.287	2.4375 61.912	0.13 3.3	20.35 517.0	19.92 506.0	3.3750 85.724
			LM565946	14.8750 377.825	3.3125 84.138	0.25 6.4	0.35 8.9	15.98 406.0	15.24 387.0	LM565912	20.6250 523.875	2.4375 61.912	0.13 3.3	20.39 518.0	20.00 508.0	3.3750 85.724
			LM565949	15.0000 381.000	3.3125 84.138	0.25 6.4	0.35 8.9	16.10 409.0	15.35 390.0							
12300 55000	15600 69500	0.43 1.41	LM603000 Series													
			LM603049	1.7812 45.242	0.7812 19.842	0.14 3.5	-0.09 -2.3	2.24 57.0	1.97 50.0	LM603011	3.0625 77.788	0.5937 15.080	0.03 0.8	2.91 74.0	2.80 71.0	0.7812 19.842
										LM603012	3.0625 77.788	0.6562 16.667	0.03 0.8	2.91 74.0	2.76 70.0	0.8437 21.430
										LM603014	3.1486 79.974	0.5937 15.080	0.03 0.8	2.95 75.0	2.80 71.0	0.7812 19.842
13100 58500	22100 98000	0.42 1.41	L610500 Series													
			L610549	2.5000 63.500	0.7500 19.050	0.06 1.5	0.02 0.5	2.80 71.0	2.72 69.0	L610510	3.7188 94.458	0.5938 15.083	0.06 1.5	3.58 91.0	3.39 86.0	0.7500 19.050
27500 122000	38000 169000	0.43 1.40	M612900 Series													
			■ JM612949	2.7559 70.000	1.1417 29.000	0.12 3.0	-0.10 -2.5	3.27 83.0	3.03 77.0	■ JM612910	4.5276 115.000	0.9055 23.000	0.10 2.5	4.33 110.0	4.06 103.0	1.1417 29.000
18700 83500	25200 112000	0.42 1.44	LM613400 Series													
			LM613449	2.7500 69.850	0.8660 21.996	0.06 1.5	0.00 0.0	3.07 78.0	2.99 76.0	LM613410	4.4375 112.712	0.6250 15.875	0.03 0.8	4.21 107.0	4.09 104.0	0.8750 22.225
										▲ LM613410B	4.4375 112.712	0.6250 15.875	0.03 0.8	4.33 110.0	—	0.8750 22.225

* The maximum fillet on the shaft or in the housing that the bearing corner will clear.

† Positive value indicates the effective load center is outside the backface of the cone.

▲ For additional "B" cup dimensions, see pages 173 to 174.

■ For parts with a "J" prefix, use metric tolerances given on page 199 and fitting practice given on page 201.

★ Designate bearings with hollow rollers and pinned-type retainers.

◆ Bearing is equipped with seals (and in some instances side rings).

Basic Load Ratings		Axial Load Factor $e Y_2$	Cone Number	B	W_f	R	a	U	V	Cup Number	D	W_o	r	X	Z	W
Dynamic C_r	Static C_{or}			Bore Diameter	Cone Width	Maximum Shaft Fillet Radius †	Effective Load Center †	Minimum Shaft Shoulder Diameter	Minimum Shaft Shoulder Diameter		Outside Diameter	Cup Width	Maximum Housing Fillet Radius †	Maximum Housing Shoulder Diameter	Maximum Housing Shoulder Diameter	Bearing Width
lbs/N			Inch/mm							Inch/mm						
47000 210000	77000 340000	0.43 1.39	HM617000 Series HM617049	3.3750 85.725	1.6875 42.862	0.19 4.8	-0.29 -7.4	4.17 106.0	3.75 95.0	HM617010	5.5960 142.138	1.3438 34.133	0.12 3.0	5.39 137.0	4.92 125.0	1.6875 42.862
19800 88000	39000 173000	0.41 1.45	L623100 Series L623149	4.5000 114.300	0.8438 21.433	0.06 1.5	0.25 6.4	4.84 123.0	4.72 120.0	L623110	6.0000 152.400	0.6563 16.670	0.06 1.5	5.79 147.0	5.63 143.0	0.8438 21.433
20500 91000	41500 185000	0.43 1.38	L624500 Series L624549	4.7500 120.650	0.8438 21.433	0.06 1.5	0.33 8.4	5.08 129.0	5.00 127.0	L624510 ▲L624510B	6.3125 160.338 6.3125 160.338	0.6563 16.670 0.6563 16.670	0.06 1.5 0.06 1.5	6.10 155.0 6.18 157.0	5.91 150.0 — —	0.8438 21.433 0.8438 21.433
71500 315000	117000 520000	0.43 1.41	HM624700 Series HM624749	4.7500 120.650	1.8125 46.038	0.14 3.5	-0.15 -3.8	5.43 138.0	5.20 132.0	HM624710	7.5000 190.500	1.3750 34.925	0.06 1.5	7.24 184.0	6.85 174.0	1.8125 46.038
34500 153000	70000 310000	0.42 1.44	L630300 Series L630349	6.0000 152.400	0.9449 24.000	0.08 2.0	0.40 10.2	6.38 162.0	6.22 158.0	L630310 L630310B	7.5625 192.088 7.5625 192.088	0.7480 19.000 0.7480 19.000	0.08 2.0 0.08 2.0	7.36 187.0 7.44 189.0	7.20 183.0 — —	0.9843 25.000 0.9843 25.000
36000 160000	74000 330000	0.42 1.44	LL639200 Series LL639249	7.7500 196.850	0.9062 23.017	0.06 1.5	0.68 17.3	8.07 205.0	7.91 201.0	LL639210	9.5000 241.300	0.6875 17.462	0.06 1.5	9.29 236.0	9.17 233.0	0.9375 23.812
350000 1550000	725000 3200000	0.31 1.95	640000 Series EE640191 EE640192	19.2390 488.671 19.2500 488.950	3.7188 94.458 3.7188 94.458	0.25 6.4 0.25 6.4	0.16 4.1 0.16 4.1	20.35 517.0 20.35 517.0	19.88 505.0 19.92 506.0	640260	26.0000 660.400 26.0000 660.400	2.7500 69.850 2.7500 69.850	0.25 6.4 0.25 6.4	25.79 655.0 25.79 655.0	24.88 632.0 24.88 632.0	3.6875 93.662 3.6875 93.662
149000 660000	350000 1550000	0.43 1.39	LM654600 Series LM654642 LM654649	11.0229 279.982 11.2500 285.750	2.5625 65.088 2.5625 65.088	0.14 3.5 0.14 3.5	0.45 11.4 0.45 11.4	11.89 302.0 12.05 306.0	11.73 298.0 11.89 302.0	LM654610 ▲LM654610B	14.9960 380.898 14.9960 380.898	1.9375 49.212 1.9375 49.212	0.13 3.3 0.13 3.3	14.49 368.0 14.49 368.0	14.02 356.0 — —	2.5625 65.088 2.5625 65.088
128000 570000	289000 1290000	0.42 1.42	L659600 Series L659649	13.0000 330.200	1.8750 47.625	0.50 12.7	1.03 26.2	15.16 385.0	13.31 338.0	L659610	16.3750 415.925	1.4375 36.512	0.13 3.3	16.14 410.0	15.75 400.0	1.8750 47.625
253000 1130000	575000 2570000	0.42 1.43	LM665900 Series LM665949 LM665949A	15.1875 385.762 15.1875 385.762	3.2500 82.550 3.2500 82.550	0.25 6.4 0.59 15.0	0.64 16.3 0.64 16.3	16.30 414.0 17.68 449.0	15.55 395.0 15.55 395.0	LM665910	20.2500 514.350	2.5000 63.500	0.13 3.3	20.04 509.0	19.61 498.0	3.2500 82.550
194000 86000	26600 118000	0.45 1.32	LM710900 Series ■JLM710949	2.5591 65.000	0.9055 23.000	0.12 3.0	-0.01 -0.3	3.03 77.0	2.80 71.0	■JLM710910	4.1339 105.000	0.7283 18.500	0.04 1.0	3.96 101.0	3.78 96.0	0.9449 24.000

* The maximum fillet on the shaft or in the housing that the bearing corner will clear.

† Positive value indicates the effective load center is outside the backface of the cone.

▲ For additional "B" cup dimensions, see pages 173 to 174.

■ For parts with a "J" prefix, use metric tolerances given on page 199 and fitting practice given on page 201.

★ Designate bearings with hollow rollers and pinned-type retainers.

◆ Bearing is equipped with seals (and in some instances side rings).

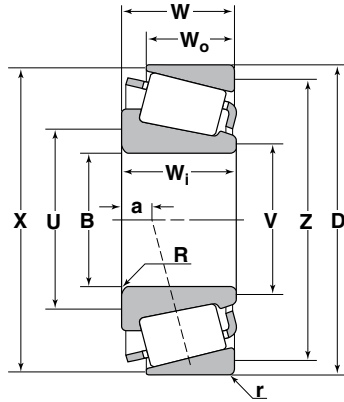

TS Type

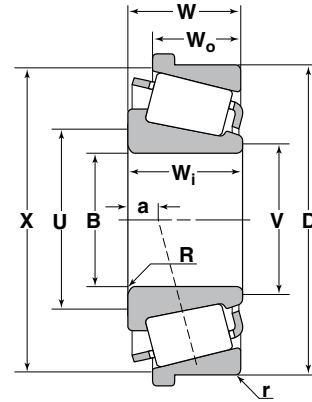

TSF Type

Basic Load Ratings		Axial Load Factor e Y_2	Cone Number	B	W_i	R	a	U	V	Cup Number	D	W_o	r	X	Z	W
Dynamic C_r	Static C_{or}			Bore Diameter	Cone Width	Maximum Shaft Fillet Radius \dagger	Effective Load Center \dagger	Minimum Shaft Shoulder Diameter	Minimum Shaft Shoulder Diameter		Outside Diameter	Cup Width	Maximum Housing Fillet Radius \star	Maximum Housing Shoulder Diameter	Maximum Housing Shoulder Diameter	Bearing Width
lbs/N				Inch/mm						Inch/mm						
22000 98000	32500 143000	0.46 1.31	LM714100 Series ■ JLM714149	2.9528 75.000	0.9843 25.000	0.12 3.0	0.02 0.5	3.43 87.0	3.19 81.0	■ JLM714110	4.5276 115.000	0.7480 19.000	0.10 2.5	4.33 110.0	4.09 104.0	0.9843 25.000
29400 131000	44000 196000	0.44 1.35	M714200 Series ■ JM714249 ■ JM714249A	2.9528 75.000	1.1614 29.500	0.12 3.0	-0.08 -2.0	3.54 90.0	3.27 83.0	■ JM714210 ■ JM714210A	4.7244 120.000	0.9843 25.000	0.10 2.5	4.53 115.0	4.21 107.0	1.2205 31.000
50000 221000	79000 350000	0.47 1.27	H715300 Series H715332 H715332S H715334 H715336 H715340 H715341 H715343 H715345 H715346 H715348	2.3750 60.325 2.3750 60.325 2.4375 61.912 2.5000 63.500 2.5625 65.088 2.6250 66.675 2.6875 68.262 2.8125 71.438 3.0000 76.200 3.0625 77.788	1.8125 46.038 1.8125 46.038 1.8125 46.038 1.8125 46.038 1.8125 46.038 1.8125 46.038 1.8125 46.038 1.8125 46.038 1.8125 46.038 1.8125 46.038	0.14 3.5 0.14 3.5 0.14 3.5 0.14 3.5 0.14 3.5 0.14 3.5 0.14 3.5 0.14 3.5 0.14 3.5 0.14 3.5	-0.34 -8.6 -0.34 -8.6 -0.34 -8.6 -0.34 -8.6 -0.34 -8.6 -0.34 -8.6 -0.34 -8.6 -0.34 -8.6 -0.34 -8.6 -0.34 -8.6	3.31 84.0 3.31 84.0 3.39 86.0 3.43 87.0 3.46 88.0 3.50 89.0 3.54 90.0 3.66 93.0 3.86 98.0 3.86 98.0	3.07 78.0 3.07 78.0 3.11 79.0 3.15 80.0 3.23 82.0 3.27 83.0 3.31 84.0 3.43 87.0 3.48 88.0 3.48 88.0	H715310 ▲ H715310B H715311	5.5000 139.700 5.5000 139.700 5.3750 136.525	1.4375 36.512 1.4375 36.512 1.4375 36.512	0.13 3.3 0.13 3.3 0.13 3.3	5.24 133.0 5.31 135.0 5.20 132.0	4.72 120.0 — — 4.65 118.0	1.8125 46.038 1.8125 46.038 1.8125 46.038

* The maximum fillet on the shaft or in the housing that the bearing corner will clear.
 † Positive value indicates the effective load center is outside the backface of the cone.
 ▲ For additional "B" cup dimensions, see pages 173 to 174.
 ■ For parts with a "J" prefix, use metric tolerances given on page 199 and fitting practice given on page 201.
 ★ Designate bearings with hollow rollers and pinned-type retainers.
 ◆ Bearing is equipped with seals (and in some instances side rings).

Basic Load Ratings		Axial Load Factor e Y_2	Cone Number	B	W_1	R	a	U	V	Cup Number	D	W_0	r	X	Z	W	
Dynamic C_r	Static C_{or}			Bore Diameter	Cone Width	Maximum Shaft Fillet Radius †	Effective Load Center†	Minimum Shaft Shoulder Diameter	Minimum Shaft Shoulder Diameter		Outside Diameter	Cup Width	Maximum Housing Fillet Radius *	Maximum Housing Shoulder Diameter	Maximum Housing Shoulder Diameter	Bearing Width	
lbs/N			Inch/mm							Inch/mm							
30500 135000	48000 214000	0.44 1.35	M716600 Series							JM716610							
			■ JM716648	3.3465 85.000	1.1417 29.000	0.24 6.0	-0.01 -0.3	4.09 104.0	3.62 92.0		5.1181 130.000	0.9449 24.000	0.10 2.5	4.92 125.0	4.61 117.0	1.1811 30.000	
			■ JM716649	3.3465 85.000	1.1417 29.000	0.12 3.0	-0.01 -0.3	3.86 98.0	3.62 92.0	▲ JM716610B	5.1181 130.000	0.9449 24.000	0.10 2.5	5.00 127.0	— —	1.1811 30.000	
41000 183000	61000 270000	0.44 1.35	M718100 Series							JM718110							
			■ JM718149	3.5433 90.000	1.3386 34.000	0.12 3.0	-0.08 -2.0	4.13 105.0	3.90 99.0		5.7087 145.000	1.0630 27.000	0.10 2.5	5.46 139.0	5.16 131.0	1.3780 35.000	
			■ JM718149A	3.5433 90.000	1.3386 34.000	0.24 6.0	-0.08 -2.0	4.37 111.0	3.90 99.0								
29600 132000	42500 189000	0.48 1.25	LM718900 Series							LM718910							
			LM718947	3.6210 91.973	1.1811 30.000	0.14 3.5	0.07 1.8	4.17 106.0	3.94 100.0		5.6250 142.875	0.8661 22.000	0.13 3.3	5.43 138.0	5.08 129.0	1.1811 30.000	
37500 167000	56500 252000	0.44 1.36	M719100 Series							JM719113							
			■ JM719149	3.7402 95.000	1.3386 34.000	0.12 3.0	-0.06 -1.5	4.29 109.0	4.09 104.0		5.9055 150.000	1.0630 27.000	0.10 2.5	5.63 143.0	5.31 135.0	1.3780 35.000	
52000 230000	81500 360000	0.47 1.28	HM720200 Series							JHM720210							
			■ JHM720249	3.9370 100.000	1.5748 40.000	0.12 3.0	-0.10 -2.5	4.61 117.0	4.29 109.0		6.2992 160.000	1.2598 32.000	0.10 2.5	6.06 154.0	5.63 143.0	1.6142 41.000	
42500 189000	68500 305000	0.47 1.27	M720200 Series							JM720210							
			■ JM720249	3.9370 100.000	1.3780 35.000	0.12 3.0	0.01 0.3	4.53 115.0	4.29 109.0		6.1024 155.000	1.1024 28.000	0.10 2.5	5.87 149.0	5.51 140.0	1.4173 36.000	
279000 1240000	470000 2100000	0.38 1.59	722000 Series							722185							
			EE722110	11.0000 279.400	3.6875 93.662	0.38 9.7	-0.30 -7.6	12.64 321.0	12.36 314.0		18.5000 469.900	2.7500 69.850	0.13 3.3	17.04 433.0	16.93 430.0	3.7500 95.250	
			EE722115	11.5000 292.100	3.6875 93.662	0.38 9.7	-0.30 -7.6	12.99 330.0	12.76 324.0								
79000 350000	148000 660000	0.44 1.37	M734400 Series							JM734410							
			■ JM734445	6.2992 160.000	1.7520 44.500	0.12 3.0	0.20 5.1	7.01 178.0	6.81 173.0		9.4488 240.000	1.4567 37.000	0.10 2.5	9.12 232.0	8.74 222.0	1.8110 46.000	
			■ JM734449	6.6929 170.000	1.7520 44.500	0.12 3.0	0.20 5.1	7.28 185.0	7.09 180.0								
81000 360000	155000 690000	0.48 1.25	M736100 Series							JM736110							
			■ JM736149	7.0866 180.000	1.7717 45.000	0.12 3.0	0.35 8.9	7.72 196.0	7.50 190.0		9.8425 250.000	1.4567 37.000	0.10 2.5	9.55 243.0	9.13 232.0	1.8504 47.000	
			■ JM736149AS	7.0866 180.000	1.7717 45.000	0.47 12.0	0.35 8.9	9.09 231.0	7.50 190.0								
80500 355000	158000 700000	0.48 1.26	M738200 Series							JM738210							
			■ JM738249	7.4803 190.000	1.7323 44.000	0.12 3.0	0.43 10.9	8.11 206.0	7.87 200.0		10.2362 260.000	1.4370 36.500	0.10 2.5	9.92 252.0	9.53 242.0	1.8110 46.000	
			■ JM738249A	7.4803 190.000	1.7323 44.000	0.31 8.0	0.43 10.9	8.46 215.0	7.87 200.0								

* The maximum fillet on the shaft or in the housing that the bearing corner will clear.

† Positive value indicates the effective load center is outside the backface of the cone.

▲ For additional "B" cup dimensions, see pages 173 to 174.

■ For parts with a "J" prefix, use metric tolerances given on page 199 and fitting practice given on page 201.

★ Designate bearings with hollow rollers and pinned-type retainers.

◆ Bearing is equipped with seals (and in some instances side rings).

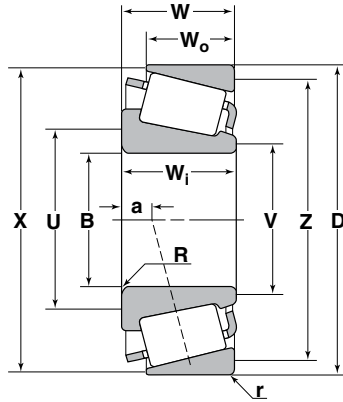

TS Type

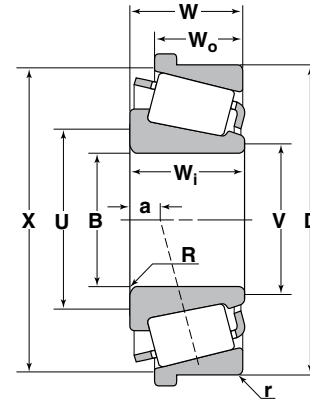

TSF Type

Basic Load Ratings		Axial Load Factor e Y_2	Cone Number	B	W_i	R	a	U	V	Cup Number	D	W_o	r	X	Z	W
Dynamic C_r	Static C_{or}			Bore Diameter	Cone Width	Maximum Shaft Fillet Radius *	Effective Load Center†	Minimum Shaft Shoulder Diameter	Minimum Shaft Shoulder Diameter		Outside Diameter	Cup Width	Maximum Housing Fillet Radius *	Maximum Housing Shoulder Diameter	Maximum Housing Shoulder Diameter	Bearing Width
lbs/N				Inch/mm						Inch/mm						
60500 269000	142000 630000	0.45 1.34	LM739700 Series													
			LM739749	7.7500 196.850	1.5625 39.688	0.14 3.5	0.45 11.4	8.39 213.0	8.11 206.0	LM739710	10.1250 257.175	1.1875 30.162	0.13 3.3	9.88 251.0	9.41 239.0	1.5625 39.688
			LM739719	10.5000 266.700	1.1875 30.162	0.13 3.3	9.92 252.0	9.57 243.0	1.5625 39.688							
81500 360000	176000 785000	0.48 1.25	LM742700 Series													
			LM742745	8.3750 212.725	1.8125 46.038	0.14 3.5	0.56 14.2	9.06 230.0	8.86 225.0	LM742710	11.2500 285.750	1.3750 34.925	0.13 3.3	10.98 279.0	10.47 266.0	1.8125 46.038
			LM742749	8.5000 215.900	1.8125 46.038	0.14 3.5	0.56 14.2	9.17 233.0	8.94 227.0	▲LM742710B	11.2500 285.750	1.3750 34.925	0.13 3.3	11.02 280.0	—	1.8125 46.038
			LM742749AA	8.5000 215.900	1.8125 46.038	0.35 8.9	0.56 14.2	10.04 255.0	8.94 227.0							
152000 675000	340000 1510000	0.44 1.36	LM757000 Series													
			LM757049	12.0000 304.800	2.5000 63.500	0.25 6.4	0.64 16.3	13.03 331.0	12.68 322.0	LM757010	16.0000 406.400	1.8750 47.625	0.13 3.3	15.47 393.0	14.96 380.0	2.5000 63.500
			LM757049AA	12.0000 304.800	2.5000 63.500	0.50 12.7	0.64 16.3	14.13 359.0	12.68 322.0	▲LM757010B	16.0000 406.400	1.8750 47.625	0.13 3.3	15.47 393.0	—	2.5000 63.500
50000 222000	133000 590000	0.44 1.36	LL758700 Series													
			LL758744	12.7500 323.850	1.1250 28.575	0.14 3.5	1.38 35.1	13.35 339.0	13.11 333.0	LL758715	15.0000 381.000	0.8125 20.638	0.13 3.3	14.69 373.0	14.37 365.0	1.1250 28.575
297000 1320000	670000 2980000	0.45 1.32	LM770900 Series													
			LM770945	17.7500 450.850	3.3125 84.138	0.25 6.4	1.20 30.5	18.86 479.0	18.11 460.0	LM770910	23.7500 603.250	2.3750 60.325	0.13 3.3	23.43 595.0	23.11 587.0	3.3750 85.725
			LM770949	18.0000 457.200	3.3125 84.138	0.25 6.4	1.20 30.5	19.13 486.0	18.35 466.0							
315000 1390000	735000 3250000	0.47 1.27	LM772700 Series													
			LM772748	19.2500 488.950	3.3125 84.138	0.25 6.4	1.61 40.8	20.35 517.0	19.61 498.0	LM772710	24.9950 634.873	2.4375 61.912	0.13 3.3	24.65 626.0	24.37 619.0	3.3125 84.137

* The maximum fillet on the shaft or in the housing that the bearing corner will clear.

† Positive value indicates the effective load center is outside the backface of the cone.

▲ For additional "B" cup dimensions, see pages 173 to 174.

■ For parts with a "J" prefix, use metric tolerances given on page 199 and fitting practice given on page 201.

★ Designate bearings with hollow rollers and pinned-type retainers.

◆ Bearing is equipped with seals (and in some instances side rings).

Basic Load Ratings		Axial Load Factor e Y ₂	Cone Number	B	W ₁	R	a	U	V	Cup Number	D	W _O	r	X	Z	W	
Dynamic C _r	Static C _{or}			Bore Diameter	Cone Width	Maximum Shaft Fillet Radius †	Effective Load Center†	Minimum Shaft Shoulder Diameter	Minimum Shaft Shoulder Diameter		Outside Diameter	Cup Width	Maximum Housing Fillet Radius †	Maximum Housing Shoulder Diameter	Maximum Housing Shoulder Diameter	Maximum Housing Shoulder Diameter	Bearing Width
lbs/N				Inch/mm								Inch/mm					
32000 141000	43500 194000	0.49 1.23	HM807000 Series														
			HM807035	1.6250 41.275	1.4375 36.512	0.06 1.5	-0.29 -7.4	2.36 60.0	2.24 57.0	HM807010	4.1250 104.775	1.1250 28.575	0.13 3.3	3.94 100.0	3.50 89.0	1.4375 36.512	
			HM807040	1.7500 44.450	1.4375 36.512	0.14 3.5	-0.29 -7.4	2.60 66.0	2.32 59.0	HM807011	4.1250 104.775	1.1250 28.575	0.03 0.8	3.94 100.0	3.58 91.0	1.4375 36.512	
			HM807044	1.9375 49.212	1.4375 36.512	0.14 3.5	-0.29 -7.4	2.72 69.0	2.48 63.0	■ JHM807012	4.1339 105.000	1.1417 29.000	0.10 2.5	3.94 100.0	3.54 90.0	1.4517 36.873	
			HM807046	2.0000 50.800	1.4375 36.512	0.14 3.5	-0.29 -7.4	2.76 70.0	2.48 63.0								
			HM807048	2.1452 54.448	1.4375 36.512	0.14 3.5	-0.29 -7.4	2.87 73.0	2.48 63.0								
			HM807049	2.1250 53.975	1.4375 36.512	0.14 3.5	-0.29 -7.4	2.87 73.0	2.48 63.0								
			HM807049A	2.1250 53.975	1.4375 36.512	0.06 1.5	-0.29 -7.4	2.72 69.0	2.48 63.0								
			■ JHM807045	1.9685 50.000	1.4173 36.000	0.12 3.0	-0.29 -7.4	2.72 69.0	2.48 63.0	HM807010	4.1250 104.775	1.1250 28.575	0.13 3.3	3.94 100.0	3.50 89.0	1.4425 36.640	
										HM807011	4.1250 104.775	1.1250 28.575	0.03 0.8	3.94 100.0	3.58 91.0	1.4425 36.640	
										■ JHM807012	4.1339 105.000	1.1417 29.000	0.10 2.5	3.94 100.0	3.54 90.0	1.4567 37.000	
15300 68000	19700 88000	0.49 1.23	L812100 Series														
			L812148	2.6250 66.675	0.6930 17.602	0.06 1.5	0.14 3.6	2.91 74.0	2.83 72.0	L812111	4.0635 103.213	0.4720 11.989	0.03 0.8	3.90 99.0	3.78 96.0	0.6930 17.602	
21400 95000	33000 146000	0.49 1.23	LM813000 Series														
			■ JLM813049	2.7559 70.000	0.9843 25.000	0.04 1.0	0.01 0.3	3.07 78.0	3.03 77.0	■ JLM813010	4.3307 110.000	0.8071 20.500	0.10 2.5	4.13 105.0	3.86 98.0	1.0236 26.000	
36000 160000	50000 223000	0.50 1.20	HM813800 Series														
			HM813839	2.3617 59.987	1.4375 36.512	0.14 3.5	-0.15 -3.8	3.15 80.0	2.87 73.0	HM813810	5.0000 127.000	1.0625 26.988	0.13 3.3	4.76 121.0	4.37 111.0	1.4375 36.512	
			HM813840	2.1875 55.562	1.4375 36.512	0.14 3.5	-0.15 -3.8	2.99 76.0	2.76 70.0	HM813811	5.0000 127.000	1.0625 26.988	0.06 1.5	4.76 121.0	4.45 113.0	1.4375 36.512	
			HM813841	2.3750 60.325	1.4375 36.512	0.14 3.5	-0.15 -3.8	3.15 80.0	2.87 73.0								
			HM813841A	2.3750 60.325	1.4375 36.512	0.06 1.5	-0.15 -3.8	2.99 76.0	2.87 73.0								
			HM813842	2.5000 63.500	1.4375 36.512	0.14 3.5	-0.15 -3.8	3.23 82.0	2.99 76.0								
			HM813842A	2.5000 63.500	1.4375 36.512	0.03 0.8	-0.15 -3.8	3.03 77.0	2.99 76.0								
			HM813844	2.6250 66.675	1.4375 36.512	0.14 3.5	-0.15 -3.8	3.35 85.0	3.07 78.0								
			HM813846	2.7500 69.850	1.4375 36.512	0.14 3.5	-0.15 -3.8	3.43 87.0	3.11 79.0								
			HM813849	2.8125 71.438	1.4375 36.512	0.14 3.5	-0.15 -3.8	3.50 89.0	3.22 82.0								

* The maximum fillet on the shaft or in the housing that the bearing corner will clear.

† Positive value indicates the effective load center is outside the backface of the cone.

▲ For additional "B" cup dimensions, see pages 173 to 174.

■ For parts with a "J" prefix, use metric tolerances given on page 199 and fitting practice given on page 201.

★ Designate bearings with hollow rollers and pinned-type retainers.

◆ Bearing is equipped with seals (and in some instances side rings).

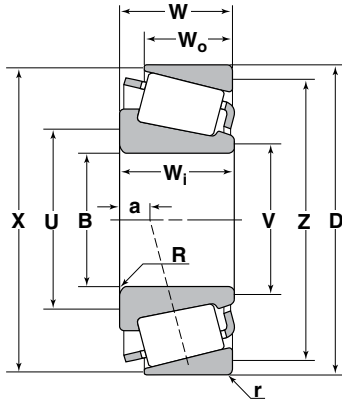

TS Type

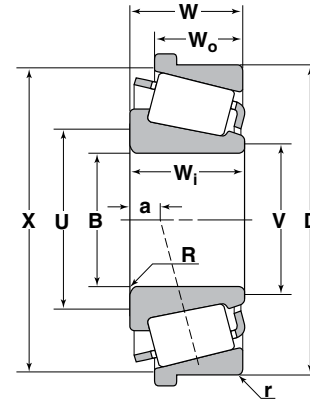

TSF Type

Basic Load Ratings		Axial Load Factor e Y_2	Cone Number	B	W_i	R	a	U	V	Cup Number	D	W_o	r	X	Z	W
Dynamic C_r	Static C_{or}			Bore Diameter	Cone Width	Maximum Shaft Fillet Radius *	Effective Load Center†	Minimum Shaft Shoulder Diameter	Minimum Shaft Shoulder Diameter		Outside Diameter	Cup Width	Maximum Housing Fillet Radius *	Maximum Housing Shoulder Diameter	Maximum Housing Shoulder Diameter	Bearing Width
lbs/N				Inch/mm						Inch/mm						
61500 275000	82000 365000	0.49 1.23	HH814500 Series													
			HH814542	2.3750 60.325	2.0750 52.705	0.14 3.5	-0.43 -10.9	3.50 89.0	3.27 83.0	HH814510	6.0000 152.400	1.6250 41.275	0.13 3.3	5.63 143.0	5.12 130.0	2.0750 52.705
			HH814547	2.6250 66.675	2.2500 57.150	0.14 3.5	-0.48 -12.2	3.74 95.0	3.50 89.0							
22400 99500	36000 160000	0.51 1.18	LM814800 Series													
			LM814849	3.0625 77.788	1.0000 25.400	0.14 3.5	0.09 2.3	3.58 91.0	3.35 85.0	LM814810	4.6250 117.475	0.7500 19.050	0.13 3.3	4.45 113.0	4.13 105.0	1.0000 25.400
										▲LM814810B	4.6250 117.475	0.7500 19.050	0.13 3.3	4.57 116.0	—	1.0000 25.400
42500 189000	69500 310000	0.50 1.21	M822000 Series													
			■ JM822049	4.3307 110.000	1.3780 35.000	0.12 3.0	0.12 3.0	4.88 124.0	4.69 119.0	■ JM822010	6.4961 165.000	1.0433 26.500	0.10 2.5	6.26 159.0	5.87 149.0	1.3780 35.000
227000 1010000	405000 1790000	0.58 1.04	HH840200 Series													
			HH840249	7.5000 190.500	3.7500 95.250	0.25 6.4	-0.22 -5.6	9.21 234.0	8.49 216.0	HH840210	13.2500 336.550	2.8750 73.025	0.25 6.4	12.52 318.0	11.42 290.0	3.8750 98.425
135000 600000	247000 1100000	0.52 1.15	HM840400 Series													
			■ JHM840449	7.8740 200.000	2.4409 62.000	0.14 3.5	0.32 8.1	8.78 223.0	8.45 215.0	■ JHM840410	11.8110 300.000	2.0079 51.000	0.10 2.5	11.37 289.0	10.75 273.0	2.5591 65.000
385000 1720000	825000 3650000	0.58 1.04	H859000 Series													
			H859049	12.3750 314.325	4.6875 119.062	0.25 6.4	0.33 8.4	14.21 361.0	13.57 345.0	H859010	19.5000 495.300	3.5000 88.900	0.25 6.4	18.62 473.0	17.28 439.0	4.7500 120.650
98500 435000	235000 1040000	0.50 1.20	L860000 Series													
			L860048	13.0000 330.200	1.8750 47.625	0.50 12.7	1.39 35.3	14.45 367.0	13.58 345.0	L860010	16.3750 415.925	1.3750 34.925	0.13 3.3	15.83 402.0	15.51 394.0	1.8750 47.625
			L860049	13.0000 330.200	1.8750 47.625	0.14 3.5	1.39 35.3	13.74 349.0	13.58 345.0							

* The maximum fillet on the shaft or in the housing that the bearing corner will clear.

† Positive value indicates the effective load center is outside the backface of the cone.

▲ For additional "B" cup dimensions, see pages 173 to 174.

■ For parts with a "J" prefix, use metric tolerances given on page 199 and fitting practice given on page 201.

★ Designate bearings with hollow rollers and pinned-type retainers.

◆ Bearing is equipped with seals (and in some instances side rings).

Basic Load Ratings		Axial Load Factor e Y_2	Cone Number	B	W_f	R	a	U	V	Cup Number	D	W_o	r	X	Z	W
Dynamic C_r	Static C_{or}			Bore Diameter	Cone Width	Maximum Shaft Fillet Radius *	Effective Load Center†	Minimum Shaft Shoulder Diameter	Minimum Shaft Shoulder Diameter		Outside Diameter	Cup Width	Maximum Housing Fillet Radius *	Maximum Housing Shoulder Diameter	Maximum Housing Shoulder Diameter	Bearing Width
lbs/N				Inch/mm						Inch/mm						
32000 142000	37000 165000	0.82 0.73	HM911200 Series													
			HM911242	2.1250 53.975	1.3125 33.338	0.14 3.5	0.21 5.3	3.11 79.0	2.91 74.0	HM911210	5.1250 130.175	0.9375 23.812	0.13 3.3	4.87 124.0	4.29 109.0	1.4375 36.512
			HM911245	2.3750 60.325	1.3125 33.338	0.20 5.0	0.21 5.3	3.43 87.0	2.91 74.0	■ JHM911211	5.1181 130.000	0.8917 22.650	0.13 3.3	4.84 123.0	4.29 109.0	1.4375 36.512
			HM911249	2.4375 61.912	1.3125 33.338	0.14 3.5	0.21 5.3	3.35 85.0	2.91 74.0	HM911216	5.3143 134.983	0.8641 21.948	0.14 3.5	4.84 123.0	4.41 112.0	1.4119 35.862
			■ JHM911244	2.3622 60.000	1.2175 30.924	0.14 3.5	0.31 7.9	3.31 84.0	2.91 74.0	HM911210	5.1250 130.175	0.9375 23.812	0.13 3.3	4.87 124.0	4.29 109.0	1.3425 34.100
										■ JHM911211	5.1181 130.000	0.8917 22.650	0.13 3.3	4.84 123.0	4.29 109.0	1.3425 34.100
										HM911216	5.3143 134.983	0.8641 21.948	0.14 3.5	4.84 123.0	4.41 112.0	1.3169 33.449
43500 193000	51000 226000	0.78 0.77	H913800 Series													
			H913840	2.3617 59.987	1.5625 39.688	0.14 3.5	0.17 4.3	3.46 88.0	3.24 82.0	H913810	5.7500 146.050	1.0000 25.400	0.13 3.3	5.43 138.0	4.88 124.0	1.6250 41.275
			H913842	2.4375 61.912	1.5625 39.688	0.14 3.5	0.17 4.3	3.54 90.0	3.24 82.0	■ JH913811	5.9055 150.000	1.0000 25.400	0.13 3.3	5.75 146.0	4.96 126.0	1.6250 41.275
			■ JH913848	2.7559 70.000	1.5625 39.688	0.08 2.0	0.17 4.3	3.62 92.0	3.24 82.0							
			H913849	2.7500 69.850	1.5625 39.688	0.14 3.5	0.17 4.3	3.74 95.0	3.24 82.0							
71500 320000	82000 365000	0.80 0.75	HH914400 Series													
			HH914447	2.5000 63.500	2.1250 53.975	0.14 3.5	-0.01 -0.3	4.13 105.0	3.35 85.0	HH914412	7.0000 177.800	1.4688 37.308	0.13 3.3	6.50 165.0	5.75 146.0	2.2500 57.150
			HH914449	2.6250 66.675	2.1250 53.975	0.14 3.5	-0.01 -0.3	4.17 106.0	3.36 85.0							
71500 320000	90000 400000	0.70 0.86	H916600 Series													
			H916642	2.7554 69.987	2.0938 53.183	0.13 3.3	-0.08 -0.2	4.06 103.0	3.74 95.0	H916610	6.9375 176.212	1.4375 36.512	0.13 3.3	6.46 164.0	5.79 147.0	2.1563 54.770
69000 305000	89500 395000	0.79 0.75	H919900 Series													
			H919942	3.3125 84.138	1.9291 49.000	0.25 6.4	0.31 7.9	4.02 102.0	3.62 92.0	H919911	7.6250 193.675	1.3582 34.498	0.25 6.4	7.44 189.0	6.81 173.0	2.0472 52.000
128000 570000	160000 715000	0.70 0.86	HH923600 Series													
			HH923649	4.0000 101.600	2.8750 73.025	0.25 6.4	-0.13 -3.3	5.87 149.0	5.15 131.0	HH923610	9.8750 250.825	2.0000 50.800	0.25 6.4	9.01 229.0	8.15 207.0	3.0000 76.200
										HH923611	9.8750 250.825	2.0000 50.800	0.13 3.3	9.01 229.0	8.27 210.0	3.0000 76.200
171000 760000	219000 975000	0.63 0.95	HH926700 Series													
			HH926744	4.5000 114.300	3.2500 82.550	0.25 6.4	-0.26 -6.6	6.46 164.0	5.80 147.0	HH926710	10.7500 273.050	2.1250 53.975	0.25 6.4	9.97 253.0	9.06 230.0	3.2500 82.550
			HH926749	4.7500 120.650	3.2500 82.550	0.25 6.4	-0.26 -6.6	6.61 168.0	5.80 147.0	HH926716	11.0000 279.400	2.1250 53.975	0.25 6.4	9.97 253.0	9.17 233.0	3.2500 82.550

* The maximum fillet on the shaft or in the housing that the bearing corner will clear.
 † Positive value indicates the effective load center is outside the backface of the cone.
 ▲ For additional "B" cup dimensions, see pages 173 to 174.
 ■ For parts with a "J" prefix, use metric tolerances given on page 199 and fitting practice given on page 201.
 ★ Designate bearings with hollow rollers and pinned-type retainers.
 ◆ Bearing is equipped with seals (and in some instances side rings).

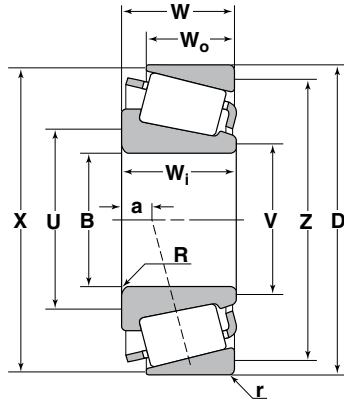

TS Type

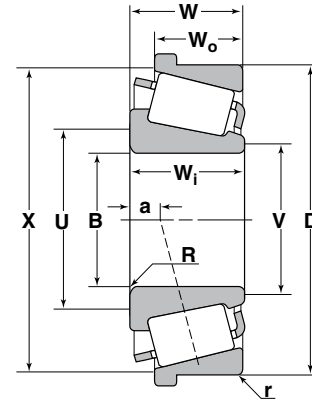

TSF Type

Basic Load Ratings		Axial Load Factor e Y_2	Cone Number	B	W_i	R	a	U	V	Cup Number	D	W_o	r	X	Z	W
Dynamic C_r	Static C_o			Bore Diameter	Cone Width	Maximum Shaft Fillet Radius †	Effective Load Center †	Minimum Shaft Shoulder Diameter	Minimum Shaft Shoulder Diameter		Outside Diameter	Cup Width	Maximum Housing Fillet Radius †	Maximum Housing Shoulder Diameter	Maximum Housing Shoulder Diameter	Bearing Width
lbs/N				Inch/mm						Inch/mm						
92000 410000	132000 585000	0.74 0.81	HM926700 Series													
			HM926740	4.5000 114.300	1.9460 49.428	0.14 3.5	0.53 13.5	5.75 146.0	5.59 142.0	HM926710	9.0000 228.600	1.5000 38.100	0.13 3.3	8.63 219.0	7.87 200.0	2.1250 53.975
			HM926747	5.0000 127.000	1.9460 49.428	0.14 3.5	0.53 13.5	6.14 156.0	5.63 143.0							
			HM926749	5.0312 127.792	1.9460 49.428	0.14 3.5	0.53 13.5	6.14 156.0	5.63 143.0							
184000 820000	253000 1130000	0.73 0.82	HH932100 Series													
			HH932132	5.0000 127.000	3.2500 82.550	0.25 6.4	0.07 1.8	7.17 182.0	6.77 172.0	HH932110	12.0000 304.800	2.2500 57.150	0.25 6.4	11.34 288.0	10.24 260.0	3.5000 88.900
			HH932145	5.7500 146.050	3.2500 82.550	0.25 6.4	0.07 1.8	7.68 195.0	6.87 174.0	HH932115	12.2500 311.150	2.2500 57.150	0.25 6.4	11.34 288.0	10.31 262.0	3.5000 88.900
193000 860000	278000 1240000	0.81 0.74	H936300 Series													
			H936349	6.6250 168.275	3.1250 79.375	0.25 6.4	0.67 16.9	7.76 197.0	6.97 177.0	H936310	13.0000 330.200	2.1250 53.975	0.25 6.4	12.68 322	11.89 302.0	3.3750 85.725
241000 1070000	405000 1800000	1.17 0.51	M959400 Series													
			★ M959442	12.0000 304.800	3.1250 79.375	0.25 6.4	4.10 104.2	13.11 333.0	12.32 313.0	M959410	19.6830 499.948	2.1250 53.975	0.25 6.4	19.06 484.0	18.58 472.0	4.0000 101.600
735000	385000 1710000	0.71 0.84	LM961500 Series													
			LM961548	13.5000 342.900	2.5000 63.500	0.13 3.3	2.22 56.4	14.45 367.0	14.29 363.0	LM961511	17.9960 457.098	1.8750 47.625	0.13 3.3	17.44 443.0	16.65 423.0	2.6875 68.262

- * The maximum fillet on the shaft or in the housing that the bearing corner will clear.
- † Positive value indicates the effective load center is outside the backface of the cone.
- ▲ For additional "B" cup dimensions, see pages 173 to 174.
- For parts with a "J" prefix, use metric tolerances given on page 199 and fitting practice given on page 201.
- ★ Designate bearings with hollow rollers and pinned-type retainers.
- ◆ Bearing is equipped with seals (and in some instances side rings).

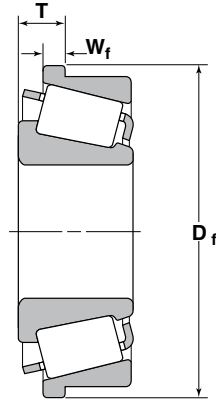

TSF Type

Cone Number	Cup Number	D _f	W _f	T
		Flange Diameter	Flange Width	Bearing Standout
		Inch/mm		
365	362B	3.7268 94.661	0.1875 4.762	0.3499 8.887
385	382B	3.9960 101.498	0.1875 4.762	0.3125 7.938
390	394AB	4.5147 114.673	0.1870 4.750	0.3120 7.925
395CS	394AB	4.5147 114.673	0.1870 4.750	0.3690 9.373
395ES	394AB	4.5147 114.673	0.1870 4.750	0.6520 16.561
455	453B	4.4640 113.386	0.2188 5.558	0.4376 11.115
475	472B	4.9384 125.435	0.2180 5.537	0.4368 11.095
495	493B	5.5890 141.961	0.2180 5.537	0.5305 13.475
525	522B	4.2460 107.848	0.2500 6.350	0.5625 14.288
537	532B	4.6210 117.373	0.2500 6.350	0.5625 14.288
554	552B	5.1210 130.073	0.2500 6.350	0.5625 14.288
554	553BA	5.2460 133.248	0.2500 6.350	0.2810 7.137
565	563B	5.2460 133.248	0.2500 6.350	0.5625 14.288
575	572B	5.7575 146.240	0.2500 6.350	0.5625 14.288
590A	592B	6.2460 158.648	0.2500 6.350	0.6250 15.875
615	612B	5.0272 127.691	0.2812 7.142	0.6562 16.667
615	613B	5.0272 127.691	0.2500 6.350	0.5000 12.700
636	632B	5.6520 143.561	0.2810 7.137	0.6560 16.662
655	652B	6.2772 159.441	0.2812 7.142	0.6562 16.667
662	652B	6.2772 159.441	0.2812 7.142	0.5312 13.492

Cone Number	Cup Number	D _f	W _f	T
		Flange Diameter	Flange Width	Bearing Standout
		Inch/mm		
677	672B	6.9030 175.336	0.2812 7.142	0.7187 18.255
740	742B	6.2170 157.912	0.3125 7.938	0.6250 15.875
755	752B	6.6830 169.748	0.3120 7.925	0.6870 17.450
776	772B	7.4330 188.798	0.3125 7.938	0.6875 17.462
795	792B	8.4336 214.213	0.3125 7.938	0.8125 20.638
835	832B	6.9960 177.698	0.3750 9.525	0.8750 22.225
855	854B	7.8710 199.923	0.3750 9.525	0.8750 22.225
896	892B	9.3710 238.023	0.3750 9.525	0.8750 22.225
936	932B	8.8085 223.736	0.4375 11.112	0.9375 23.812
3767	3720B	3.8558 97.937	0.1875 4.762	0.4375 11.112
3975	3920B	4.6210 117.373	0.1875 4.762	0.4375 11.112
6460	6420B	6.1835 157.061	0.3125 7.938	0.6875 17.462
6559C	6535B	6.7500 171.450	0.3125 7.938	0.7500 19.050
8573	8520B	13.2460 336.448	0.3750 9.525	1.0000 25.400
9380	9321B	7.0620 179.375	0.3125 7.938	1.0000 25.400
■ JP10044	■ JP10010B	5.9843 152.000	0.1575 4.000	0.4134 10.500
27684	27620B	5.1211 130.076	0.1875 4.762	0.4062 10.317
29580	29520B	4.4022 111.816	0.1563 3.970	0.4063 10.320
29580	29521B	4.4803 113.800	0.1563 3.970	0.4063 10.320
29675	29620B	4.5900 116.586	0.1563 3.970	0.4063 10.320
33225	33462B	4.8084 122.133	0.1875 4.762	0.4375 11.112
34274	34478B	4.9648 126.106	0.1875 4.762	0.4688 11.908
36690	36620B	7.7772 197.541	0.1563 3.970	0.3750 9.525
37425	37625B	6.4336 163.413	0.1875 4.762	0.4688 11.908
39250	39412B	4.3084 109.433	0.1875 4.762	0.4063 10.320
39573	39520B	4.6523 118.168	0.2188 5.558	0.4688 11.908
42346	42587B	6.0898 154.681	0.2188 5.558	0.5000 12.700
42687	42620B	5.2460 133.248	0.2188 5.558	0.5313 13.495
46780	46720B	9.0898 230.881	0.2188 5.558	0.5313 13.495

■ For parts with a "J" prefix, use metric tolerances given on page 199 and fitting practice given on page 201.

Cone Number	Cup Number	D _f	W _f	T
		Flange Diameter	Flange Width	Bearing Standout
		Inch/mm		
47685	47620B	5.4650	0.2188	0.5000
		138.811	5.558	12.700
47890	47825B	5.8710	0.3125	0.5937
		149.123	7.938	15.080
48286	48220B	7.4335	0.2500	0.5000
		188.811	6.350	12.700
48385	48320B	7.7148	0.2188	0.4688
		195.956	5.558	11.908
48684	48620B	8.0898	0.2187	0.5000
		205.481	5.555	12.700
49576	49520B	4.2148	0.2188	0.4688
		107.056	5.558	11.908
52375	52637B	6.6210	0.2500	0.6562
		168.173	6.350	16.667
55175C	55437B	4.5938	0.2188	0.5938
		116.683	5.558	15.083
56418	56650B	6.7460	0.2500	0.6250
		171.348	6.350	15.875
59200	59414B	4.6063	0.1563	0.4688
		117.000	3.970	11.907
59200	59429B	4.5360	0.2500	0.5625
		115.214	6.35	14.287
64432	64700B	7.2772	0.2813	0.7188
		184.841	7.145	18.258
65385	65320B	4.7772	0.2813	0.6563
		121.341	7.145	16.670
65200	65500B	5.2772	0.2813	0.6563
		134.041	7.145	16.670
66200	66462B	4.8750	0.2500	0.6250
		123.825	6.350	15.875
67388	67320B	8.2772	0.2813	0.5938
		210.241	7.145	15.083
67388	67322B	8.0272	0.2813	0.5938
		203.891	7.145	15.083
67780	67720B	10.0272	0.2813	0.6563
		254.691	7.145	16.670
67883	67820B	10.7772	0.2813	0.6563
		273.741	7.145	16.670
67983	67920B	11.4022	0.2813	0.6563
		289.616	7.145	16.670
68450	68712B	7.4022	0.2813	0.6563
		188.016	7.145	16.670
71412	71750B	7.8080	0.3125	0.8125
		198.323	7.938	20.638
74500	74850B	8.8084	0.3125	0.8125
		223.733	7.938	20.638
77350	77675B	7.0584	0.3125	0.6875
		179.283	7.938	17.462
82550	82950B	9.8710	0.3750	0.8750
		250.723	9.525	22.225
87737	87111B	11.4960	0.3750	0.9375
		292.000	9.525	23.812
93708	93125B	12.9340	0.4375	1.1250
		328.524	11.112	28.575
94649	94113B	11.8084	0.4375	1.0625
		299.933	11.112	26.988
95475	95925B	9.6834	0.4375	1.0000
		245.958	11.112	25.400

Cone Number	Cup Number	D _f	W _f	T
		Flange Diameter	Flange Width	Bearing Standout
		Inch/mm		
96900	96140B	14.4340	0.4375	1.2500
		366.624	11.112	31.750
98316	98788B	8.2500	0.3750	1.0772
		209.550	9.525	27.361
99550	99100B	10.4320	0.4375	1.1875
		264.973	11.112	30.162
EE128111	128160B	16.4960	0.5000	1.1250
		418.998	12.700	28.575
HH221430	HH221410B	7.8710	0.4375	0.8750
		199.923	11.112	22.225
HM231140	HM231115B	9.8710	0.3750	0.8750
		250.723	9.525	22.225
EE231400	232000B	20.5586	0.5625	1.5000
		522.188	14.288	38.100
HM237532	HM237510B	11.8084	0.4375	1.0625
		299.933	11.112	26.988
M249732	M249710B	14.6250	0.5000	1.1875
		371.475	12.700	30.162
L305649	L305610B	3.3085	0.1250	0.2813
		84.036	3.175	7.145
L357049	L357019B	16.5324	0.3750	0.8750
		419.923	9.525	22.225
H414235	H414210B	5.6550	0.12800	0.6550
		143.637	7.112	16.637
LM451345	LM451310B	14.3750	0.3750	0.8750
		365.125	9.525	22.225
HM516442	HM516414B	5.6875	0.2038	0.4850
		144.462	5.177	12.319
EE526130	526190B	19.6210	0.6250	1.6250
		498.373	15.875	41.275
LM545849	LM545810B	13.3125	0.3250	0.8250
		338.137	8.255	20.955
LM613449	LM613410B	4.6875	0.1875	0.4375
		119.062	4.762	11.112
L624549	L624510B	6.4647	0.1563	0.3438
		164.203	3.970	8.733
L630349	L630310B	7.7705	0.1562	0.3925
		197.371	3.967	9.970
LM654642	LM654610B	15.3710	0.3750	1.0000
		390.423	9.525	25.400
H715332	H715310B	6.0000	0.3125	0.6875
		152.400	7.938	17.462
■ JM716648	■ JM716610B	5.3346	0.2188	0.4550
		135.500	5.558	11.557
LM742745	LM742710B	11.5624	0.3125	0.7500
		293.685	7.938	19.050
LM757049	LM757010B	16.5000	0.3750	1.0000
		419.100	9.525	25.400
LM814849	LM814810B	4.8084	0.1875	0.4375
		122.133	4.762	11.112

■ For parts with a "J" prefix, use metric tolerances given on page 199 and fitting practice given on page 201.

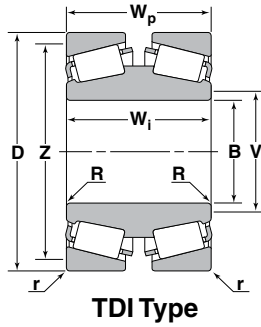

TDI Type

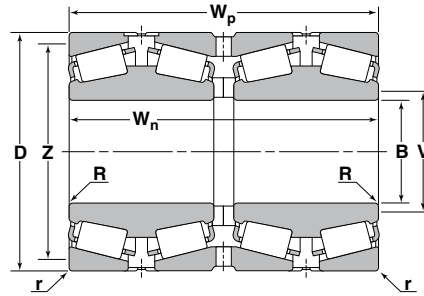

TQO Type

Basic Load Ratings				Axial Load Factors e Y ₁ Y ₂	Cone Number	B	W _i	R	V	Cup Number	D	r	Z	W _n	W _p
Two Row		Four Row				Bore Diameter	Cone Width	Maximum Shaft Fillet Radius *	Minimum Shaft Shoulder Diameter		Outside Diameter	Maximum Housing Fillet Radius *	Maximum Housing Shoulder Diameter	Bearing Width Through Cones	Bearing Width Over Cups
Dynamic	Static	Dynamic	Static			Inch/mm					Inch/mm				
lbs/N						Inch/mm				Inch/mm					
				0.51	67900 Series										
137000	345000	236000	690000	1.32	67986DW	8.1250 206.375	3.5625 90.483	0.03 0.8	8.35 212.0	67920	11.1250 282.575	0.13 3.3	10.24 260.0	— —	3.4375 87.312
610000	1540000	1050000	3100000	1.97	67986DW	8.1250 206.375	— —	0.03 0.8	8.35 212.0	67920	11.1250 282.575	0.13 3.3	10.24 260.0	7.5000 190.500	7.5000 190.500
					67921D	11.1250 282.575	— —	— —	— —						
				0.49	74000 Series										
122000	241000	—	—	1.38	74512D	5.1250 130.175	4.0000 101.600	0.06 1.5	5.47 139.0	74850	8.5000 215.900	0.13 3.3	7.72 196.0	— —	4.0000 101.600
545000	1070000	—	—	2.06											
				0.35	127000 Series										
222000	485000	380000	965000	1.14	EE127094D	9.4970 241.224	4.2500 107.950	0.06 1.5	10.12 257.0	127138	13.9960 355.498	0.13 3.3	12.87 327.0	— —	4.2500 107.950
985000	2150000	1690000	4300000	1.70	EE127094D	3.4970 241.224	— —	0.06 1.5	10.12 257.0	127138	13.9960 355.498	0.13 3.3	12.87 327.0	9.0000 228.600	9.0000 228.600
					127139D	13.9960 355.498	— —	— —	— —						
				0.38	135000 Series										
345000	775000	590000	1550000	1.77	EE135111DW	11.0000 279.400	5.0000 127.000	0.06 1.5	11.34 288.0	135155	15.5000 393.700	0.25 6.4	14.37 365.0	— —	5.0000 127.000
1530000	3450000	2620000	6900000	2.64	EE135111DW	11.0000 279.400	— —	0.03 1.5	11.34 288.0	135155	15.5000 393.700	0.25 6.4	14.37 365.0	10.6250 269.875	10.6250 269.875
					135156D	15.5000 393.700	— —	— —	— —						
				0.33	M257100 Series										
345000	805000	590000	1610000	1.21	M257149D	12.0000 304.800	5.1250 130.175	0.06 1.5	12.68 322.0	M257110	16.5000 419.100	0.25 6.4	15.43 392.0	— —	5.1250 130.175
1530000	3600000	2620000	7150000	1.80	M257149DW	12.0000 304.800	5.1250 130.175	0.06 1.5	12.68 322.0	M257110	16.5000 419.100	0.25 6.4	15.43 392.0	10.6250 269.875	10.6250 269.875
					M257149D	12.0000 304.800	— —	0.06 1.5	12.68 322.0	M257110D	16.5000 419.100	— —	— —	— —	— —
				0.32	LM258600 Series										
330000	855000	565000	1710000	1.26	LM258648DW	12.5000 317.500	5.0625 128.588	0.06 1.5	13.15 334.0	LM258610	16.6250 422.275	0.13 3.3	15.67 398.0	— —	5.0625 128.588
1470000	3800000	2510000	7650000	1.88	LM258648DW	12.5000 317.500	— —	0.06 1.5	13.15 334.0	LM258610	16.6250 422.275	0.13 3.3	15.67 398.0	10.6250 269.875	10.6250 269.875
					LM258610D	16.6250 422.275	— —	— —	— —						

* The maximum fillet on the shaft or in the housing that the bearing corner will clear.

Basic Load Ratings				Axial Load Factors e Y ₁ Y ₂	Cone Number	B	W _i	R	V	Cup Number	D	r	Z	W _n	W _p
Two Row		Four Row				Bore Diameter	Cone Width	Maximum Shaft Fillet Radius *	Minimum Shaft Shoulder Diameter		Outside Diameter	Maximum Housing Fillet Radius *	Maximum Housing Shoulder Diameter	Bearing Width Through Cones	Bearing Width Over Cups
Dynamic	Static	Dynamic	Static			Inch/mm					Inch/mm				
lbs/N															
710000		1810000		0.33	HM266400 Series										
3150000		8050000		2.03	HM266449DW	15.1250	7.6250	0.13	15.75	HM266410	21.5000	0.25	20.39	—	7.6250
				3.02		384.175	193.675	3.3	400.0		546.100	6.4	518.0	—	193.675
460000		1290000		0.32	BT272000 Series										
2040000		5700000		2.12	BT272049DGA	15.3543	6.8898	0.06	15.71	■ JBT272010	20.0787	0.12	19.49	—	5.8662
				3.15		390.000	175.000	1.5	399.0		510.000	3.0	495.0	—	149.000
					◆ BT272049DGA	15.3543	—	0.06	15.71	■ JBT272010	20.0787	0.12	19.49	13.7795	13.7795
						390.000	—	1.5	399.0		510.000	3.0	495.0	350.000	350.000
											20.0787	—	—	—	—
											510.000	—	—	—	—
575000		1640000		0.33	LM272200 Series										
2560000		7300000		2.03	LM272249DW	19.0000	6.2500	0.13	19.61	LM272210	24.2500	0.25	23.15	—	6.2500
				3.02		482.600	158.750	3.3	498.0		615.950	6.4	588.0	—	158.750
					LM272249DW	19.0000	—	0.13	19.61	LM272210	24.2500	0.25	23.15	13.0000	13.0000
						482.600	—	3.3	498.0		615.950	6.4	588.0	330.200	330.200
											24.2500	—	—	—	—
											615.950	—	—	—	—
1100000		2920000		0.33	M272700 Series										
4900000		12950000		2.03	* M272749D	18.8750	9.3750	0.13	19.49	M272210	26.7500	0.25	25.63	—	9.3750
				3.02		479.725	238.125	3.3	495.0		679.450	6.4	651.0	—	238.125
825000		2630000		0.33	L281100 Series										
3650000		11700000		2.03	* L281100BN1XDGWA	26.0000	7.1875	0.13	26.61	L281110	32.0000	0.25	30.87	—	6.9375
				3.02		660.400	182.562	3.3	676.0		812.800	6.4	784.0	—	176.212
					* L281100BN1XDGWA	26.0000	—	0.13	26.61	L281110	32.0000	0.25	30.87	14.3750	14.3750
						660.400	—	3.3	676.0		812.800	6.4	784.0	365.125	365.125
											32.0000	—	—	—	—
											812.800	—	—	—	—
600000		1700000		0.32	BT281200 Series										
2670000		7550000		1.88	BT281249DGA	20.0787	7.4606	0.13	20.71	■ JBT281210	25.7874	0.13	25.16	—	6.2598
				3.15		510.000	189.500	3.3	526.0		655.000	3.3	635.0	—	159.000
					◆ BT281249DGA	20.0787	—	0.13	20.71	■ JBT281210	25.7874	0.13	25.16	14.9213	14.9213
						510.000	—	3.3	526.0		655.000	3.3	635.0	379.000	379.000
											25.7874	—	—	—	—
											655.000	—	—	—	—
420000		1090000		0.32	BT281400 Series										
1870000		4850000		1.88	BT281449DGA	19.0000	6.5000	0.13	19.61	BT281410	24.2500	0.25	23.15	—	4.9213
				3.15		482.600	165.100	3.3	498.0		615.950	6.4	588.0	—	125.000
					◆ BT281449DGA	19.0000	—	0.13	20.71	BT281410	24.2500	0.25	23.15	13.0000	13.0000
						482.600	—	3.3	498.0		615.950	6.4	588.0	330.200	330.200
											24.2500	—	—	—	—
											615.950	—	—	—	—

* The maximum fillet on the shaft or in the housing that the bearing corner will clear.

★ Designate bearings with hollow rollers and pinned-type retainers.

◆ Bearing is equipped with seals (and in some instances side rings).

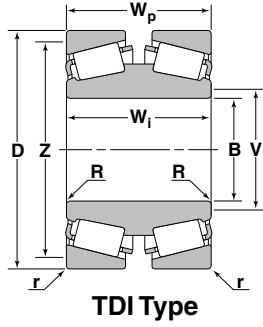

TDI Type

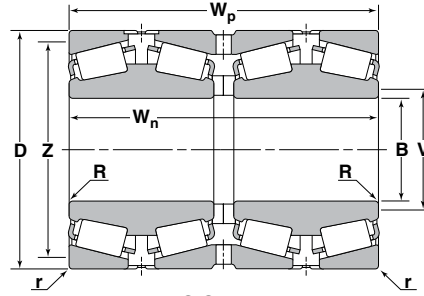

TQO Type

Basic Load Ratings				Axial Load Factors e Y ₁ Y ₂	Cone Number	B	W _i	R	V	Cup Number	D	r	Z	W _n	W _p		
Two Row		Four Row				Bore Diameter	Cone Width	Maximum Shaft Fillet Radius *	Minimum Shaft Shoulder Diameter		Outside Diameter	Maximum Housing Fillet Radius *	Maximum Housing Shoulder Diameter	Bearing Width Through Cones	Bearing Width Over Cups		
Dynamic	Static	Dynamic	Static			Inch/mm											
lbs/N						Inch/mm											
40100 178000	69800 310000	121600 540700	24700 110000	0.36	LM451300 Series	10.5000 266.700	4.3125 109.538	0.06 1.5	11.06 281.0	LM451310	14.0000 355.600	0.13 3.3	13.19 335.0	— —	4.2500 107.950		
				1.12	LM451349DW					LM451310						9.0625 230.188	9.0000 228.600
				1.67	LM451349DW					LM451310D						— —	— —
62800 279000	109000 486000	190400 846800	50800 226000	0.47	M757400 Series	11.9940 304.648	5.2813 134.145	0.13 3.3	12.91 328.0	M757410	17.2460 438.048	0.19 4.8	16.02 407.0	— —	5.4375 138.112		
				0.85	M757448DW					M757410						11.0626 280.990	11.0000 279.400
				1.27	M757449DW					M757410D						— —	— —
305000 1360000	735000 3250000	525000 2330000	1470000 6550000	0.47	LM761600 Series	13.4375 341.312	4.8125 122.238	0.06 1.5	14.13 359.0	LM761610	17.9960 457.098	0.13 3.3	17.36 441.0	— —	4.8125 122.238		
				1.43	LM761648DW					LM761610						10.0000 254.000	10.0000 254.000
				2.12	LM761649DW					LM761610D						— —	— —
305000 1360000	735000 3250000	525000 2330000	1470000 6550000	0.47	LM761648DW	13.5060 343.052	4.8125 122.238	0.06 1.5	14.21 361.0	LM761610	17.9960 457.098	0.13 3.3	17.36 441.0	10.0000 254.000	10.0000 254.000		
				1.43	LM761648DW					LM761610						— —	— —
				2.12	LM761649DWA					LM761610D						— —	— —

* The maximum fillet on the shaft or in the housing that the bearing corner will clear.
 ★ Designate bearings with hollow rollers and pinned-type retainers.

Basic Load Ratings				Axial Load Factors e Y ₁ Y ₂	Cone Number	B	W _i	R	V	Cup Number	D	r	Z	W _n	W _p
Two Row		Four Row				Bore Diameter	Cone Width	Maximum Shaft Fillet Radius *	Minimum Shaft Shoulder Diameter		Outside Diameter	Maximum Housing Fillet Radius *	Maximum Housing Shoulder Diameter	Bearing Width Through Cones	Bearing Width Over Cups
Dynamic	Static	Dynamic	Static								Inch/mm				
lbs/N						Inch/mm									
				0.47	LM763400 Series										
355000	850000	610000	1700000	0.85	LM763449DW	14.0000 355.600	5.0625 128.588	0.06 1.5	14.76 375.0	LM763410	19.0000 482.600	0.13 3.3	17.83 453.0	— —	5.2500 133.350
1590000	3800000	2720000	7600000	1.27	LM763449DW	14.0000 355.600	— —	0.06 1.5	14.76 375.0	LM763410	19.0000 482.600	0.13 3.3	17.83 453.0	10.4375 265.112	10.6250 269.875
					763449DWA	14.0000 355.600	— —	0.06 1.5	14.76 375.0	LM763410D	19.0000 482.600	— —	— —	— —	— —
					763449DWA	14.0000 355.600	— —	0.06 1.5	14.76 375.0	LM763410	19.0000 482.600	0.13 3.3	17.83 453.0	13.0000 330.200	10.6250 269.875
					LM763410D	19.0000 482.600	— —	— —	— —	LM763410D	19.0000 482.600	— —	— —	— —	— —
				0.47	L770800 Series										
475000	1200000	810000	2410000	1.43	L770849DW	18.0000 457.200	5.2500 133.350	0.06 1.5	18.35 466.0	L770810	23.5000 596.900	0.13 3.3	22.87 581.0	— —	5.3750 136.525
2110000	5350000	3600000	10700000	2.12	L770849DW	18.0000 457.200	— —	0.06 1.5	18.35 466.0	L770810	23.5000 596.900	0.13 3.3	22.87 581.0	10.8750 276.225	11.0000 279.400
					L770810D	23.5000 596.900	— —	— —	— —	L770810D	23.5000 596.900	— —	— —	— —	— —
				0.71	LM961500 Series										
284000	770000	485000	1540000	0.56	LM961548DW	13.5060 343.052	4.8125 122.238	0.06 1.5	14.29 363.0	LM961511	17.9960 457.098	0.13 3.5	16.65 423.0	— —	4.8750 123.825
1260000	3400000	2160000	6850000	0.84	LM961548DW	13.5060 343.052	— —	0.06 1.5	14.29 363.0	LM961511	17.9960 457.098	0.13 3.5	16.65 423.0	10.0000 254.000	10.0000 254.000
					LM961511D	17.9960 457.098	— —	— —	— —	LM961511D	17.9960 457.098	— —	— —	— —	— —
				1.01	BT981000 Series										
715000	1930000			0.67	*BT981049DW	20.0767 509.948	7.8750 200.025	0.20 5.1	20.98 533.0	BT981010	28.8750 733.425	0.20 5.1	27.95 710.0	— —	7.8450 199.263
3200000	8600000			0.99	*BT981049DW	20.0767 509.948	7.8750 200.025	0.20 5.1	20.98 533.0	BT981010	28.8750 733.425	0.20 5.1	27.95 710.0	— —	7.8450 199.263

* The maximum fillet on the shaft or in the housing that the bearing corner will clear.

★ Designate bearings with hollow rollers and pinned-type retainers.

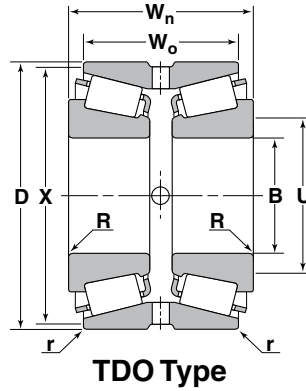

Basic Load Ratings		Axial Load Factors Y_1 Y_2	Cone Number †	B	R	U	Cup Number	D	W ₀	r	X	W _n
Dynamic C_r	Static C_{or}			Bore Diameter	Maximum Shaft Fillet Radius *	Minimum Shaft Shoulder Diameter		Outside Diameter	Cup Width	Maximum Housing Fillet Radius *	Maximum Housing Shoulder Diameter	Bearing Width Through Cones
lbs/N				Inch/mm				Inch/mm				
29300 130000	40500 81000	0.32 2.11 3.14	365 Series									
			365	1.9685 50.000	0.08 2.0	2.28 58.0	363D	3.5433 90.000	1.6563 42.070	0.03 0.8	3.34 85.0	1.9689 50.010
			366	1.9685 50.000	0.09 2.3	2.32 59.0						
			390	2.2500 57.150	0.09 2.3	2.76 70.0	394D	4.3307 110.000	1.8125 46.038	0.03 0.8	4.11 104.0	2.0625 52.388
31500 140000	48500 215000	0.40 1.68 2.50	455 Series									
			455	2.0000 55.000	0.03 0.8	2.36 60.0	452D	4.2500 107.950	2.1250 53.975	0.03 0.8	3.94 100.0	2.5626 65.090
43000 190000	63500 283000	0.34 2.01 3.00	475 Series									
			475	2.1654 55.000	0.03 0.8	2.64 67.0	472D	4.7244 120.000	2.1250 53.975	0.03 0.8	4.49 114.0	2.5626 65.090
45500 202000	72000 320000	0.38 1.75 2.61	495 Series									
			495	3.2500 82.550	0.14 3.5	3.82 97.0	493D	5.3750 136.525	2.1250 53.975	0.03 0.8	5.12 130.0	2.7500 69.850
49000 218000	83500 370000	0.44 1.52 2.26	555 Series									
			554	2.4375 61.912	0.14 3.5	3.03 77.0	552D	4.8750 123.825	2.5000 63.500	0.06 1.5	4.53 115.0	3.1250 79.375
60000 268000	95500 425000	0.35 1.95 2.90	565 Series									
			565	2.5000 63.500	0.14 3.5	3.15 80.0	563D	5.0000 127.000	2.5625 65.088	0.06 1.5	4.69 119.0	3.1875 80.962
62000 276000	101000 450000	0.36 1.85 2.76	575 Series									
			575	3.0000 76.200	0.14 3.5	3.62 92.0	572D	5.5115 139.992	2.6250 66.675	0.03 0.8	5.24 133.0	3.2500 82.550
65500 291000	112000 500000	0.40 1.68 2.50	595 Series									
			590A	3.0000 76.200	0.14 3.5	3.74 95.0	592D	6.0000 152.400	2.5000 63.500	0.03 0.8	5.67 144.0	3.2500 82.550
68500 305000	123000 550000	0.44 1.53 2.28	635 Series									
			636	2.1250 53.975	0.14 3.5	2.87 73.0	632D	5.3750 136.525	3.0000 76.200	0.06 1.5	4.92 125.0	3.7500 95.250

* The maximum fillet on the shaft or in the housing that the bearing corner will clear.
 † Any cone within a series may be used with a double cup of the same series.
 Contact the NTN Application Engineering Department for possible changes in dimension W_n.

Basic Load Ratings		Axial Load Factors e Y ₁ Y ₂	Cone Number †	B	R	U	Cup Number	D	W _O	r	X	W _N
Dynamic C _r	Static C _{or}			Bore Diameter	Maximum Shaft Fillet Radius *	Minimum Shaft Shoulder Diameter		Outside Diameter	Cup Width	Maximum Housing Fillet Radius *	Maximum Housing Shoulder Diameter	Bearing Width Through Cones
lbs/N				Inch/mm				Inch/mm				
85500 380000	153000 680000	0.47 1.43 2.14	675 Series 677	3.3750 85.725	0.14 3.5	4.13 105.0	672D	6.6250 168.275	2.7500 69.850	0.03 0.8	6.30 160.0	3.6250 92.075
100000 445000	162000 720000	0.33 2.08 3.09	745 Series 740 749A	3.1875 80.962 3.2500 82.550	0.20 5.0 0.14 3.5	3.98 101.0 3.90 99.0	742D	6.1250 155.575	3.3750 85.725	0.06 1.5	5.63 143.0	4.0000 101.600
104000 460000	172000 765000	0.34 1.98 2.95	755 Series 755	3.0000 76.200	0.14 3.5	3.74 95.0	752D	6.3750 161.925	3.3750 85.725	0.06 1.5	5.91 150.0	4.1250 104.775
110000 485000	193000 855000	0.39 1.76 2.61	775 Series 776 782	3.7500 95.250 4.1250 104.775	0.14 3.5 0.14 3.5	4.49 114.0 4.80 122.0	774D	7.1250 180.975	3.3750 85.725	0.06 1.5	6.61 168.0	4.1250 104.775
120000 535000	232000 1030000	0.46 1.47 2.19	795 Series 795	4.7500 120.650	0.13 3.3	5.47 139.0	792D	8.1250 206.375	3.2500 82.550	0.03 0.8	7.80 198.0	4.2500 107.950
147000 655000	250000 1110000	0.33 2.01 3.00	855 Series 855	3.5000 88.900	0.31 8.0	4.65 118.0	854D	7.5000 190.500	4.0000 101.600	0.06 1.5	6.85 174.0	5.0000 127.000
178000 790000	300000 1340000	0.33 2.07 3.08	935 Series 936	4.2500 107.950	0.31 8.0	5.39 137.0	932D	8.3750 212.725	4.6250 117.475	0.06 1.5	7.60 193.0	5.6250 142.875
38000 168000	58000 258000	0.34 1.99 2.97	3700 Series 3784	2.0000 50.800	0.25 6.4	2.76 70.0	3729D	3.6718 93.264	2.0625 52.388	0.03 0.8	3.46 88.0	2.5625 65.088
179000 795000	415000 1850000	0.41 1.66 2.47	8500 Series 8573	9.0000 228.600	0.25 6.4	10.04 255.0	8520D	12.8750 327.025	3.2500 82.550	0.06 1.5	12.32 313.0	4.5000 114.300
37000 164000	67000 298000	0.49 1.38 2.06	29600 Series 29675	2.7500 69.850	0.06 1.5	3.15 80.0	29622D	4.4995 114.287	1.8125 46.038	0.03 0.8	4.29 109.0	2.3125 58.737
64500 287000	157000 700000	0.37 1.83 2.73	36600 Series 36690	5.7500 146.050	0.06 1.5	6.10 155.0	36620D	7.6250 193.675	2.1250 53.975	0.03 0.8	7.40 188.0	2.5624 65.084
52500 233000	94500 420000	0.49 1.37 2.04	42000 Series 42381	3.8125 96.838	0.14 3.5	4.33 110.0	42587D	5.8750 149.225	2.0625 52.388	0.03 0.8	5.63 143.0	2.6249 66.672
97500 435000	249000 1110000	0.38 1.77 2.63	46700 Series 46780	6.2500 158.750	0.14 3.5	6.93 176.0	46720D	8.8750 225.425	2.7500 69.850	0.03 0.8	8.58 218.0	3.3750 85.725
86000 385000	194000 865000	0.31 2.22 3.30	48200 Series 48286	4.8750 123.825	0.14 3.5	5.47 139.0	48220D	7.1875 182.562	2.8750 73.025	0.03 0.8	6.93 176.0	3.3750 85.725

* The maximum fillet on the shaft or in the housing that the bearing corner will clear.

† Any cone within a series may be used with a double cup of the same series.

Contact the NTN Application Engineering Department for possible changes in dimension W_N.

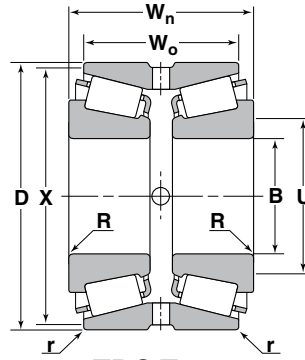

TDO Type

Basic Load Ratings		Axial Load Factors e Y_1 Y_2	Cone Number †	B	R	U	Cup Number	D	Wo	r	X	Wn	
Dynamic C_r	Static C_{or}			Bore Diameter	Maximum Shaft Fillet Radius *	Minimum Shaft Shoulder Diameter		Outside Diameter	Cup Width	Maximum Housing Fillet Radius *	Maximum Housing Shoulder Diameter	Bearing Width Through Cones	
lbs/N				Inch/mm				Inch/mm					
91000 405000	212000 945000	0.32 2.10 3.13	48385	5.2500	0.14	5.83	48320D	7.5000	2.8750	0.03	7.24	3.3750	
				133.350	3.5	148.0		190.500	73.025	0.8	184.0	85.725	
92000 410000	219000 975000	0.34 2.01 2.99	48684	5.6250	0.31	6.54	48620D	7.8750	2.8750	0.03	7.60	3.4376	
				142.875	8.0	166.0		200.025	73.025	0.8	193.0	87.315	
71500 320000	134000 595000	0.47 1.42 2.12	52375	3.7500	0.14	4.41	52637D	6.3750	2.4375	0.03	6.06	3.2499	
				95.250	3.5	112.0		161.925	61.912	0.8	154.0	82.547	
40000 179000	61500 274000	0.88 0.76 1.14	55175C	1.7500	0.14	2.76	55433D	4.3300	1.6875	0.02	4.13	2.5000	
				44.450	3.5	70.0		109.982	42.865	0.5	105.0	63.500	
73000 325000	139000 620000	0.50 1.36 2.02	56418	4.1875	0.14	4.80	56650D	6.5000	2.5000	0.03	6.26	3.2500	
				106.362	3.5	122.0		165.100	63.500	0.8	159.0	82.550	
50000 223000	70500 315000	0.67 1.01 1.51	66584	2.1250	0.14	2.95	66522D	5.1174	1.8750	0.03	4.65	2.7500	
				53.975	3.5	75.0		129.982	47.625	0.8	118.0	69.850	
117000 520000	244000 1080000	0.34 1.96 2.92	67388	5.0000	0.14	5.67	67322D	7.7500	3.3750	0.03	7.48	4.0000	
				127.000	3.5	144.0		196.850	85.725	0.8	190.0	101.600	
								67323D	7.7500	3.6250	0.03	7.48	4.2500
								67325D	196.850	92.075	0.8	190.0	107.950
							67325D	7.8750	3.3750	0.03	7.68	4.0000	
							200.025	85.725	0.8	195.0	101.600		
130000 575000	305000 1360000	0.44 1.54 2.29	67780	6.5000	0.14	7.28	67720D	9.7500	3.3125	0.03	9.45	4.0625	
				165.100	3.5	185.0		247.650	84.138	0.8	240.0	103.188	
135000 600000	330000 1460000	0.48 1.41 2.11	67883					10.5000	3.3125	0.03	10.20	4.0625	
								266.700	84.138	0.8	259.0	103.188	

* The maximum fillet on the shaft or in the housing that the bearing corner will clear.
 † Any cone within a series may be used with a double cup of the same series.
 Contact the NTN Application Engineering Department for possible changes in dimension W_n .

Basic Load Ratings		Axial Load Factors e Y ₁ Y ₂	Cone Number †	B	R	U	Cup Number	D	W _O	r	X	W _N
Dynamic C _r	Static C _{0r}			Bore Diameter	Maximum Shaft Fillet Radius *	Minimum Shaft Shoulder Diameter		Outside Diameter	Cup Width	Maximum Housing Fillet Radius *	Maximum Housing Shoulder Diameter	Bearing Width Through Cones
lbs/N				Inch/mm				Inch/mm				
137000 610000	345000 1540000	0.51 1.33 1.97	67900 Series 67983	8.0000 203.200	0.14 3.5	8.74 222.0	67920D	11.1250 282.575	3.2500 82.550	0.03 0.8	10.91 277.0	4.0000 101.600
116000 515000	212000 945000	0.42 1.62 2.41	71000 Series 71412	4.1250 104.775	0.14 3.5	4.88 124.0	71751D	7.5000 190.500	3.1875 80.962	0.06 1.5	7.13 181.0	4.1875 106.362
59500 265000	84500 375000	0.74 0.91 1.36	72000C Series 72225C	2.2500 57.150	0.14 3.5	3.19 81.0	72488D	4.8750 123.825	2.1875 55.562	0.06 1.5	4.57 116.0	3.0624 77.786
122000 545000	241000 1070000	0.49 1.38 2.06	74000 Series 74500	5.0000 127.000	0.14 3.5	5.83 148.0	74851D	8.5000 215.900	3.1875 80.962	0.06 1.5	8.19 208.0	4.1875 106.362
127000 565000	228000 1010000	0.35 1.92 2.86	81000 Series 81600	6.0000 152.400	0.14 3.5	6.73 171.0	81963D	9.6250 244.475	3.1250 79.375	0.06 1.5	9.00 228.0	4.2500 107.950
167000 740000	325000 1440000	0.44 1.53 2.28	82000 Series 82550	5.5000 139.700	0.14 3.5	6.34 161.0	82951D	9.5000 241.300	4.1875 106.362	0.06 1.5	8.90 226.0	5.1875 131.762
232000 1030000	500000 2230000	0.52 1.29 1.92	93000 Series 93708 93750	7.0856 179.974 7.5000 190.500	0.14 3.5 0.17 4.3	8.23 209.0 8.58 218.0	93127D	12.5000 317.500	4.3750 111.125	0.06 1.5	11.81 300.0	5.7500 146.050
207000 920000	415000 1850000	0.47 1.44 2.15	94000 Series 94649 94700	6.5000 165.100 7.0000 117.800	0.28 7.0 0.28 7.0	7.76 197.0 8.15 207.0	94114D 94118D	11.3750 288.925 11.7500 298.450	4.3750 111.125 4.3750 111.125	0.06 1.5 0.06 1.5	10.71 272.0 11.42 290.0	5.6250 142.875 5.6250 142.875
196000 875000	355000 1590000	0.37 1.82 2.71	95000 Series 95475	4.7500 120.650	0.25 6.4	5.87 149.0	95927D	9.2500 234.950	4.5000 114.300	0.06 1.5	8.54 217.0	5.6250 142.875
241000 1070000	550000 2460000	0.59 1.15 1.71	96000 Series 96900	9.0000 228.600	0.28 7.0	10.24 260.0	96140D	14.0000 355.600	4.3750 111.125	0.06 1.5	13.15 334.0	6.0000 152.400
129000 575000	202000 900000	0.63 1.07 1.59	98000 Series 98400	4.0000 101.600	0.14 3.5	5.04 128.0	98789D	7.8750 200.025	3.1581 80.216	0.09 2.3	7.40 188.0	4.5625 115.888
206000 920000	395000 1760000	0.41 1.66 2.47	99000 Series 99550	5.5000 139.700	0.28 7.0	6.69 170.0	99102D	10.0000 254.000	4.3750 111.125	0.06 1.5	9.37 238.0	5.8750 149.225
222000 985000	485000 2150000	0.35 1.91 2.85	127000 Series EE127095	9.5000 241.300	0.25 6.4	10.51 267.0	127139D	13.9960 355.498	4.0000 101.600	0.06 1.5	12.95 329.0	5.0000 127.000

* The maximum fillet on the shaft or in the housing that the bearing corner will clear.

† Any cone within a series may be used with a double cup of the same series.
Contact the NTN Application Engineering Department for possible changes in dimension W_N.

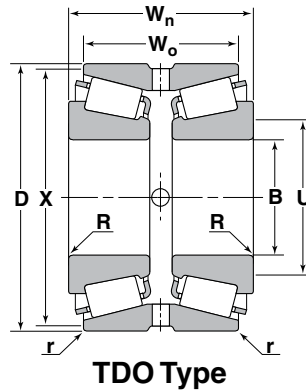

Basic Load Ratings		Axial Load Factors e Y ₁ Y ₂	Cone Number †	B	R	U	Cup Number	D	W ₀	r	X	W _n
Dynamic C _r	Static C _{0r}			Bore Diameter	Maximum Shaft Fillet Radius *	Minimum Shaft Shoulder Diameter		Outside Diameter	Cup Width	Maximum Housing Fillet Radius *	Maximum Housing Shoulder Diameter	Bearing Width Through Cones
lbs/N				Inch/mm					Inch/mm			
250000 1110000	770000 3450000	0.31 2.20 3.27	L163100 Series L163149	14.0000 355.600	0.14 3.5	14.72 374.0	L163110D	17.5000 444.500	4.3750 111.125	0.06 1.5	17.17 436.0	5.3750 136.524
211000 940000	345000 1540000	0.33 2.07 3.08	HH224300 Series HH224334	3.9360 99.974	0.14 3.5	4.88 124.0	HH224310D	8.3750 212.725	4.6250 117.475	0.06 1.5	7.94 202.0	5.6250 142.875
350000 1550000	825000 3650000	0.44 1.53 2.28	230000 Series EE231400	14.0000 355.600	0.25 6.4	15.28 388.0	231976D	19.7500 501.650	4.2500 107.950	0.06 1.5	19.41 493.0	6.1250 155.575
257000 1140000	470000 2100000	0.32 2.12 3.15	HM237500 Series HM237532	6.3120 160.325	0.28 7.0	7.56 192.0	HM237510D	11.3750 288.925	4.3750 111.125	0.06 1.5	10.68 271.0	5.6250 142.875
140000 625000	315000 1390000	0.32 2.12 3.15	LM241100 Series LM 241149	8.0000 203.200	0.14 3.5	8.62 219.0	LM241110D	10.8750 276.225	2.8750 73.025	0.03 0.8	10.51 267.0	3.5625 90.485
232000 1030000	530000 2350000	0.33 2.03 3.02	M244200 Series M244249	8.6875 220.662	0.25 6.4	9.65 245.0	M244210D	12.3750 314.325	4.1875 106.362	0.06 1.5	11.81 300.0	5.1875 131.762
180000 800000	365000 1620000	0.33 2.03 3.02	LM249700 Series LM249748	10.0000 254.000	0.14 3.5	10.71 272.0	LM249710D	13.6875 347.662	2.7500 69.850	0.06 1.5	13.11 333.0	3.7500 95.250
530000 2350000	1300000 5800000	0.33 2.02 3.00	HM261000 Series HM261049	13.1250 333.375	0.25 6.4	14.29 363.0	HM261010D	18.5000 469.900	6.0000 152.400	0.06 1.5	17.69 449.0	7.5000 190.500
200000 890000	515000 2280000	0.36 1.88 2.80	L357000 Series L357049	12.0000 304.800	0.25 6.4	12.95 329.0	L357010D	15.5000 393.700	3.2500 82.550	0.06 1.5	14.96 380.0	4.2500 107.950

* The maximum fillet on the shaft or in the housing that the bearing corner will clear.

† Any cone within a series may be used with a double cup of the same series.

Contact the NTN Application Engineering Department for possible changes in dimension W_n.

Basic Load Ratings		Axial Load Factors e Y ₁ Y ₂	Cone Number †	B	R	U	Cup Number	D	W _O	r	X	W _n
Dynamic C _r	Static C _{or}			Bore Diameter	Maximum Shaft Fillet Radius *	Minimum Shaft Shoulder Diameter		Outside Diameter	Cup Width	Maximum Housing Fillet Radius *	Maximum Housing Shoulder Diameter	Bearing Width Through Cones
lbs/N				Inch/mm				Inch/mm				
237000 1050000	585000 2600000	0.36 1.87 2.79	LM451300 Series LM451345	10.3750 263.525	0.14 3.5	11.14 283.0	LM451310D	14.0000 355.600	4.0000 101.600	0.06 1.5	13.50 343.0	5.0000 127.000
530000 2350000	1100000 4950000	0.39 1.73 2.57	526000 Series EE526130	13.0000 330.200	0.25 6.4	14.17 360.0	526191D	19.0000 482.600	5.0000 127.000	0.06 1.5	17.87 454.0	7.0000 177.800
255000 1130000	695000 3100000	0.43 1.56 2.33	LM654600 Series LM654649	11.2500 285.750	0.14 3.5	12.05 306.0	LM654610D	14.9960 380.898	4.2500 107.950	0.06 1.5	14.49 368.0	5.5000 139.700
157000 700000	263000 1170000	0.74 0.92 1.36	HM926700 Series HM926740	4.5000 114.300	0.14 3.5	5.75 146.0	HM926710D	9.0000 228.600	3.3125 84.138	0.09 2.3	8.54 217.0	4.5625 115.888
284000 1260000	770000 3400000	0.71 0.95 1.41	LM961500 Series LM961548	13.5000 342.900	0.13 3.3	14.45 367.0	LM961511D	17.9960 457.098	4.0000 101.600	0.06 1.5	17.44 443.0	5.6250 142.875

* The maximum fillet on the shaft or in the housing that the bearing corner will clear.

† Any cone within a series may be used with a double cup of the same series.

Contact the NTN Application Engineering Department for possible changes in dimension W_n.

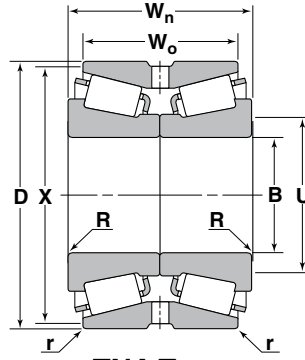

TNA Type

Basic Load Ratings		Axial Load Factors e Y_1 Y_2	Cone Number	B	R	U	Cup Number	D	W _o	r	X	W _n
Dynamic C_r	Static C_{or}			Bore Diameter	Maximum Shaft Fillet Radius *	Minimum Shaft Shoulder Diameter		Outside Diameter	Cup Width	Maximum Housing Fillet Radius *	Maximum Housing Shoulder Diameter	Bearing Width Through Cones
lbs/N				Inch/mm				Inch/mm				
31500 140000	48500 215000	0.40 1.68 2.50	395 Series NA397	2.3622 60.000	0.14 3.5	2.87 73.0	394D	4.3307 110.000	1.8125 46.038	0.03 0.8	4.11 104.0	2.0625 52.390
43000 190000	63500 283000	0.34 2.01 3.00	455 Series NA455	2.0000 50.800	0.14 3.5	2.56 65.0	452D	4.2500 107.950	2.1250 53.975	0.03 0.8	3.94 100.0	2.5626 65.090
45500 202000	72000 320000	0.38 1.75 2.61	475 Series NA482	2.7500 69.850	0.14 3.5	3.27 83.0	472D	4.7244 120.000	2.1250 53.975	0.03 0.8	4.49 114.0	2.5626 65.090
49000 218000	83500 370000	0.44 1.52 2.26	495 Series NA495A	3.0000 76.200	0.14 3.5	3.62 92.0	493D	5.3750 136.525	2.1250 53.975	0.03 0.8	5.12 130.0	2.7500 69.850
60000 268000	95500 425000	0.35 1.95 2.90	555 Series NA558	2.3750 60.325	0.14 3.5	2.99 76.0	552D	4.8750 123.825	2.5000 63.500	0.06 1.5	4.53 115.0	3.1250 79.375
62000 276000	101000 450000	0.36 1.85 2.76	565 Series NA569	2.6250 66.675	0.14 3.5	3.23 82.0	563D	5.0000 127.000	2.5625 65.088	0.06 1.5	4.69 119.0	3.1875 80.962
65500 291000	112000 500000	0.40 1.68 2.50	575 Series NA580	3.2500 82.550	0.14 3.5	3.86 98.0	572D	5.5115 139.992	2.6250 66.675	0.03 0.8	5.24 133.0	3.2500 82.550

* The maximum fillet on the shaft or in the housing that the bearing corner will clear.

Bore Diameter		Tolerance (Class 2)	
Inch/mm		.0001 Inch/micrometers	
Over	Inclusive	High	Low
0 0	3.0000 76.200	+ 5 + 13	0 0
3.0000 76.200	10.5000 266.700	+ 10 + 25	0 0

Outside Diameter		Tolerance (Class 2)	
Inch/mm		.0001 Inch/micrometers	
Over	Inclusive	High	Low
0 0	12.0000 304.800	+ 10 + 25	0 0
12.0000 304.800	24.0000 609.600	+ 20 + 51	0 0

Cone Number	B	Cup Number	D	Rotating Cone			Stationary Cup		Stationary Cone		Rotating Cup	
	Bore Diameter		Outside Diameter	Shaft Diameter	Resultant Fit	Housing Diameter	Resultant Fit	Shaft Diameter	Resultant Fit	Housing Diameter	Resultant Fit	
	Inch/mm		Inch/mm		.0001 Inch/micrometers	Inch/mm	.0001 Inch/micrometers	Inch/mm	.0001 Inch/micrometers	Inch/mm	.0001 Inch/micrometers	
395 Series NA397	2.3622	394D	4.3307	2.3642	20T	4.3327	10L	—	—	—	—	
	60.000		110.000	60.051	5T	110.051	30L	—	—	—	—	
				60.025	51T	110.076	25L	—	—	—	—	
455 Series NA455	2.0000	452D	4.2500	2.0020	20T	4.2520	10L	—	—	—	—	
	50.800		107.950	2.0010	5T	108.001	30L	—	—	—	—	
				50.851	51T	108.026	25L	—	—	—	—	
475 Series NA482	2.7500	472D	4.7244	2.7525	25T	4.7264	10L	—	—	—	—	
	69.850		120.000	2.7515	10T	120.051	30L	—	—	—	—	
				69.914	64T	120.076	25L	—	—	—	—	
495 Series NA495A	3.0000	493D	5.3750	3.0025	25T	5.3770	10L	—	—	—	—	
	76.200		136.525	3.0015	10T	136.576	30L	—	—	—	—	
				76.264	64T	136.601	25L	—	—	—	—	
555 Series NA558	2.3750	552D	4.8750	2.3770	20T	4.8770	10L	—	—	—	—	
	60.325		123.825	2.3760	5T	123.876	30L	—	—	—	—	
				60.376	51T	123.901	25L	—	—	—	—	
565 Series NA569	2.6250	563D	5.0000	2.6275	25T	5.0020	10L	—	—	—	—	
	66.675		127.000	2.6265	10T	127.051	30L	—	—	—	—	
				66.738	64T	127.076	25L	—	—	—	—	
575 Series NA580	3.2500	572D	5.5115	3.2525	25T	5.5135	10L	—	—	—	—	
	82.550		139.992	3.2515	5T	140.043	30L	—	—	—	—	
				82.614	64T	140.068	25L	—	—	—	—	
			82.588	13T		76L	—	—	—	—		

* The maximum fillet on the shaft or in the housing that the bearing corner will clear.

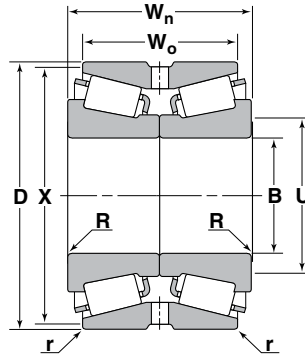

TNA Type

Basic Load Ratings		Axial Load Factors e Y_1 Y_2	Cone Number	B	R	U	Cup Number	D	W _o	r	X	W _n
Dynamic C_r	Static C_{or}			Bore Diameter	Maximum Shaft Fillet Radius *	Minimum Shaft Shoulder Diameter		Outside Diameter	Cup Width	Maximum Housing Fillet Radius *	Maximum Housing Shoulder Diameter	Bearing Width Through Cones
lbs/N				Inch/mm				Inch/mm				
68500 305000	123000 550000	0.44 1.53 2.27	595 Series NA593	3.5000 88.900	0.14 3.5	4.09 104.0	592D	6.0000 152.400	2.5000 63.500	0.03 0.8	5.67 144.0	3.2500 82.550
74500 330000	117000 520000	0.36 1.87 2.78	635 Series NA643	2.7500 69.850	0.14 3.5	3.39 86.0	632D	5.3750 136.525	3.0000 76.200	0.06 1.5	4.92 125.0	3.7500 95.250
85500 380000	153000 680000	0.47 1.44 2.14	675 Series NA691	4.0000 101.600	0.14 3.5	4.65 118.0	672D	6.6250 168.275	2.7500 69.850	0.03 0.8	6.30 160.0	3.6250 92.075
100000 445000	162000 720000	0.33 2.07 3.08	745 Series NA749	3.2500 82.550	0.14 3.5	3.90 99.0	742D	6.1250 155.575	3.3750 85.725	0.06 1.5	5.63 143.0	4.0000 101.600
104000 460000	172000 765000	0.34 1.98 2.95	755 Series NA759	3.5000 88.900	0.14 3.5	4.17 106.0	752D	6.3750 161.925	3.3750 85.725	0.06 1.5	5.91 150.0	4.1250 104.775
110000 485000	193000 855000	0.39 1.75 2.61	775 Series NA776 NA782	3.7500 95.250 4.1250 104.775	0.14 3.5 0.14 3.5	4.49 114.0 4.80 122.0	774D 774D	7.1250 180.975 7.1250 180.975	3.3750 85.725 3.3750 85.725	0.06 1.5 0.06 1.5	6.61 168.0 6.61 168.0	4.1250 104.775 4.1250 104.775

* The maximum fillet on the shaft or in the housing that the bearing corner will clear.

Bore Diameter		Tolerance (Class 2)	
Inch/mm		.0001 Inch/micrometers	
Over	Inclusive	High	Low
0	3.0000	+ 5	0
0	76.200	+ 13	0
3.0000	10.5000	+ 10	0
76.200	266.700	+ 25	0

Outside Diameter		Tolerance (Class 2)	
Inch/mm		.0001 Inch/micrometers	
Over	Inclusive	High	Low
0	12.0000	+ 10	0
0	304.800	+ 25	0
12.0000	24.0000	+ 20	0
304.800	609.600	+ 51	0

Cone Number	B		D	Rotating Cone			Stationary Cup		Stationary Cone		Rotating Cup	
	Bore Diameter	Cup Number		Outside Diameter	Shaft Diameter	Resultant Fit	Housing Diameter	Resultant Fit	Shaft Diameter	Resultant Fit	Housing Diameter	Resultant Fit
	Inch/mm			Inch/mm		.0001 Inch/micrometers	Inch/mm	.0001 Inch/micrometers	Inch/mm	.0001 Inch/micrometers	Inch/mm	.0001 Inch/micrometers
595 Series NA593	3.5000 88.900	592D	6.0000 152.400	3.5030	30T	6.0020	10L	3.5010	10T	5.9980	30T	
				3.5020	10T	6.0030	30L	3.5000	10L	5.9990	10T	
				88.976	76T	152.451	25L	88.925	25T	152.349	76T	
			88.951	25T	152.476	76L	88.900	25L	152.375	25T		
635 Series NA643	2.7500 69.850	632D	5.3750 136.525	2.7525	25T	5.3770	10L	2.7505	5T	5.3730	30T	
				2.7515	10T	5.3780	30L	2.7500	15L	5.3740	10T	
				69.913	64T	136.576	25L	69.863	13T	136.474	76T	
			69.888	25T	136.601	76L	68.580	13L	136.500	25T		
675 Series NA691	4.0000 101.600	672D	6.6250 168.275	4.0030	30T	6.6270	10L	4.0010	10T	6.6230	30T	
				4.0020	10T	6.6280	30L	4.0000	10L	6.6240	10T	
				101.676	76T	168.326	25L	101.625	25T	168.224	76T	
			101.651	25T	168.351	76L	101.600	25L	168.250	25T		
745 Series NA749	3.2500 82.550	742D	6.1250 155.575	3.2525	25T	6.1270	10L	—	—	—	—	
				3.2515	5T	6.1280	30L	—	—	—	—	
				82.614	64T	155.626	25L	—	—	—	—	
			82.588	13T	155.651	76L	—	—	—	—		
755 Series NA759	3.5000 88.900	752D	6.3750 161.925	3.5030	30T	6.3370	10L	3.5010	10T	6.3730	30T	
				3.5020	10T	6.3780	30L	3.5000	10L	6.3740	10T	
				88.976	76T	161.976	25L	88.925	25T	161.874	76T	
			88.951	25T	162.001	76L	88.900	25L	161.900	25T		
775 Series NA776	3.7500 95.250	774D	7.1250 180.975	3.7530	30T	7.1270	10L	3.7510	10T	7.1230	30T	
				3.7520	10T	7.1280	30L	3.7500	10L	7.1240	10T	
				95.326	76T	181.026	25L	95.275	25T	180.924	76T	
			95.301	25T	181.051	76L	95.250	25L	180.950	25T		
NA782	4.1250 104.775	774D	7.1250 180.975	4.1280	30T	7.1270	10L	4.1260	10T	7.1230	30T	
				4.1270	10T	7.1280	30L	4.1250	10L	7.1240	10T	
				104.851	76T	181.026	25L	104.800	25T	180.924	76T	
			104.826	25T	181.051	76L	104.775	25L	180.950	25T		

* The maximum fillet on the shaft or in the housing that the bearing corner will clear.

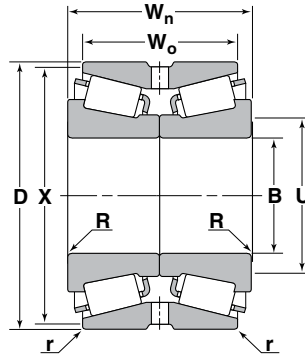

TNA Type

Basic Load Ratings		Axial Load Factors e Y_1 Y_2	Cone Number	B	R	U	Cup Number	D	W _o	r	X	W _n
Dynamic C_r	Static C_{or}			Bore Diameter	Maximum Shaft Fillet Radius *	Minimum Shaft Shoulder Diameter		Outside Diameter	Cup Width	Maximum Housing Fillet Radius *	Maximum Housing Shoulder Diameter	Bearing Width Through Cones
lbs/N				Inch/mm				Inch/mm				
120000 535000	232000 1030000	0.46 1.47 2.19	795 Series NA798	5.0000 127.000	0.14 3.5	5.71 145.0	792D	8.1250 206.375	3.2500 82.550	0.03 0.8	7.80 198.0	4.2500 107.950
147000 655000	250000 1110000	0.33 2.01 3.00	855 Series NA861	4.0000 101.600	0.14 3.5	4.65 118.0	854D	7.5000 190.500	4.0000 101.600	0.06 1.5	6.85 174.0	5.0000 127.000
178000 790000	300000 1340000	0.33 2.07 3.08	935 Series NA938	4.5000 114.300	0.14 3.5	5.28 134.0	932D	8.3750 212.725	4.6250 117.475	0.06 1.5	7.60 193.0	5.6250 142.875
97500 435000	249000 1110000	0.38 1.77 2.63	46700 Series NA46790	6.5000 165.100	0.14 3.5	7.13 181.0	46720D	8.8750 225.425	2.7500 69.850	0.03 0.8	8.58 218.0	3.7500 95.250
91000 405000	212000 945000	0.32 2.10 3.13	48300 Series NA48390	5.3750 136.525	0.14 3.5	5.94 151.0	48320D	7.5000 190.500	2.8750 73.025	0.03 0.8	7.24 184.0	3.3750 85.725
92000 410000	219000 975000	0.34 2.01 2.99	48600 Series NA48686	5.6250 142.875	0.14 3.5	6.22 158.0	48620D	7.8750 200.025	2.8750 73.025	0.03 0.8	7.60 193.0	3.6876 93.665
71500 320000	134000 595000	0.47 1.42 2.11	52000 Series NA52637D	3.7500 95.250	0.14 3.5	4.41 112.0	52637D	6.3750 161.925	2.4375 61.912	0.03 0.8	6.06 154.0	3.2499 82.547

* The maximum fillet on the shaft or in the housing that the bearing corner will clear.

Bore Diameter		Tolerance (Class 2)	
Inch/mm		.0001 Inch/micrometers	
Over	Inclusive	High	Low
0 0	3.0000 76.200	+ 5 + 13	0 0
3.0000 76.200	10.5000 266.700	+ 10 + 25	0 0

Outside Diameter		Tolerance (Class 2)	
Inch/mm		.0001 Inch/micrometers	
Over	Inclusive	High	Low
0 0	12.0000 304.800	+ 10 + 25	0 0
12.0000 304.800	24.0000 609.600	+ 20 + 51	0 0

Cone Number	B	Cup Number	D	Rotating Cone			Stationary Cup		Stationary Cone		Rotating Cup	
	Bore Diameter		Outside Diameter	Shaft Diameter	Resultant Fit	Housing Diameter	Resultant Fit	Shaft Diameter	Resultant Fit	Housing Diameter	Resultant Fit	
	Inch/mm		Inch/mm		.0001 Inch/micrometers	Inch/mm	.0001 Inch/micrometers	Inch/mm	.0001 Inch/micrometers	Inch/mm	.0001 Inch/micrometers	
795 Series NA798	5.0000 127.000	792D	8.1250 206.375	5.0035 127.089 5.0025 127.064	35T 15T 89T 38T	8.1270 8.1280 206.426 206.451	10L 30L 25L 76L	5.0010 5.0000 127.025 127.000	10T 10L 25T 25L	8.1230 8.1240 206.324 206.350	30T 10T 76T 25T	
855 Series NA861	4.0000 101.600	854D	7.5000 190.500	4.0030 4.0020 101.676 101.651	30T 10T 76T 25T	7.5020 7.5030 190.551 190.576	10L 30L 25L 76L	4.0010 4.0000 101.625 101.600	10T 10L 25T 25L	7.4980 7.4990 190.449 190.475	30T 10T 76T 25T	
935 Series NA938	4.5000 114.300	932D	8.3750 212.725	4.5035 4.5025 114.389 114.364	35T 15T 89T 38T	8.3770 8.3780 212.776 212.801	10L 30L 25L 76L	4.5010 4.5000 114.325 114.300	10T 10L 25T 25L	8.3730 8.3740 212.674 212.700	30T 10T 76T 25T	
46700 Series NA46790	6.5000 165.100	46720D	8.8750 225.425	6.5045 6.5035 165.214 165.189	45T 25T 114T 64T	8.8770 8.8780 225.476 225.501	10L 30L 25L 76L	— — — —	— — — —	— — — —	— — — —	
48300 Series NA48390	5.3750 136.525	48320D	7.5000 190.500	5.3785 5.3775 136.614 136.588	35T 15T 89T 38T	7.5020 7.5030 190.551 190.576	10L 30L 25L 76L	— — — —	— — — —	— — — —	— — — —	
48600 Series NA48686	5.6250 142.875	48620D	7.8750 200.025	5.6290 5.6280 142.977 142.951	40T 20T 102T 51T	7.8770 7.8780 200.076 200.101	10L 30L 25L 76L	— — — —	— — — —	— — — —	— — — —	
52000 Series NA52375	3.7500 95.250	52637D	6.3750 161.925	3.7530 3.7520 95.326 95.301	30T 10T 76T 25T	6.3770 6.3780 161.976 162.001	10L 30L 25L 76L	3.7510 3.7500 95.275 95.250	10T 10L 25T 25L	6.3730 6.3740 161.874 161.900	30T 10T 76T 25T	

* The maximum fillet on the shaft or in the housing that the bearing corner will clear.

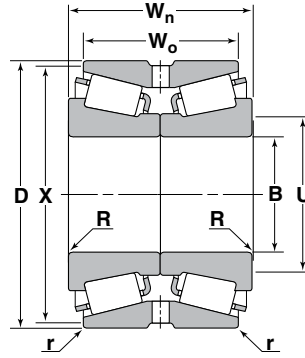

TNA Type

Basic Load Ratings		Axial Load Factors e Y_1 Y_2	Cone Number	B	R	U	Cup Number	D	W _o	r	X	W _n
Dynamic C_r	Static C_{or}			Bore Diameter	Maximum Shaft Fillet Radius *	Minimum Shaft Shoulder Diameter		Outside Diameter	Cup Width	Maximum Housing Fillet Radius *	Maximum Housing Shoulder Diameter	Bearing Width Through Cones
lbs/N				Inch/mm				Inch/mm				
130000 575000	305000 1350000	0.44 1.53 2.28	67700 Series NA67790	7.0000 177.800	0.14 3.5	7.64 194.0	67720D	9.7500 247.650	3.3125 84.138	0.03 0.8	9.45 240.0	4.0625 103.188
116000 515000	212000 945000	0.42 1.62 2.41	71000 Series NA71450	4.5000 114.300	0.14 3.5	5.20 132.0	71751D	7.5000 190.500	3.1875 80.962	0.06 1.5	7.13 181.0	4.1875 106.362
122000 545000	241000 1070000	0.49 1.38 2.06	74000 Series NA74525	5.2500 133.350	0.14 3.5	5.98 152.0	74851D	8.5000 215.900	3.1875 80.962	0.06 1.5	8.19 208.0	4.1875 106.362
127000 565000	228000 1010000	0.35 1.92 2.86	81000 Series NA81550 NA81600	5.5000 139.700 6.0000 152.400	0.14 3.5 0.14 3.5	5.98 152.0 6.50 165.0	81963D 81963D	9.6250 244.475 9.6250 244.475	3.1250 79.375 3.1250 79.375	0.06 1.5 0.06 1.5	9.21 234.0 9.21 234.0	4.2500 107.950 4.2500 107.950
167000 740000	325000 1440000	0.44 1.53 2.28	82000 Series NA82587	5.8750 149.225	0.14 3.5	6.73 171.0	82951D	9.5000 241.300	4.1875 106.362	0.06 1.5	8.90 226.0	5.1875 131.762
232000 1030000	500000 2230000	0.52 1.30 1.93	93000 Series NA93800	8.0000 203.200	0.22 5.5	9.06 230.0	93127D	12.5000 317.500	4.3750 111.125	0.06 1.5	11.81 300.0	5.7500 146.050

* The maximum fillet on the shaft or in the housing that the bearing corner will clear.

Bore Diameter		Tolerance (Class 2)	
Inch/mm		.0001 Inch/micrometers	
Over	Inclusive	High	Low
0 0	3.0000 76.200	+ 5 + 13	0 0
3.0000 76.200	10.5000 266.700	+ 10 + 25	0 0

Outside Diameter		Tolerance (Class 2)	
Inch/mm		.0001 Inch/micrometers	
Over	Inclusive	High	Low
0 0	12.0000 304.800	+ 10 + 25	0 0
12.0000 304.800	24.0000 609.600	+ 20 + 51	0 0

Cone Number	B		D	Rotating Cone			Stationary Cup		Stationary Cone		Rotating Cup							
	Bore Diameter	Cup Number		Outside Diameter	Shaft Diameter	Resultant Fit	Housing Diameter	Resultant Fit	Shaft Diameter	Resultant Fit	Housing Diameter	Resultant Fit						
	Inch/mm			Inch/mm		.0001 Inch/micrometers	Inch/mm	.0001 Inch/micrometers	Inch/mm	.0001 Inch/micrometers	Inch/mm	.0001 Inch/micrometers						
67700 Series NA67790	7.0000	67720D	9.7500	7.0045	45T	9.7520	10L	—	—	—	—							
	177.800			7.0035								25T	9.7530	30L	—	—		
				114T								247.701	25L	—	—			
			247.650	177.914	64T	247.726	76L	—	—	—	—							
71000 Series NA71450	4.5000	71751D	7.5000	4.5035	35T	7.5020	10L	4.5010	10T	7.4980	30T							
	114.300			4.5025								15T	7.5030	30L	4.5000	10L	7.4990	10T
				114.389								89T	190.551	25L	114.325	25T	190.449	76T
			190.500	114.364	38T	190.576	76L	114.300	25L	190.475	25T							
74000 Series NA74585	5.2500	74851D	8.5000	5.2535	35T	8.5020	10L	—	—	—	—							
	133.3501			5.2525								15T	8.5030	30L	—	—		
				133.439								89T	215.951	25L	—	—		
			215.900	133.414	38T	215.976	76L	—	—	—	—							
81000 Series NA81550	5.5000	81963D	9.6250	5.5040	40T	9.6270	10L	—	—	—	—							
	139.700			5.5030								20T	9.6280	30L	—	—		
				139.802								102T	244.526	25L	—	—		
			244.475	139.776	51T	244.551	76L	—	—	—	—							
NA81600	6.0000	81963D	9.6250	6.0040	40T	9.6270	10L	—	—	—	—							
	152.400			6.0030								20T	9.6280	30L	—	—		
				6.0030								102T	244.526	25L	—	—		
			244.475	152.502	51T	244.511	76L	—	—	—	—							
82000 Series NA82587	5.8750	82951D	9.5000	5.8790	40T	9.5020	10L	—	—	—	—							
	149.225			5.8780								20T	9.5030	30L	—	—		
				149.327								102T	241.351	25L	—	—		
			241.300	149.301	51T	241.376	76L	—	—	—	—							
93000 Series NA93800	8.0000	93127D	12.5000	8.0050	50T	12.5040	20L	—	—	—	—							
	203.200			8.0040								30T	12.5060	60L	—	—		
				203.327								127T	317.602	51L	—	—		
			317.500	203.302	76T	317.652	152L	—	—	—	—							

* The maximum fillet on the shaft or in the housing that the bearing corner will clear.

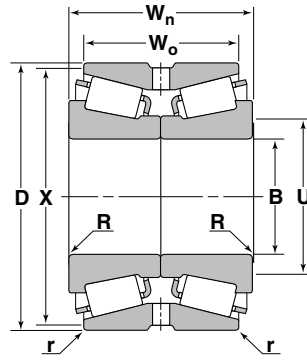

TNA Type

Basic Load Ratings		Axial Load Factors e Y ₁ Y ₂	Cone Number	B	R	U	Cup Number	D	W _o	r	X	W _n
Dynamic C _r	Static C _{or}			Bore Diameter	Maximum Shaft Fillet Radius *	Minimum Shaft Shoulder Diameter		Outside Diameter	Cup Width	Maximum Housing Fillet Radius *	Maximum Housing Shoulder Diameter	Bearing Width Through Cones
lbs/N				Inch/mm				Inch/mm				
207000 920000	415000 1850000	0.47 1.44 2.14	94000 Series									
			NA94650	6.5000 165.100	0.14 3.5	7.32 186.0	94114D	11.3750 288.925	4.3750 111.125	0.06 1.5	10.71 272.0	5.6250 142.875
			NA94700	7.0000 177.800	0.22 5.5	7.99 203.0	94114D	11.3750 288.925	4.3750 111.125	0.06 1.5	10.71 272.0	5.6250 142.875
196000 875000	355000 1590000	0.37 1.82 2.71	95000 Series									
			NA95500	5.0000 127.000	0.14 3.5	5.87 149.0	95927D	9.2500 234.950	4.5000 114.300	0.06 1.5	8.54 217.0	5.6250 142.875
206000 920000	395000 1760000	0.41 1.65 2.46	99000 Series									
			NA99600	6.0000 152.400	0.14 3.5	6.85 174.0	99102D	10.0000 254.000	4.3750 111.125	0.06 1.5	9.37 128.0	5.6250 142.875
166000 740000	265000 1180000	0.33 2.02 3.00	HH221400 Series									
			HH221449NA	4.0000 101.600	0.31 8.0	5.16 131.0	HH2214100	7.5000 190.500	4.1250 104.775	0.06 1.5	7.05 179.0	5.0000 127.000
211000 940000	345000 1540000	0.33 2.07 3.08	HH224300 Series									
			HH224346NA	4.5000 114.300	0.14 3.5	5.35 136.0	HH224310D	8.3750 212.725	4.6250 117.475	0.06 1.5	7.94 202.0	5.6250 142.875
257000 1140000	470000 2100000	0.32 2.12 3.15	HM237500 Series									
			HM237536NA	6.5000 165.100	0.14 3.5	7.28 185.0	HM237510D	11.3750 288.925	4.3750 111.125	0.06 1.5	10.68 271.0	5.6250 142.875
			HM237545NA	7.0000 177.800	0.22 5.5	7.95 202.0	HM237510D	11.3750 288.925	4.3750 111.125	0.06 1.5	10.68 271.0	5.6250 142.875

* The maximum fillet on the shaft or in the housing that the bearing corner will clear.

Bore Diameter		Tolerance (Class 2)	
Inch/mm		.0001 Inch/micrometers	
Over	Inclusive	High	Low
0 0	3.0000 76.200	+ 5 + 13	0 0
3.0000 76.200	10.5000 266.700	+ 10 + 25	0 0

Outside Diameter		Tolerance (Class 2)	
Inch/mm		.0001 Inch/micrometers	
Over	Inclusive	High	Low
0 0	12.0000 304.800	+ 10 + 25	0 0
12.0000 304.800	24.0000 609.600	+ 20 + 51	0 0

Cone Number	B	Cup Number	D	Rotating Cone			Stationary Cup		Stationary Cone		Rotating Cup	
	Bore Diameter		Outside Diameter	Shaft Diameter	Resultant Fit	Housing Diameter	Resultant Fit	Shaft Diameter	Resultant Fit	Housing Diameter	Resultant Fit	
	Inch/mm		Inch/mm		.0001 Inch/micrometers	Inch/mm	.0001 Inch/micrometers	Inch/mm	.0001 Inch/micrometers	Inch/mm	.0001 Inch/micrometers	
94000 Series NA94650	6.5000	94114D	11.3750	6.5045 6.5035	45T 25T	11.3770 11.3780	10L 30L	— —	— —	— —	— —	
	165.100		288.925	165.214 165.189	114T 64T	288.976 289.001	25L 76L	— —	— —	— —	— —	
NA94700	7.0000	94114D	11.3750	7.0045 7.0035	45T 25T	11.3770 11.3780	10L 30L	— —	— —	— —	— —	
	177.800		288.925	177.914 177.889	114T 64T	288.976 289.001	25L 76L	— —	— —	— —	— —	
95000 Series NA95500	5.0000	99102D	9.2500	5.0035 5.0025	35T 15T	9.2520 9.2530	10L 30L	5.0010 5.0000	10T 10L	9.2480 9.2490	30T 10T	
	127.000		234.950	127.089 127.064	89T 38T	235.001 235.026	25L 76L	127.025 127.000	25T 25L	234.899 234.925	76T 25T	
99000 Series NA99600	6.0000	99102D	10.0000	6.0040 6.0030	40T 20T	10.0020 10.0030	10L 30L	— —	— —	— —	— —	
	152.400		254.000	152.502 152.476	102T 51T	254.051 254.076	25L 76L	— —	— —	— —	— —	
HH221400 Series HH221449NA	4.0000	HH221410D	7.5000	4.0030 4.0020	30T 10T	7.5020 7.5030	10L 30L	4.0010 4.0000	10T 10L	7.4980 7.4990	30T 10T	
	101.600		190.500	101.676 101.651	76T 25T	190.551 190.576	25L 76L	101.625 101.600	25T 25L	190.449 190.475	76T 25T	
HH224300 Series HH224346N	4.5000	HH224310D	8.3750	4.5035 4.5025	35T 15T	8.3770 8.3780	10L 30L	4.5010 4.5000	10T 10L	8.3730 8.3740	30T 10T	
	114.300		212.725	114.389 114.364	89T 38T	212.776 212.801	25L 76L	114.325 114.300	25T 25L	212.674 212.700	76T 25T	
HM237500 Series HM237536	6.5000	HM237510D	11.3750	6.5045 6.5035	45T 25T	11.3770 11.3780	10L 30L	— —	— —	— —	— —	
	165.100		288.925	165.214 165.189	114T 64T	288.976 289.001	25L 76L	— —	— —	— —	— —	
HM237545	7.0000	HM237510D	11.3750	7.0045 7.0035	45T 25T	11.3770 11.3780	10L 30L	— —	— —	— —	— —	
	177.800		288.925	177.914 177.889	114T 64T	288.976 289.001	25L 76L	— —	— —	— —	— —	

* The maximum fillet on the shaft or in the housing that the bearing corner will clear.

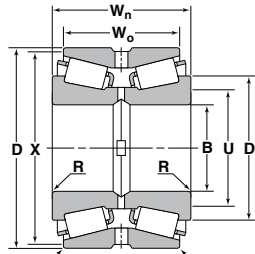

TNASWE Type

Cone large flange diameter (D₁) is ground for sealing purposes.

Basic Load Ratings		Axial Load Factors e Y ₁ Y ₂	Cone Number	B	R	U	D ₁	Cup Number	D	W ₀	r	X	W _n
Dynamic C _r	Static C _{0r}			Bore Diameter	Maximum Shaft Fillet Radius *	Minimum Shaft Shoulder Diameter	Nominal Large Flange Diameter		Outside Diameter	Cup Width	Maximum Housing Fillet Radius *	Maximum Housing Shoulder Diameter	Bearing Width Through Cones
lbs/N				Inch/mm					Inch/mm				
45500 202000	72000 320000	0.38 1.75 2.61	475 Series NA483SW	2.7559 70.000	0.14 3.5	3.07 78.0	3.6540 92.8100	472D	4.7244 120.000	2.1250 53.975	0.03 0.8	5.12 130.0	2.7500 69.850
65500 291000	112000 500000	0.40 1.67 2.49	575 Series NA580SW	3.2500 82.550	0.14 3.5	3.86 98.0	4.3229 109.8020	572D	5.5115 139.992	2.6250 66.675	0.03 0.8	5.24 133.0	3.2500 82.550
179000 795000	415000 1850000	0.41 1.67 2.48	8500 Series NA8575SW	9.2500 234.950	0.25 6.4	10.20 259.0	11.006 279.55	8520D	12.8750 327.025	3.2500 82.550	0.06 1.5	12.32 313.0	4.6250 117.475
97500 435000	249000 1110000	0.38 1.77 2.63	46700 Series NA46790SW	6.5000 165.100	0.14 3.5	7.13 181.0	7.760 197.10	46720D	8.8750 225.425	2.7500 69.850	0.03 0.8	8.58 218.0	3.7500 95.250
86000 385000	194000 865000	0.31 2.22 3.30	48200 Series NA48290SW	5.0000 127.000	0.14 3.5	5.55 141.0	6.110 155.19	48220D	7.1875 182.562	2.8750 73.025	0.03 0.8	6.93 176.0	3.6874 93.660
92000 410000	219000 975000	0.34 2.00 2.98	48600 Series NA48685SW	5.6250 142.875	0.14 3.5	6.22 158.0	6.775 172.08	48620D	7.8750 200.025	2.8750 73.025	0.03 0.8	7.60 193.0	3.6876 93.665
73000 325000	139000 620000	0.50 1.36 2.03	56000 Series NA56425SW	4.2500 107.950	0.14 3.5	4.84 123.0	5.428 137.87	56650D	6.5000 165.100	2.5000 63.500	0.03 0.8	6.26 159.0	3.5000 88.900
140000 625000	315000 1390000	0.32 2.12 3.15	LM241100 Series LM241149NW	8.0000 203.200	0.14 3.5	8.66 220.0	9.466 240.44	LM241110D	10.8750 276.225	2.8750 73.025	0.03 0.8	10.51 267.0	3.7500 95.250
180000 800000	365000 1620000	0.33 2.03 3.02	LM249700 Series LM249747NW	9.9990 253.975	0.14 3.5	10.71 272.0	11.586 294.28	LM249710D	13.6875 347.662	2.7500 69.850	0.06 1.5	13.11 333.0	4.0000 101.600
193000 860000	465000 2070000	0.32 2.12 3.15	LM251600 Series LM251649NW	10.5000 266.700	0.25 6.4	11.61 295.0	12.204 309.98	LM251610D	13.8750 352.425	3.2500 82.550	0.06 1.5	13.54 344.0	4.2500 107.950
200000 890000	515000 2280000	0.36 1.88 2.80	L357000 Series L357049NW	12.0000 304.800	0.25 6.4	12.95 329.0	13.797 350.44	L357010D	15.5000 393.700	3.2500 82.550	0.06 1.5	14.96 380.0	4.2500 107.950

* The maximum fillet on the shaft or in the housing that the bearing corner will clear.

Bore Diameter		Tolerance (Class 2)	
Inch/mm		.0001 Inch/micrometers	
Over	Inclusive	High	Low
0 0	3.0000 76.200	+ 5 + 13	0 0
3.0000 76.200	10.5000 266.700	+ 10 + 25	0 0

Outside Diameter		Tolerance (Class 2)	
Inch/mm		.0001 Inch/micrometers	
Over	Inclusive	High	Low
0 0	12.0000 304.800	+ 10 + 25	0 0
12.0000 304.800	24.0000 609.600	+ 20 + 51	0 0

Cone Number	B	Cup Number	D	Stationary Cone			Rotating Cup (Clamped Design)		Stationary Cone		Rotating Cup (Floating Design)	
	Bore Diameter		Outside Diameter	Shaft Diameter	Resultant Fit	Housing Diameter	Resultant Fit	Shaft Diameter	Resultant Fit	Housing Diameter	Resultant Fit	
	Inch/mm		Inch/mm	Inch/mm	.0001 Inch/micrometers	Inch/mm	.0001 Inch/micrometers	Inch/mm	.0001 Inch/micrometers	Inch/mm	.0001 Inch/micrometers	
475 Series NA483SW	2.7559	472D	4.7244	2.7559 2.7549	0L 15L	4.7234 4.7224	30T 10T	2.7559 2.7549	0L 15L	4.7224 4.7214	40T 20T	
	70.000		120.00	70.000 69.974	0L 38L	119.974 119.949	76T 25T	70.000 69.974	0L 38L	119.949 119.924	102T 51T	
575 Series NA580SW	3.2500	572D	5.5115	3.2500 3.2485	0L 25L	5.5105 5.5095	30T 10T	3.2500 3.2485	0L 25L	5.5095 5.5085	40T 20T	
	82.550		139.992	82.550 82.512	0L 63L	139.967 139.941	76T 25T	82.550 82.512	0L 63L	139.941 139.916	102T 51T	
8500 Series NA8575SW	9.2500	8520D	12.8750	9.2500 9.2490	0L 25L	12.8720 12.8740	50T 10T	9.2500 9.2490	0L 25L	12.8710 12.8730	60T 20T	
	234.950		327.025	234.950 234.925	0L 63L	326.949 327.000	127T 25T	234.950 234.925	0L 63L	326.923 326.974	152T 51T	
46700 Series NA46790SW	6.5000	46720D	8.8750	6.5000 6.4990	0L 25L	8.8740 8.8730	30T 10T	6.5000 6.4990	0L 25L	8.8720 8.8730	40T 20T	
	165.100		225.425	165.100 165.075	0L 63L	225.374 225.400	76T 25T	165.100 165.075	0L 63L	225.349 225.374	102T 51T	
48200 Series NA48290SW	5.0000	48220D	7.1875	5.0000 4.9990	0L 25L	7.1855 7.1865	30T 10T	5.0000 4.9990	0L 25L	7.1845 7.1855	40T 20T	
	127.000		182.562	127.000 126.975	0L 63L	182.512 182.537	76T 25T	127.000 126.975	0L 63L	182.486 182.512	102T 51T	
48600 Series NA48685SW	5.6250	48620D	7.8750	5.6250 5.6240	0L 25L	7.8730 7.8740	30T 10T	5.6250 5.6240	0L 25L	7.8720 7.8730	40T 20T	
	142.875		200.025	142.875 142.850	0L 63L	199.974 200.000	76T 25T	142.875 142.850	0L 63L	199.949 199.974	102T 51T	
56000 Series NA56425SW	4.2500	56650D	6.5000	4.2500 4.2490	0L 25L	6.4980 6.4990	30T 10T	4.2500 4.2490	0L 25L	6.4970 6.4980	40T 20T	
	107.950		165.100	107.950 107.925	0L 63L	165.049 165.075	76T 25T	107.950 107.925	0L 63L	165.024 165.049	102T 51T	
LM241100 Series LM241149NW	8.0000	LM241110D	10.8750	8.0000 7.9990	0L 25L	10.8730 10.8740	30T 10T	8.0000 7.9990	0L 25L	10.8720 10.8730	40T 20T	
	203.200		276.225	203.200 203.175	0L 63L	276.174 276.200	76T 25T	203.200 203.175	0L 63L	276.149 276.174	102T 51T	
LM249700 Series LM249747NW	9.9990	LM249710D	13.6875	9.9990 9.9980	0L 25L	13.6845 13.6865	50T 10T	9.9990 9.9980	0L 25L	13.6835 13.6855	60T 20T	
	253.975		347.662	253.975 253.949	0L 63L	347.586 347.637	127T 25T	253.975 253.949	0L 63L	347.561 347.612	152T 51T	
LM251600 Series LM251649NW	10.5000	LM251610D	13.8750	10.5000 10.4985	0L 25L	13.8740 13.8720	50T 10T	10.5000 10.4985	0L 25L	13.8730 13.8710	60T 20T	
	266.700		352.425	266.700 266.662	0L 63L	352.400 352.349	127T 25T	266.700 266.662	0L 63L	352.374 352.324	152T 51T	
L357000 Series L357049NW	12.0000	L357010D	15.5000	12.0000 11.9990	0L 25L	15.4970 15.4990	50T 10T	12.0000 11.9990	0L 25L	15.4960 15.4980	60T 20T	
	304.800		393.700	304.800 304.775	0L 63L	393.624 393.675	127T 25T	304.800 304.775	0L 63L	393.598 393.649	152T 51T	

* The maximum fillet on the shaft or in the housing that the bearing corner will clear.

Tapered Roller Bearing Tolerance Tables

Tolerances for Inch System Bearings Class 4 and Class 2

Bearing Types	Bore Diameter Tolerance				Cone Width Tolerance				Cone Stand Tolerance				Cup Stand Tolerance				
	B				Wi				Wni				Wno				
	TS		TNA		TDI		TS		TNA		TDI		TS		TS		
	TSF		TNASW*		TDO		TSF		TNASW		TDO		TSF		TSF▲		
Bore Diameter		Class 4		Class 2		Class 4		Class 2		Class 4		Class 2		Class 4		Class 2	
Inch/mm		.0001 Inch/Micrometers															
Over	Incl	High	Low	High	Low	High	Low	High	Low	High	Low	High	Low	High	Low	High	Low
0.0000	3.0000	+5	0	+5	0	+30	-100	+30	-100	+40	0	+40	0	+40	0	+40	0
0.000	76.200	+13	0	+13	0	+76	-254	+76	-254	+102	0	+102	0	+102	0	+102	0
3.0000	4.0000	+10	0	+10	0	+30	-100	+30	-100	+40	0	+40	0	+40	0	+40	0
76.200	101.600	+25	0	+25	0	+76	-254	+76	-254	+102	0	+102	0	+102	0	+102	0
4.0000	12.0000	+10	0	+10	0	+30	-100	+30	-100	+60	-60	+40	0	+80	-40	+40	0
101.600	304.800	+25	0	+25	0	+76	-254	+76	-254	+152	-152	+102	0	+203	-102	+102	0
12.0000	24.0000	+20	0	+20	0	+30	-100	+30	-100	+70	-70	+70	-70	+80	-80	+80	-80
304.800	609.600	+51	0	+51	0	+76	-254	+76	-254	+178	-178	+178	-178	+203	-203	+203	-203
24.0000	36.0000	+30	0	—	—	+30	-100	—	—	+70	-70	—	—	+80	-80	—	—
609.600	914.400	+76	0	—	—	+76	-254	—	—	+178	-178	—	—	+203	-203	—	—
36.0000	48.0000	+40	0	—	—	+30	-100	—	—	+70	-70	—	—	+80	-80	—	—
914.400	1219.200	+51	0	—	—	+76	-254	—	—	+178	-178	—	—	+203	-203	—	—
48.0000	—	+50	0	—	—	+30	-100	—	—	+70	-70	—	—	+80	-80	—	—
1219.200	—	+127	0	—	—	+76	-254	—	—	+178	-178	—	—	+203	-203	—	—

* For TNASW type bearings, see tolerance tables located on page 197.

▲ For TSF type bearings, the cup stand is measured from the backface of the flange

Tolerances for Inch System Bearings Class 4 and Class 2

Bearing Types	Outside Diameter Tol				Cup Width Tolerance				Cup Flange Diameter Tol				Assembled Radial Runout				
	D				Wo				Df				Wno				
	TS		TNA		TDI		TS		TNA		TDI		TS		TNA		
	TSF		TNASW		TDO		TSF		TNASW		TDO		TSF		TNASW		
Outside Diameter		Class 4		Class 2		Class 4		Class 2		Class 4		Class 2		Class 4		Class 2	
Inch/mm		.0001 Inch/Micrometers															
Over	Incl	High	Low	High	Low	High	Low	High	Low	High	Low	High	Low	Maximum	Maximum		
0.0000	12.0000	+10	0	+10	0	+20	-100	+20	-100	+20	0	+20	0	20	15		
0.000	304.800	+25	0	+25	0	+51	-254	+51	-254	+51	0	+51	0	51	38		
12.0000	24.0000	+20	0	+20	0	+20	-100	+20	-100	+30	0	+30	0	20	15		
304.800	609.600	+51	0	+51	0	+51	-254	+51	-254	+76	0	+76	0	51	38		
24.0000	36.0000	+30	0	+30	0	+20	-100	+20	-100	+40	0	+40	0	30	20		
609.600	914.400	+76	0	+76	0	+51	-254	+51	-254	+102	0	+102	0	76	51		
36.0000	48.0000	+40	0	—	—	+20	-100	—	—	+50	0	—	—	30	—		
914.400	1219.200	+102	0	—	—	+51	-254	—	—	+127	0	—	—	76	—		
48.0000	—	+50	0	—	—	+20	-100	—	—	+50	0	—	—	30	—		
1219.200	—	+127	0	—	—	+51	-254	—	—	+127	0	—	—	76	—		

Tolerances for Inch System Bearings Class 4 and Class 2

Bearing Types	Overall Bearing Width Tolerance																
	TS				TNA				TDI				TQI				
	TSF■		TNASW		TDO		TQO		TS		TNA		TDI		TQI		
	TSF		TNASW		TDO		TQO		TSF		TNASW		TDO		TQO		
Bore Diameter		Class 4		Class 2		Class 4		Class 2		Class 4		Class 2		Class 4		Class 2	
Inch/mm		.0001 Inch/Micrometers															
Over	Incl	High	Low	High	Low	High	Low	High	Low	High	Low	High	Low	High	Low	High	Low
0.0000	4.0000	+80	0	+80	0	+100	0	+100	0	+160	0	+160	0	+600	-600	+600	-600
0.000	101.600	+203	0	+203	0	+254	0	+254	0	+406	0	+406	0	+1524	-1524	+1524	-1524
4.0000	5.0000	+140	-100	+80	0	+100	0	+100	0	+280	-200	+160	-80	+600	-600	+600	-600
101.600	127.000	+356	-254	+203	0	+254	0	+254	0	+711	-508	+406	-203	+1524	-1524	+1524	-1524
5.0000	12.0000	+140	-100	+80	0	+300	0	+280	0	+280	-200	+160	-80	+600	-600	+600	-600
127.000	304.800	+356	-254	+203	0	+76	-254	+76	-254	+711	-508	+406	-203	+1524	-1524	+1524	-1524
12.0000	24.0000	+150	-150	+150	-150	+30	-100	+30	-100	+300	-300	+300	-300	+600	-600	+600	-600
304.800	609.600	+381	-381	+381	-381	+76	-254	+76	-254	+762	-762	+762	-762	+1524	-1524	+1524	-1524
24.0000	—	+150	-150	—	—	+30	-100	—	—	+300	-300	—	—	+600	-600	+600	-600
609.600	—	+381	-381	—	—	+76	-254	—	—	+762	-762	—	—	+1524	-1524	+1524	-1524

■ For TSF type bearings, the tolerance is applied to the dimension from the backface of the flange to the backface of the cone.

**Tolerances for Metric System Bearings Class K and Class N
(For “J” Prefix Bearings)**

Bearing Types		Bore Diameter Tolerance				Cone Width Tolerance				Cone Stand Tolerance				Cup Stand Tolerance				Overall Brg Width Tolerance			
		TS		TSF		TS		TSF		TS		TSF		TS		TSF▲		TS		TSF■	
Bore Diameter		Class K		Class N		Class K		Class N		Class K		Class N		Class K		Class N		Class K		Class N	
Inch/mm		.0001 Inch/Micrometers																			
Over	Inclusive	High	Low	High	Low	High	Low	High	Low	High	Low	High	Low	High	Low	High	Low	High	Low	High	Low
0.7087 18.000	1.9685 50.000	0	-5	0	-5	0	-39	0	-20	+39	0	+20	0	+39	0	+20	0	+79	0	+39	0
1.9685 50.000	3.1496 80.000	0	-6	0	-6	0	-59	0	-20	+39	0	+20	0	+39	0	+20	0	+79	0	+39	0
3.1496 80.000	4.7244 120.000	0	-8	0	-8	0	-59	0	-20	+39	-39	+20	0	+39	-39	+20	0	+79	-79	+39	0
4.7244 120.000	7.0866 180.000	0	-10	0	-10	0	-79	0	-20	+59	-59	+20	0	+79	-39	+39	0	+138	-98	+59	0
7.0866 180.000	9.8425 250.000	0	-12	0	-12	0	-79	0	-20	+59	-59	+20	0	+79	-39	+39	0	+138	-98	+59	0

- ▲ For TSF type bearings, the cup stand is measured from the backface of the flange.
- For TSF type bearings, the tolerance is applied to the dimension from the backface of the flange to the backface of the cone.

**Tolerances for Metric System Bearings Class K and Class N
(For “J” Prefix Bearings)**

Bearing Types		Outside Diameter Tolerance				Cup Width Tolerance				Cup Flange Diameter Tolerance				Assembled Bearing Radial Runout	
		TS		TSF		TS		TSF		TSF		TS			
Outside Diameter		Class K		Class N		Class K		Class N		Class K		Class N		Class K	Class N
Inch/mm		.0001 Inch/Micrometers													
Over	Incl	High	Low	High	Low	High	Low	High	Low	High	Low	High	Low	Maximum	Maximum
3.1496 80.000	4.7244 120.000	0	-7	0	-7	0	-79	0	-39	0	-18	0	-18	14	14
4.7244 120.000	5.9055 150.000	0	-8	0	-8	0	-79	0	-39	0	-20	0	-20	16	16
5.9055 150.000	7.0866 180.000	0	-10	0	-10	0	-79	0	-39	0	-20	0	-20	18	18
7.0866 180.000	9.8425 250.000	0	-12	0	-12	0	-98	0	-39	0	-22	0	-22	20	20
9.8425 250.000	12.4016 315.000	0	-14	0	-14	0	-98	0	-39	0	-26	0	-26	24	24

Tapered Roller Bearing Fitting Practice Tables

The fitting practice data given in the following tables conforms to industry and ABMA/ANSI standards. These tables apply to solid or heavy-sectioned steel shafts, heavy-sectioned ferrous housings and normal operating conditions. Certain fitting practice data given in these tables may not be adequate for applications involving very heavy loads, very high speeds, unusual thermal conditions, light shafts and housing sections. In certain cases the method of assembly and the means and ease of obtaining the bearing setting may require

fits different from those given in the tables.

Fitting practice for nonadjustable TNA and TNASW two row bearings are shown on pages 184 to 195. Shaft and housing material, geometry, hardness and surface finish must be carefully controlled. Ground shafts should be finished to 50 micro-inches AA or better, for turned shafts a finish of 100 micro-inches AA or better, and housing bores should be finished to 160 micro-inches AA or better.

Cone Fitting Practice for Inch System Bearings Class 4 and Class 2

Bore Diameter			Rotating Cone		Rotating or Stationary Cone		Stationary Cone								
			Ground Shaft		Ground Shaft or Unground Shaft		Unground Shaft		Ground Shaft		Unground Shaft		Hardened and Ground Shaft		
			Steady Load with Moderate Shock		Heavy Loads, High Speed, or Shock		Moderate Loads, No Shock		Moderate Loads, No Shock		Sheaves, Wheels, Idlers		Wheel Spindles		
Inch/mm			.0001 Inch/Micrometers												
Over	Incl	Tolerance	Shaft Diameter	Resultant Fit	Shaft Diameter	Resultant Fit	Shaft Diameter	Resultant Fit	Shaft Diameter	Resultant Fit	Shaft Diameter	Resultant Fit	Shaft Diameter	Resultant Fit	
0.0	3.0000	+ 5 0	+ 10 5T + 15 15T	5T	+ 15 25T	10T	25T	0 + 5 5T	5L 5T	- 5 0 10L	10L 0 0	- 5 0 10L	10L 0 0	- 7 - 2 12L	12L 2L
0.0	76.200	+ 13 0	+ 25 12T + 38 38T	12T	+ 38 64T	25T	64T	0 + 13 13T	13L 13T	- 13 0 26L	26L 0 0	- 13 0 26L	26L 0 0	- 18 - 5 31L	31L 5L
3.0000	12.0000	+ 10 0	+ 15 25T + 25 13T	5T	25T	See Note		0 + 10 10T	10L 10T	- 10 0 20L	20L 0 0	- 10 0 20L	20L 0 0	- 12 - 2 22L	22L 2L
76.200	304.800	+ 25 0	+ 38 64T	13T	64T	See Note		0 + 25 25T	25L 25T	- 25 0 50L	50L 0 0	- 25 0 50L	50L 0 0	- 30 - 5 55L	55L 5L
12.0000	16.0000	+ 20 0	+ 30 50T + 50 25T	10T	50T	See Note		0 + 20 20T	20L 20T	- 20 0 40L	40L 0 0	- 20 0 40L	40L 0 0	— — —	— — —
304.800	406.400	+ 51 0	+ 76 127T	25T	127T	See Note		0 + 51 51T	51L 51T	- 51 0 102L	102L 0 0	- 51 0 102L	102L 0 0	— — —	— — —

NOTE: It is recommended that all shafts be ground. In those cases where this is not possible, a minimum shaft diameter should be provided equal to the Bore Diameter plus .0005 In/In (0.0005 mm/mm) of Bore Diameter. Add this value to the Bore Diameter tolerance.

Cup Fitting Practice for Inch System Bearings Class 4 and Class 2

Outside Diameter			Stationary Cup				Stationary or Rotating Cup		Rotating Cup	
			Clamped or Floating		Adjustable		Nonadjustable or Sheaves—Clamped		Sheaves—Unclamped	
Inch/mm			.0001 Inch/Micrometers							
Over	Incl	Tolerance	Housing Diameter	Resultant Fit	Housing Diameter	Resultant Fit	Housing Diameter	Resultant Fit	Housing Diameter	Resultant Fit
0.0	3.0000	+ 10 0	+ 20 30L	10L	0 + 10	10T 10L	- 15 - 5	25T 5T	- 30 - 20	40T 20T
0.0	76.200	+ 25 0	+ 51 76L	26L	0 + 25	25T 25L	- 38 - 13	63T 13T	- 76 - 31	101T 51T
3.0000	5.0000	+ 10 0	+ 20 30L	10L	0 + 10	10T 10L	- 20 - 10	30T 10T	- 30 - 20	40T 20T
76.200	127.000	+ 25 0	+ 51 76L	26L	0 + 25	25T 25L	- 51 - 25	76T 25T	- 76 - 51	101T 51T
5.0000	12.0000	+ 10 0	+ 20 30L	10L	0 + 20	10T 20L	- 20 - 10	30T 10T	- 30 - 20	40T 20T
127.000	304.800	+ 25 0	+ 51 76L	26L	0 + 51	25T 51L	- 51 - 25	76T 25T	- 76 - 51	101T 51T
12.0000	24.0000	+ 20 0	+ 40 60L	20L	+ 10 + 30	10T 30L	- 30 - 10	50T 10T	- 40 - 20	60T 20T
304.800	609.600	+ 51 0	+ 102 152L	51L	+ 26 + 76	25T 76L	- 76 - 25	127T 25T	- 102 - 51	153T 51T

Cone Fitting Practice for Metric System Bearings Class K and Class N (For "J" Prefix Bearings)

Bore Diameter			Rotating Cone			Rotating or Stationary Cone			Stationary Cone											
			Ground Shaft			Ground Shaft or Unground Shaft			Unground Shaft			Ground Shaft			Unground Shaft			Hardened and Ground Shaft		
			Steady Load with Moderate Shock			Heavy Loads, High Speed, or Shock			Moderate Loads, No Shock			Moderate Loads, No Shock			Sheaves, Wheels, Idlers			Wheel Spindles		
Inch/mm			.0001 Inch/Micrometers																	
Over	Incl	Tolerance	Shaft Diameter	Resultant Fit	Symbol	Shaft Diameter	Resultant Fit	Symbol	Shaft Diameter	Resultant Fit	Symbol	Shaft Diameter	Resultant Fit	Symbol	Shaft Diameter	Resultant Fit	Symbol	Shaft Diameter	Resultant Fit	Symbol
1.1811	1.9685	0 -5 -12	+4 +10 +9 +25	4T 15T 9T 37T	m6	+7 +13 +17 +33	7T 18T 17T 45T	n6	-6 0 -16 0	6L 5T 16L 12T	h6	-10 -4 -25 -9	10L 1T 25L 3T	g6	-10 -4 -25 -9	10L 1T 25L 3T	g6	-16 -10 -41 -25	16L 5L 41L 13L	f6
1.9685	3.1496	0 -6 0 -15	+5 +12 +11 +30	5T 18T 11T 45T	m6	+8 +15 +20 +39	8T 21T 20T 54T	n6	-7 0 -19 0	7L 6T 19L 15T	h6	-11 -4 -29 -10	11L 2T 29L 5T	g6	-11 -4 -29 -10	11L 2T 29L 5T	g6	-19 -12 -49 -30	19L 6L 49L 15L	f6
3.1496	4.7244	0 -8 0 -20	+5 +14 +13 +35	5T 22T 13T 55T	m6	+10 +19 +23 +45	10T 27T 23T 65T	n6	-9 0 -22 0	9L 8T 22L 20T	h6	-14 -5 -34 -12	14L 3T 34L 8T	g6	-14 -5 -34 -12	14L 3T 34L 8T	g6	-23 -14 -58 -36	23L 6L 58L 16L	f6
4.7244	7.0866	0 -10 0 -25	+12 +22 +27 +52	12T 32T 27T 77T	n6	+18 +28 +43 +68	18T 38T 43T 93T	p6	-10 0 -25 0	10L 10T 25L 25T	h6	-16 -6 -39 -14	16L 4T 39L 11T	g6	-16 -6 -39 -14	16L 4T 39L 11T	g6	-26 -16 -68 -43	26L 6L 68L 18L	f6
7.0866	9.8425	0 -12 0 -30	+14 +26 +31 +60	14T 38T 31T 90T	n6	+30 +42 +80 +109	30T 54T 80T 139T	r6	-12 0 -29 0	12L 12T 29L 30T	h6	-18 -6 -44 -15	18L 6T 44L 15T	g6	-18 -6 -44 -15	18L 6T 44T 15T	g6	-32 -20 -79 -50	32L 8L 79L 20L	f6

Cup Fitting Practice for Metric System Bearings Class K and Class N (For "J" Prefix Bearings)

Outside Diameter			Stationary Cup									Rotating Cup					
			Clamped or Floating			Adjustable			Nonadjustable			Nonadjustable or Sheaves—Clamped			Sheaves—Unclamped		
			Inch/mm			.0001 Inch/Micrometers											
Over	Incl	Tolerance	Housing Diameter	Resultant Fit	Symbol	Housing Diameter	Resultant Fit	Symbol	Housing Diameter	Resultant Fit	Symbol	Housing Diameter	Resultant Fit	Symbol	Housing Diameter	Resultant Fit	Symbol
3.1496	4.7244	0 -7 -18	+5 +19 +12 +47	5L 26L 12L 65L	G7	-5 +9 -13 +22	5T 16L 13T 40L	J7	-25 -11 -59 -24	25T 4T 59T 6T	P7	-30 -16 -76 -41	30T 9T 76T 23T	R7	-40 -20 100 -50	40T 13T 100T 32T	—
4.7244	5.9055	0 -8 0 -20	+6 +22 +14 +54	6L 30L 14L 74L	G7	-6 +10 -14 +26	6T 18L 14T 46L	J7	-28 -12 -68 -28	28T 4T 68T 8T	P7	-35 -20 -90 -50	35T 12T 90T 30T	R7	-45 -25 -115 -65	45T 17T 115T 45T	—
5.9055	7.0866	0 -10 0 -25	+6 +22 +14 +54	6L 32L 14L 79L	G7	-6 +10 -14 +26	6T 20L 14T 51L	J7	-28 -12 -68 -28	28T 2T 68T 3T	P7	-37 -21 -93 -53	37T 11T 93T 28T	R7	-45 -25 -115 -65	45T 15T 115T 40T	—
7.0866	9.8425	0 -12 0 -30	+6 +24 +15 +61	6L 36L 15L 91L	G7	-7 +11 -16 +30	7T 23L 16T 60L	J7	-32 -14 -79 -33	32T 2T 79T 3T	P7	-43 -25 -109 -63	43T 13T 109T 33T	R7	-50 -30 -125 -75	50T 18T 125T 45T	—
9.8425	12.4016	0 -14 0 -35	+7 +27 +17 +69	7L 41L 17L 104L	G7	-7 +13 -16 +36	7T 27L 16T 71L	J7	-34 -14 -88 -36	34T 0 88T 1T	P7	-51 -31 -130 -78	51T 17T 130T 43T	R7	-55 -35 -140 -90	55T 21T 140T 55T	—



BOWER[®]
An NTN brand manufactured in the USA

NTN Bearing Corporation of Canada

Corporate Office
305 Courtneypark Drive West
Mississauga, Ontario LSW 1 Y4
Tel: (905) 564-2700
Fax: (905) 564-9023
1-866-827-7950

Edmonton Branch
4608 97th Street
Edmonton, Alberta T6E 5N9
Tel: (780) 435-6200
Fax: (780) 435-3600
1-800-661-7320

Montreal Branch
4973 Levy Street
St. Laurent, Quebec H4R 2N9
Tel: (514) 333-8054
Fax: (514) 333-1078
1-800-361-6827

Vancouver
201-669 Ridley Place
Annacis Island
Delta, B.C. V3M 2Y9
Tel: (604) 517-1777
Fax: (604) 517-1794
1-800-972-8451

Toronto Branch
2880 Argentia Road, Unit #10
Mississauga, Ontario L5N 7X8
Tel: (905) 567-7770
Fax: (905) 567-6339
1-800-263-6124

NTN Bearing Corporation of America

Corporate Office
1600 East Bishop Court
Mt. Prospect, IL 60056-7604
Tel: (847) 298-7500
Fax: (847) 699-9744
1-800-468-6528

Central Sales Office
111 W. Washington Street, Suite 310
East Peoria, IL 61611
Tel: (309) 699-8600
Fax: (309) 699-8670
1-800-545-0434

Eastern Region
191 Sheree Blvd.
Suite 101
Exton, PA 19341
Tel: (610) 524-1477
(800) 394-4686
Fax: (610) 524-1577
1-800-394-4686

Great Lakes Sales Office
1600 East Bishop Court
Mt. Prospect, IL 60056-7604
Tel: (847) 699-4060
Fax: (847) 294-1364
1-800-252-8123

Southeast Region
5475 Peachtree Industrial Boulevard
Norcross, GA 30092
Tel: (770) 448-4710
Fax: (770) 448-6969
1-800-241-0568

Western Sales Office
5800 Campus Circle Dr E Ste 108 A
Irving, TX 76053-2703
Tel: (972) 751-1818
Fax: (972) 751-1836
1-800-441-0825

Automotive Group
39255 West 12 Mile Rd.
Farmington Hills, MI 48331
1-800-929-3892