

Air Cylinder



Series CA2

∅40, ∅50, ∅63, ∅80, ∅100

1 5 to 15% reduction in weight

By the adoption of die-cast cover, this model is 5 to 15% lighter than Series CA1.

2 Improved cushion capacity

Floating seal mechanism prevents shoot-out phenomenon due to cracking pressure at start-up.

3 Easy cushion valve adjustment

Use of a hexagon wrench key in cushion valve adjustment makes fine adjustment easy. The cushion valve does not protrude from the surface of the cover.

4 Able to absorb 30% more kinetic energy at the maximum.

With increased cushion volume and the adoption of a new cushion seal, this model, compared with Series CA1, is able to absorb 30% more kinetic energy at the maximum. The cushion seal has five times as long a service life.

5 Piston rod deflection reduced by 5 to 10%

Piston rod deflection is reduced by the improved accuracy of bushing and piston rod, which minimizes the clearance between these components.

6 Mounting dimensions are the same as those of Series CA1.

NPT thread and G thread are standardized.

Series variations

Series	Action	Type		Basic Built-in magnet	Standard variations			Cylinder Bore size (mm)
					With rod boot	Clean room Series	Copper-free	
Series CA2 Standard 	Double acting	Single rod Series CA2	Non-lube	●	●	●	40-50 63-80 100	
		Double rod Series CA2W	Non-lube	●	●	●		
Series CA2K Standard/Non-rotating rod 	Double acting	Single rod Series CA2K	Non-lube	●	●	●	40 50 63	
		Double rod Series CA2KW	Non-lube	●	●	●		
Series CA2□Q Low friction 	Double acting	Single rod Series CA2□Q	Non-lube	●	●	●	40 50 63 80 100	
Series CBA2 End lock 	Double acting	Single rod Series CBA2	Non-lube	●	●	●	40-50 63-80 100	
Series CA2□H Air-hydro 	Double acting	Single rod Series CA2□H	Air-hydro	●	●	●	40-50 63-80 100	
		Double rod Series CA2□WH	Air-hydro	●	●	●		

Air Cylinder/Standard: Double Acting Single Rod

Series CA2

ø40, ø50, ø63, ø80, ø100

How to Order

Without auto switch CA2 L [] 50 [] 100 JN

With auto switch CDA2 L [] 50 [] 100 JN Y7BW []

Mounting

B	Basic
L	Axial foot
F	Front flange
G	Rear flange
C	Single clevis
D	Double clevis
T	Centre trunnion

Tube material

Nil	Aluminum tube
F*	Steel tube

* Not available with auto switch.

Bore size

40	40 mm
50	50 mm
63	63 mm
80	80 mm
100	100 mm

Port thread type

Nil	Rc
TN	NPT
TF	G

Number of auto switches

Nil	2 pcs.
S	1 pc.
3	3 pcs.
n	"n" pcs.

Auto switch

Nil	Without auto switch
-----	---------------------

* Select an applicable auto switch model from the table below.
* D-Z7□, Y59□, and Y7□ are not mounted and are supplied loose. (Only the switch mounting brackets for these models are mounted.)

Cylinder suffix

Rod boot	Nil	Without
	J	Nylon tarpaulin
Cushion	K	Heat resistant tarpaulin
	Nil	With cushion on both sides
	N	Without cushion

* When more than one symbol is to be specified, indicate them in alphabetical order.

Cylinders with built-in magnets

If built-in magnet type is ordered without auto switch, leave the field for the auto switch type blank.
(Example) CDA2L40-100

Cylinder stroke (mm)

For more information, please refer to the next page.

Applicable Auto Switch : Refer to Best Pneumatics ② for detailed auto switch specifications.

Type	Special function	Electrical entry	Indicator light	Wiring (output)	Load voltage		Auto switch model	Lead wire length (m)*			Pre-wired connector	Applicable load		
					DC	AC		0.5 (Nil)	3 (L)	5 (Z)				
Reed switch	—	Grommet	Yes	3-wire (NPN equiv.)	—	5 V	—	Z76	●	●	—	—	IC circuit	—
				2-wire	24 V	12 V	—	100 V	Z73	●	●	●	—	—
	—	—	100 V, 200 V			A54	●	●	●	—				
	Diagnostic indication (2-colour indication)	Grommet	—	—	—	—	—	A59W	●	●	—	—	—	
Solid state switch	—	Grommet	Yes	3-wire (NPN)	24 V	5 V, 12 V	—	Y59A	●	●	○	○	IC circuit	Relay, PLC
				3-wire (PNP)				Y7P	●	●	○	○		
				2-wire	—	—	100 V, 200 V	J51	●	●	○	○	—	
								Y59B	●	●	○	○		
	Diagnostic indication (2-colour indication)	Grommet	Yes	3-wire (NPN)	24 V	5 V, 12 V	—	Y7NW	●	●	○	○	IC circuit	
								3-wire (PNP)	Y7PW	●	●	○		
	Water resistant (2-colour indication)	Grommet	Yes	2-wire	24 V	12 V	—	Y7BW	●	●	○	○	—	
								Y7BA	—	●	○	○		
	With diagnostic output (2-colour indication)	Grommet	Yes	4-wire (NPN)	24 V	5 V, 12 V	—	F59F	●	●	○	○	IC circuit	
								F5LF	●	●	○	○		
Latch type with diagnostic output (2-colour indication)	Grommet	Yes	2-wire	24 V	—	—	P5DW	—	●	●	○	—		
Magnetic field resistant (2-colour indication)	Grommet	Yes	2-wire	24 V	—	—						—		

* Lead wire length symbol 0.5 m.....Nil (Example) A54
3 m.....L (Example) A54L
5 m.....Z (Example) A54Z

* Solid state switches marked with "○" are produced upon receipt of order.

• In addition to the models in the above table, there are some other auto switches that are applicable. For more information, refer to page 15.

Air Cylinder/Standard: Double Acting Single Rod *Series CA2*

Standard type
CA2

Standard type
CA2W

Standard/Non-rotating rod
CA2K

Standard/Non-rotating rod
CA2KW

Low friction
CA2□□Q

End lock
CBA2

Air-hydro
CA2□H

Air-hydro
CA2W□H

Auto switch

Made to order

Precautions

Specifications

Fluid	Air
Action	Double acting
Proof pressure	1.5 MPa
Maximum operating pressure	1.0 MPa
Ambient and fluid temperature	Without auto switch: -10 to 70°C* With auto switch: -10 to 60°C*
Minimum operating pressure	0.05 MPa
Piston speed	50 to 500 mm/s*
Cushion	Air cushion
Thread tolerance	JIS class 2
Stroke length tolerance	To 250 st : $^{+1.0}_0$ 251 to 1000 st : $^{+1.4}_0$ 1001 to 1500 st : $^{+1.8}_0$
Lubrication	Not required (Non-lube)
Mounting	Basic, Foot, Front flange, Rear flange Single clevis, Double clevis, Centre trunnion

* With no freezing. * Operate within the range of absorbing kinetic energy. (Refer to page 3.)

Standard Stroke/ In case of a type with auto switch, please also refer to the table of minimum strokes for auto switch mounting on page 13.

Bore size (mm)	Standard stroke (mm)*	Long stroke (L and F only)
40	25, 50, 75, 100, 125, 150, 175, 200, 250, 300, 350, 400, 450, 500	800
50, 63	25, 50, 75, 100, 125, 150, 175, 200, 250, 300, 350, 400, 500, 600	1200
80, 100	25, 50, 75, 100, 125, 150, 175, 200, 250, 300, 350, 400, 450, 500, 600, 700	ø80 : 1400 ø100: 1500

* Intermediate strokes not listed above are produced upon receipt of order.

Rod Boot Material

Symbol	Rod boot material	Max. ambient temperature
J	Nylon tarpaulin	70°C
K	Heat resistant tarpaulin	110°C*

* Maximum ambient temperature for the rod boot itself.

Accessory

Mounting		Basic	Axial foot	Front flange	Rear flange	Single clevis type	Double clevis type	Centre trunnion
		Standard equipment	Rod end nut	●	●	●	●	●
	Clevis pin	—	—	—	—	—	—	
Options	Single knuckle joint	●	●	●	●	●	●	
	Double knuckle joint (with pin)	●	●	●	●	●	●	
	With rod boot	●	●	●	●	●	●	

Minimum Stroke for Auto Switch Mounting

⚠ Caution

① The minimum stroke for mounting varies with the auto switch type and mounting type of the cylinder. In particular, the centre trunnion type needs careful attention. (For more information, please refer to page 13.)

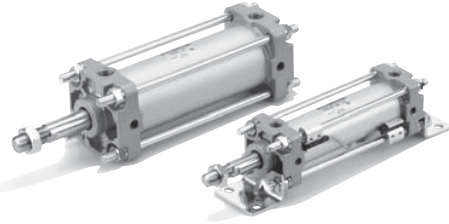

JIS symbol

Double acting type

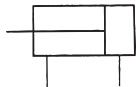

Made to Order Specifications
For more information, please refer to page 64.

Symbol	Specifications/Contents
—XA□	Change of rod end shape
—XB5	Oversized rod
—XB6	Heat resistant (150°C)
—XC3	Special port positions
—XC4	With heavy duty scraper
—XC5	Heat resistant (110°C)
—XC6	Piston rod and rod end nut made of stainless steel
—XC7	Tie-rod, cushion valve, and tie-rod nut and similar parts made of stainless steel
—XC8	Adjustable stroke/Extension
—XC9	Adjustable stroke/Retraction
—XC10	Dual stroke/Double rod
—XC11	Dual stroke/Single rod
—XC12	Tandem type
—XC14	Change of trunnion bracket mounting position
—XC15	Change of tie-rod length
—XC22	Fluoro rubber seal
—XC27	Double clevis pin and double knuckle pin made of stainless steel
—XC28	Compact flange made of SS400
—XC29	Double knuckle joint with spring pin
—XC30	Front trunnion
—XC35	With coil scraper
—XC58	Water resistant/Built-in hard plastic magnet
—XC59	Fluoro rubber seal/Built-in hard plastic magnet

Series CA2

Weight/Aluminum Tube (Steel tube)

Bore size (mm)		40	50	63	80	100	
Basic weight	Basic	Aluminum tube	0.86	1.29	1.84	3.10	4.18
		Steel tube	0.92	1.35	1.93	3.30	4.45
	Axial foot	Aluminum tube	1.05	1.51	2.18	3.77	5.17
		Steel tube	1.11	1.57	2.27	3.97	5.44
	Flange	Aluminum tube	1.23	1.74	2.63	4.55	6.10
		Steel tube	1.29	1.80	2.72	4.75	6.37
	Single clevis	Aluminum tube	1.09	1.63	2.47	4.21	5.96
		Steel tube	1.15	1.69	2.56	4.41	6.23
	Single clevis	Aluminum tube	1.13	1.72	2.63	4.50	6.48
		Steel tube	1.19	1.78	2.72	4.70	6.75
	Trunnion	Aluminum tube	1.22	1.77	2.64	4.65	6.46
		Steel tube	1.28	1.83	2.73	4.85	6.73
Additional weight by each 50 mm stroke	All mounting brackets	Aluminum tube	0.20	0.25	0.31	0.46	0.58
	Steel tube	0.28	0.35	0.43	0.70	0.87	
Accessories	Single knuckle	0.23	0.26	0.26	0.60	0.83	
	Double knuckle (with pin)	0.37	0.43	0.43	0.87	1.27	

Calculation example: CA2L40-100 (axial foot type, $\phi 40$, 100st)

- Basic weight.....1.05 kg
 - Additional weight.....0.20/50st
 - Cylinder stroke.....100st
- $1.05 + 0.20 \times 100 / 50 = 1.45$ kg

Auto Switch Mounting Bracket Part No.

Auto switch model	Bore size (mm)				
	40	50	63	80	100
D-A5□/A6□ D-A59W D-F5□/J5□ D-F5□W/J59W D-F5□F/F5NTL	BT-04	BT-04	BT-06	BT-08	BT-08
*** D-A3□/A44 *** D-G39/K39	BDS-04M	BDS-05M	BMBI-063	BMBI-080	BMBI-100
*** D-B5□/B64 *** D-B59W *** D-G5□/K59 *** D-G5□W/K59W *** D-G59F *** D-G5NTL	BH2-040	BA5-050	BAF-06	BAF-08	BAF-10
* D-A3□C/A44C * D-G39C/K39C	BA3-040	BA3-050	BA3-063	BA3-080	BA3-100
D-Z7□/Z80 D-Y59□/Y69□ D-Y7P/Y7PV D-Y7□W D-Y7□WV D-Y7BAL	BA4-040	BA4-040	BA4-063	BA4-080	BA4-080
D-P5DWL	BAP2-040	BAP2-040	BAP2-063	BAP2-080	BAP2-080

* Mounting brackets are attached to models D-A3□C, A44C, G39C and K39C. When placing an order, indicate one of the following part numbers according to the cylinder size.

(Example) $\phi 40$...D-A3□C-4, $\phi 63$...D-A3□C-6, $\phi 100$...D-A3□C-10
 $\phi 50$...D-A3□C-5, $\phi 80$...D-A3□C-8

When other brackets are ordered separately, order by the above part numbers.

** Stainless steel mounting screw kit

The following stainless steel mounting screw kits (including set screws) are available if the operating environment requires. (The mounting bracket and band are not included and must be ordered separately.)

BBA1: D-A5/A6/F5/J5
BBA3: D-B5/B6/G5/K5

When a switch model D-F5BAL or G5BAL is mounted on the cylinder at the time of shipment, the above stainless steel screws are used. When the switch is shipped alone, BBA1 or BBA3 is attached.

*** Series CDA2 models vary in the thickness of the cylinder tube wall. In cases where the band mount type is used as an applicable auto switch, select the part number of the new band referring to page 79 whenever the cylinder model is changed.

Mounting Bracket

Bore size (mm)	40	50	63	80	100
Axial foot*	CA2-L04	CA2-L05	CA2-L06	CA2-L08	CA2-L10
Flange	CA2-F04	CA2-F05	CA2-F06	CA2-F08	CA2-F10
Single clevis	CA2-C04	CA2-C05	CA2-C06	CA2-C08	CA2-C10
Double clevis**	CA2-D04	CA2-D05	CA2-D06	CA2-D08	CA2-D10

* When axial foot brackets are used, two pieces should be ordered for each cylinder.

** Double clevis type is packed with clevis pin, flat washer and cotter pin.

Allowable Kinetic Energy

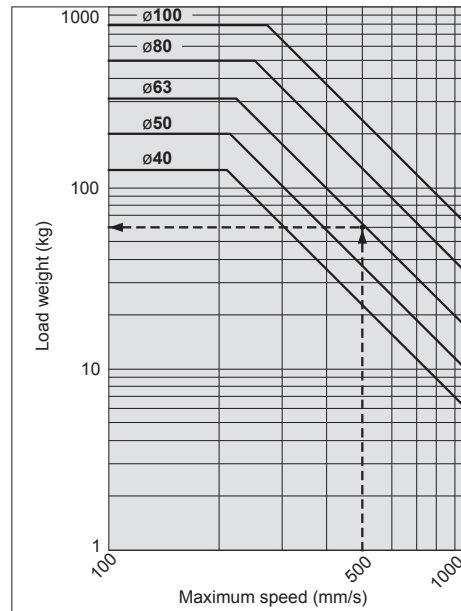

(Example) Find the upper limit of rod end load when an air cylinder of $\phi 63$ is operated at 500 mm/s. From a point indicating 500 mm/s on the axis of abscissas, extend a line upward and find a point where it intersects with a line for the 63 mm bore size. Extend a line from the intersection to the left and find a load weight 60 kg.

Air Cylinder/Standard: Double Acting Single Rod **Series CA2**

Clean Series

10 – CA2 Mounting Bore size Stroke Suffix

↓ Clean series with relief port

This cylinder can be operated in a class 100 clean room. The rod portion of the actuator has a double seal construction and a relief port is provided to discharge the exhaust air directly outside of the clean room.

Specifications

Action	Double acting single rod
Bore size	ø40, ø50, ø63
Maximum operating pressure	1MPa
Minimum operating pressure	0.05MPa
Cushion	Air cushion
Piping	Screw-in piping
Relief port size	M5
Piston speed	50 to 500 mm/s*
Mounting	Basic, Axial foot, Front flange, Rear flange

* Auto switch capable

* Operate within the range of absorbable kinetic energy. (Refer to page 3.)

Construction

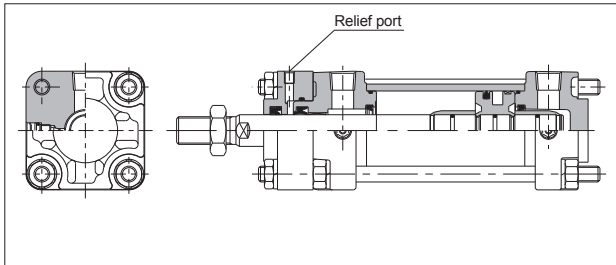

Copper Free (applicable to CRT production)

20 – CA2 Mounting Bore size Stroke Suffix

↓ Copper free

To eliminate any influences of copper ions or fluororesin on colour CRTs, copper materials have been nickel plated or replaced with non-copper materials, thus preventing the generation of copperions.

Specifications

Action	Double acting single rod
Bore size	ø40, ø50, ø63, ø80, ø100
Maximum operating pressure	1MPa
Minimum operating pressure	0.05MPa
Cushion	Air cushion
Piping	Screw-in piping
Piston speed	50 to 500 mm/s*
Mounting	Basic, Axial foot, Front flange, Rear flange, Single clevis, Double clevis, Centre trunnion

* Auto switch capable

* Operate within the range of absorbable kinetic energy. (Refer to page 3.)

Construction

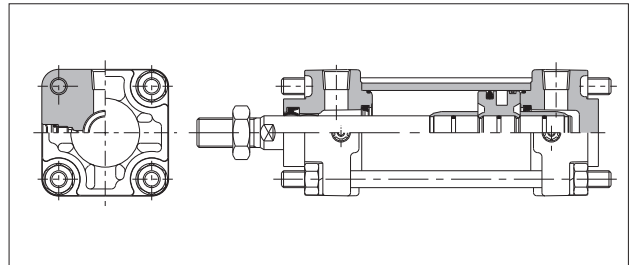

Standard type
CA2

Standard type
CA2W

Standard/Non-rotating rod
CA2K

Standard/Non-rotating rod
CA2KW

Low friction
CA2□Q

End lock
CBA2

Air-hydro
CA2□H

Air-hydro
CA2W□H

Auto switch

Made to order

Precautions

Series CA2

Construction

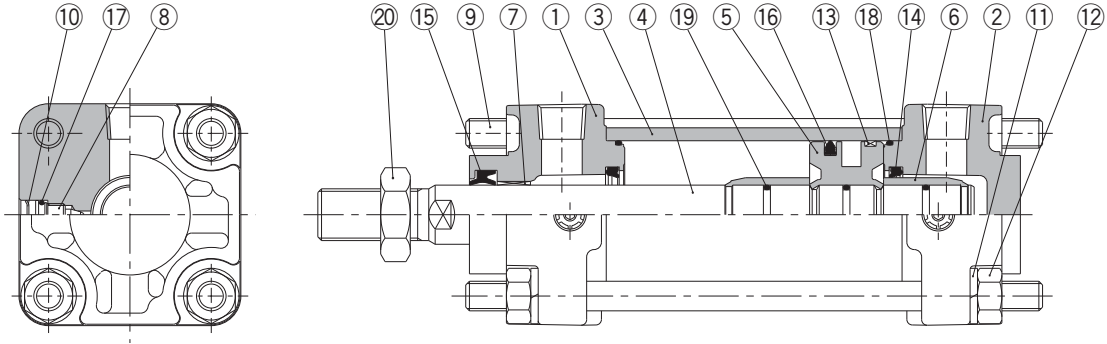

Parts List

No.	Description	Material	Note
1	Rod cover	Die-cast aluminum	Metallic painted
2	Head cover	Die-cast aluminum	Metallic painted
3	Cylinder tube	Aluminum alloy	Hard anodized
4	Piston rod	Carbon steel	Hard chromium electroplated
5	Piston	Aluminum alloy	Chromated
6	Cushion ring	Brass	
7	Bushing	Lead-bronze casting	
8	Cushion valve	Steel wire	Nickel plated
9	Tie-rod	Carbon steel	Corrosion resistant chromated
10	Snap ring	Spring steel	
11	Spring washer	Steel wire	Chromated
12	Tie-rod nut	Rolled steel	Nickel plated
13	Wear ring	Resin	
14	Cushion seal	Urethane	
15	Rod seal	NBR	
16	Piston seal	NBR	
17	Cushion valve seal	NBR	
18	Cylinder tube gasket	NBR	
19	Piston gasket	NBR	O-ring
20	Rod end nut	Rolled steel	Nickel plated

Replacement Parts: Seal Kits

Bore size (mm)	Seal kit No.	Content
	Air cylinder	
40	MB40-PS	Consists of numbers ⑭, ⑮, ⑯, and ⑰ above.
50	MB50-PS	
63	MB63-PS	
80	MB80-PS	
100	MB100-PS	

* The seal kits consist of items ⑭, ⑮, ⑯, and ⑰. Please order them by using the seal kit number corresponding to each bore size.

Air Cylinder/Standard: Double Acting Single Rod *Series CA2*

Standard type
CA2

Standard type
CA2W

Standard/Non-rotating rod
CA2K

Standard/Non-rotating rod
CA2KW

Low friction
CA2□Q

End lock
CBA2

Air-hydro
CA2□H

Air-hydro
CA2W□H

Auto switch

Made to order

Precautions

Basic/CA2B

With rod boot

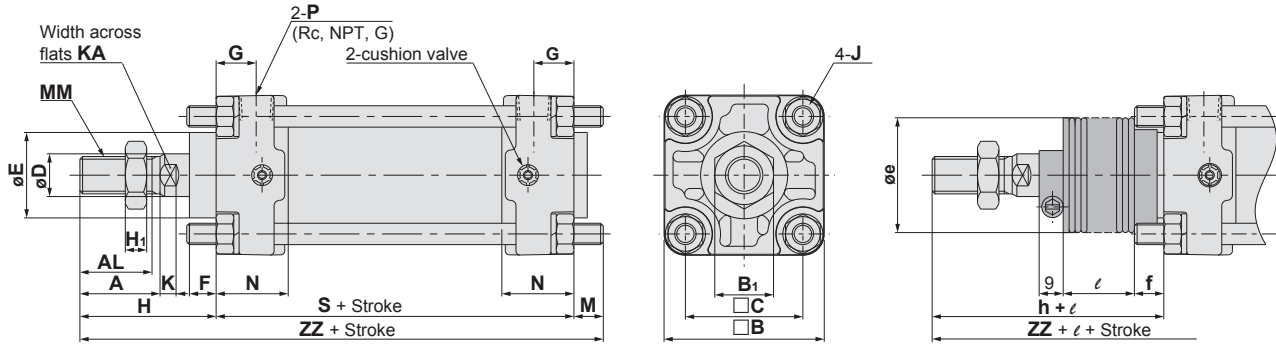

Bore size (mm)	Stroke range (mm)		(mm)																
	Without rod boot	With rod boot	A	AL	□B	B ₁	□C	D	E	F	G	H ₁	J	K	KA	M	MM	N	P
40	up to 500	20 to 500	30	27	60	22	44	16	32	10	15	8	M8	6	14	11	M14 x 1.5	27	1/4
50	up to 600	20 to 600	35	32	70	27	52	20	40	10	17	11	M8	7	18	11	M18 x 1.5	30	3/8
63	up to 600	20 to 600	35	32	85	27	64	20	40	10	17	11	M10 x 1.25	7	18	14	M18 x 1.5	31	3/8
80	up to 750	20 to 750	40	37	102	32	78	25	52	14	21	13	M12	10	22	17	M22 x 1.5	37	1/2
100	up to 750	20 to 750	40	37	116	41	92	30	52	14	21	16	M12	10	26	17	M26 x 1.5	40	1/2

Bore size (mm)	S	Without rod boot		With rod boot				
		H	ZZ	e	f	h	ℓ	ZZ
40	84	51	146	43	11.2	59	1/4 stroke	154
50	90	58	159	52	11.2	66	1/4 stroke	167
63	98	58	170	52	11.2	66	1/4 stroke	178
80	116	71	204	65	12.5	80	1/4 stroke	213
100	126	72	215	65	14	81	1/4 stroke	224

Series CA2

Axial foot/CA2L

With rod boot

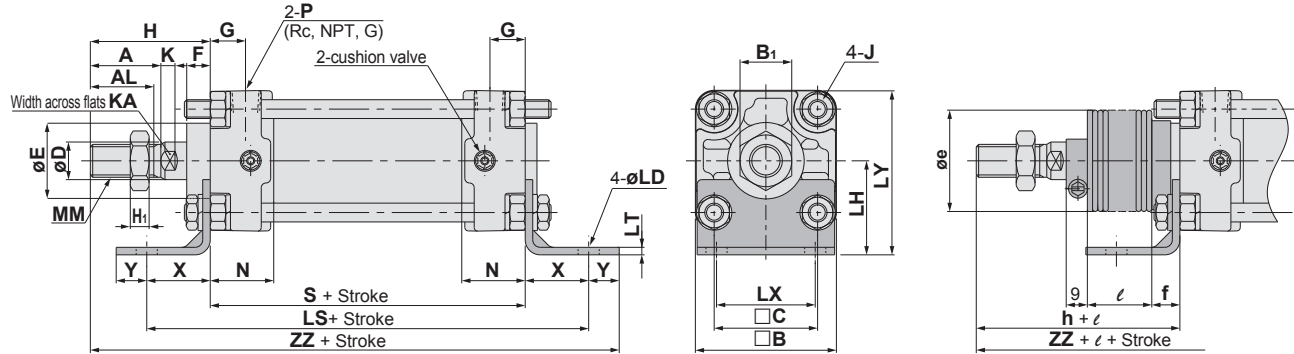

Long stroke

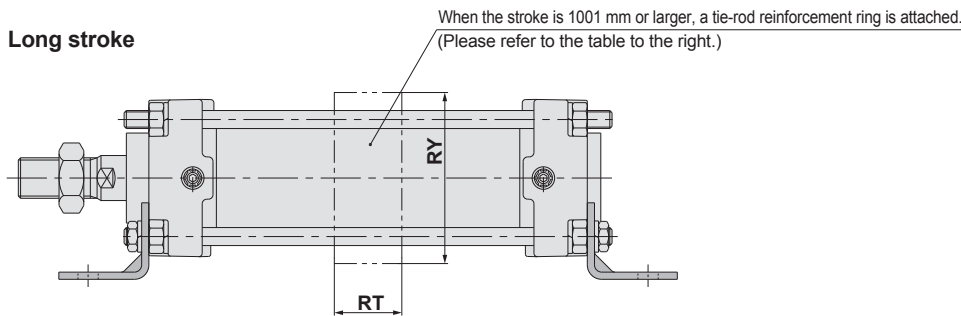

For Long Strokes

(mm)

Bore size (mm)	Stroke range (mm)	RT	RY
40	501 to 800	—	—
	1001 to 1200	30	76
50	601 to 1000	—	—
	1001 to 1200	40	92
63	751 to 1000	—	—
	1001 to 1400	45	112
80	751 to 1000	—	—
	1001 to 1500	50	136

(mm)

Bore size (mm)	Stroke range (mm)		A	AL	□B	B ₁	□C	D	E	F	G	H ₁	J	K	KA	LD	LH	LS	LT
	Without rod boot	With rod boot																	
40	up to 500	20 to 500	30	27	60	22	44	16	32	10	15	8	M8	6	14	9.0	40	138	3.2
50	up to 600	20 to 600	35	32	70	27	52	20	40	10	17	11	M8	7	18	9.0	45	144	3.2
63	up to 600	20 to 600	35	32	85	27	64	20	40	10	17	11	M10 x 1.25	7	18	11.5	50	166	3.2
80	up to 750	20 to 750	40	37	102	32	78	25	52	14	21	13	M12	10	22	13.5	65	204	4.5
100	up to 750	20 to 750	40	37	116	41	92	30	52	14	21	16	M12	10	26	13.5	75	212	6.0

Bore size (mm)	LX	LY	MM	N	P	S	X	Y	Without rod boot		With rod boot				
									H	ZZ	e	f	n	ℓ	ZZ
40	42	70	M14 x 1.5	27	1/4	84	27	13	51	175	43	11.2	59	1/4 stroke	183
50	50	80	M18 x 1.5	30	3/8	90	27	13	58	188	52	11.2	66	1/4 stroke	196
63	59	93	M18 x 1.5	31	3/8	98	34	16	58	206	52	11.2	66	1/4 stroke	214
80	76	116	M22 x 1.5	37	1/2	116	44	16	71	247	65	12.5	80	1/4 stroke	256
100	92	133	M26 x 1.5	40	1/2	126	43	17	72	258	65	14.0	81	1/4 stroke	267

Front flange/CA2F

With rod boot

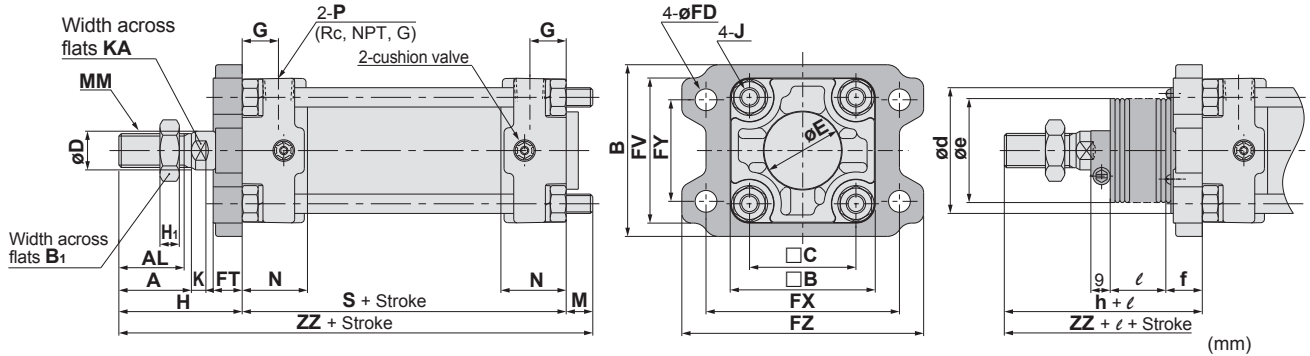

Bore size (mm)	Stroke range (mm)			A	AL	B	□B	B ₁	□C	D	E	FV	FD	FT	FX	FY	FZ	G	H ₁	J
	Without rod boot	With rod boot	Long stroke range (mm)																	
40	up to 500	20 to 500	501 to 800	30	27	71	60	22	44	16	32	60	9.0	12	80	42	100	15	8	M8
50	up to 600	20 to 600	601 to 1000	35	32	81	70	27	52	20	40	70	9.0	12	90	50	110	17	11	M8
63	up to 600	20 to 600	601 to 1000	35	32	101	85	27	64	20	40	86	11.5	15	105	59	130	17	11	M10 x 1.25
80	up to 750	20 to 750	751 to 1000	40	37	119	102	32	78	25	52	102	13.5	18	130	76	160	21	13	M12
100	up to 750	20 to 750	751 to 1000	40	37	133	116	41	92	30	52	116	13.5	18	150	92	180	21	16	M12

Bore size (mm)	K	KA	M	MM	N	P	S	Without rod boot		With rod boot					
								H	ZZ	d*	e	f	h	ℓ	ZZ
40	6	14	11	M14 x 1.5	27	1/4	84	51	146	52	43	15	59	1/4 stroke	154
50	7	18	11	M18 x 1.5	30	3/8	90	58	159	58	52	15	66	1/4 stroke	167
63	7	18	14	M18 x 1.5	31	3/8	98	58	170	58	52	17.5	66	1/4 stroke	178
80	10	22	17	M22 x 1.5	37	1/2	116	71	204	80	65	21.5	80	1/4 stroke	213
100	10	26	17	M26 x 1.5	40	1/2	126	72	215	80	65	21.5	81	1/4 stroke	224

* If a hole is provided to accommodate the rod boot when the air cylinder is mounted, make the hole diameter larger than the outside diameter of the rod boot mounting bracket ød.

Long Stroke (a stroke of 1001 mm or larger)

With rod boot

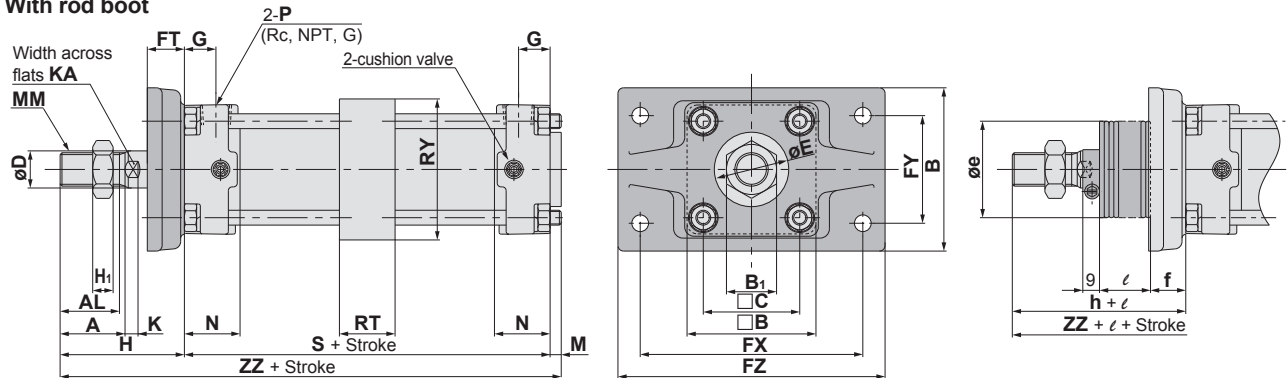

Bore size (mm)	Stroke range (mm)	A	AL	B	□B	B ₁	□C	D	E	FD	FT	FX	FY	FZ	G	H ₁	J	K	KA
63	1001 to 1200	35	32	105	85	27	64	20	40	11.5	23	140	64	170	17	11	M10 x 1.25	7	18
80	1001 to 1400	40	37	124	102	32	78	25	52	13.5	28	164	84	198	21	13	M12	10	22
100	1001 to 1500	40	37	140	116	41	92	30	52	13.5	29	180	100	220	21	16	M12	10	26

Bore size (mm)	M	MM	N	P	RT	RY	S	Without rod boot		With rod boot					
								H	ZZ	e*	f	h	ℓ	ZZ	
50	6	M18 x 1.5	30	3/8	30	76	90	67	163	52	19	66	1/4 stroke	162	
63	10	M18 x 1.5	31	3/8	40	92	98	71	179	52	19	66	1/4 stroke	174	
80	12	M22 x 1.5	37	1/2	45	112	116	87	215	65	21	80	1/4 stroke	208	
100	12	M26 x 1.5	40	1/2	50	136	126	89	227	65	21	81	1/4 stroke	219	

* If a hole is provided to accommodate the rod boot when the air cylinder is mounted, make the hole diameter larger than the outside diameter of the rod boot øe.

Series CA2

Rear flange/CA2G

With rod boot

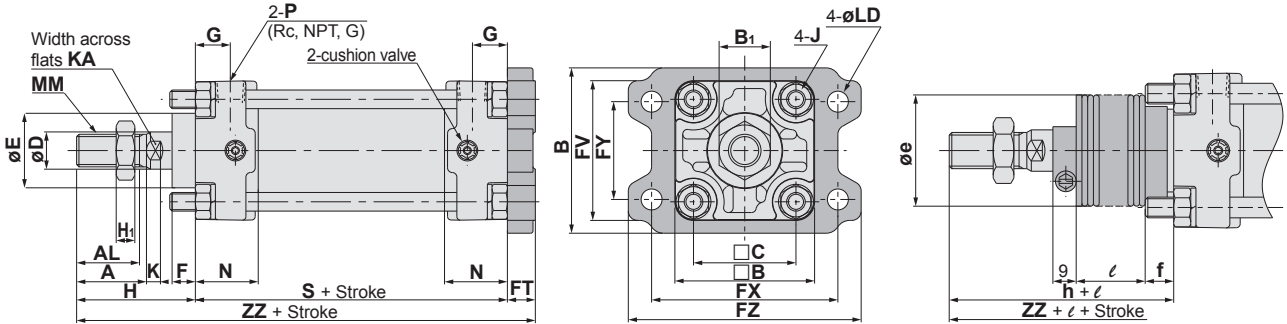

(mm)

Bore size (mm)	Stroke range (mm)		A	AL	B	□B	B ₁	□C	D	E	F	FV	FD	FT	FX	FY	FZ	G	H ₁	J
	Without rod boot	With rod boot																		
40	up to 500	20 to 500	30	27	71	60	22	44	16	32	10	60	9.0	12	80	42	100	15	8	M8
50	up to 600	20 to 600	35	32	81	70	27	52	20	40	10	70	9.0	12	90	50	110	17	11	M8
63	up to 600	20 to 600	35	32	101	85	27	64	20	40	10	86	11.5	15	105	59	130	17	11	M10 x 1.25
80	up to 750	20 to 750	40	37	119	102	32	78	25	52	14	102	13.5	18	130	76	160	21	13	M12
100	up to 750	20 to 750	40	37	133	116	41	92	30	52	14	116	13.5	18	150	92	180	21	16	M12

Bore size (mm)	K	KA	MM	N	P	S	Without rod boot		With rod boot				
							H	ZZ	e	f	h	ℓ	ZZ
40	6	14	M14 x 1.5	27	1/4	84	51	147	43	11.2	59	1/4 stroke	155
50	7	18	M18 x 1.5	30	3/8	90	58	160	52	11.2	66	1/4 stroke	168
63	7	18	M18 x 1.5	31	3/8	98	58	171	52	11.2	66	1/4 stroke	179
80	10	22	M22 x 1.5	37	1/2	116	71	205	65	12.5	80	1/4 stroke	214
100	10	26	M26 x 1.5	40	1/2	126	72	216	65	14.0	81	1/4 stroke	225

Single Clevis/CA2C

With rod boot

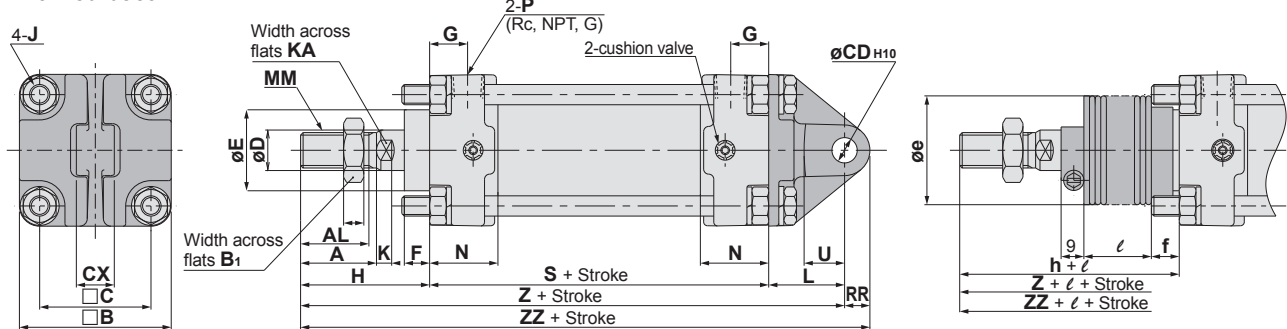

(mm)

Bore size (mm)	Stroke range (mm)		A	AL	□B	B ₁	□C	CD ^{H10}	CX	D	E	F	G	H ₁	J	K	KA
	Without rod boot	With rod boot															
40	up to 500	20 to 500	30	27	60	22	44	10 ₀ ^{+0.058}	15.0 ₀ ^{-0.1}	16	32	10	15	8	M8	6	14
50	up to 600	20 to 600	35	32	70	27	52	12 ₀ ^{+0.070}	18.0 ₀ ^{-0.1}	20	40	10	17	11	M8	7	18
63	up to 600	20 to 600	35	32	85	27	64	16 ₀ ^{+0.070}	25.0 ₀ ^{-0.1}	20	40	10	17	11	M10 x 1.25	7	18
80	up to 750	20 to 750	40	37	102	32	78	20 ₀ ^{+0.084}	31.5 ₀ ^{-0.1}	25	52	14	21	13	M12	10	22
100	up to 750	20 to 750	40	37	116	41	92	25 ₀ ^{+0.084}	35.5 ₀ ^{-0.1}	30	52	14	21	16	M12	10	26

Bore size (mm)	L	MM	N	P	RR	S	U	Without rod boot		With rod boot						
								H	Z	ZZ	e	f	h	ℓ	Z	ZZ
40	30	M14 x 1.5	27	1/4	10	84	16	51	165	175	43	11.2	59	1/4 stroke	173	183
50	35	M18 x 1.5	30	3/8	12	90	19	58	183	195	52	11.2	66	1/4 stroke	191	203
63	40	M18 x 1.5	31	3/8	16	98	23	58	196	212	52	11.2	66	1/4 stroke	204	220
80	48	M22 x 1.5	37	1/2	20	116	28	71	235	255	65	12.5	80	1/4 stroke	244	264
100	58	M26 x 1.5	40	1/2	25	126	36	72	256	281	65	14.0	81	1/4 stroke	265	290

Air Cylinder/Standard: Double Acting Single Rod **Series CA2**

Double Clevis/CA2D

With rod boot

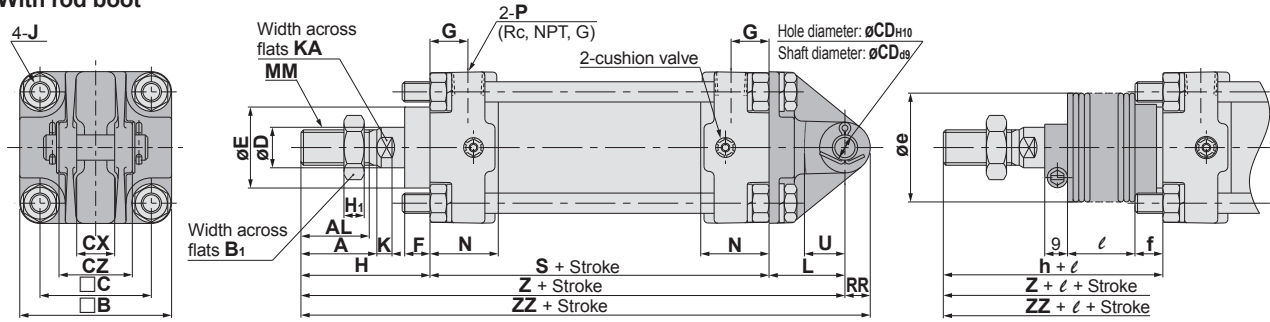

* Double clevis and double knuckle joint types are packed with pins and snap rings. (mm)

Bore size (mm)	Stroke range (mm)		A	AL	□B	B ₁	□C	CD	CX	CZ	D	E	F	G	H ₁	J	K	KA
	Without rod boot	With rod boot																
40	up to 500	20 to 500	30	27	60	22	44	10 ₀ ^{+0.058}	15.0 _{+0.1} ^{+0.3}	29.5	16	32	10	15	8	M8	6	14
50	up to 600	20 to 600	35	32	70	27	52	12 ₀ ^{+0.070}	18.0 _{+0.1} ^{+0.3}	38	20	40	10	17	11	M8	7	18
63	up to 600	20 to 600	35	32	85	27	64	16 ₀ ^{+0.070}	25.0 _{+0.1} ^{+0.3}	49	20	40	10	17	11	M10 x 1.25	7	18
80	up to 750	20 to 750	40	37	102	32	78	20 ₀ ^{+0.084}	31.5 _{+0.1} ^{+0.3}	61	25	52	14	21	13	M12	10	22
100	up to 750	20 to 750	40	37	116	41	92	25 ₀ ^{+0.084}	35.5 _{+0.1} ^{+0.3}	64	30	52	14	21	16	M12	10	26

Bore size (mm)	L	MM	N	P	RR	S	U	Without rod boot			With rod boot					
								H	Z	ZZ	e	f	h	ℓ	Z	ZZ
40	30	M14 x 1.5	27	1/4	10	84	16	51	165	175	43	11.2	59	1/4 stroke	173	183
50	35	M18 x 1.5	30	3/8	12	90	19	58	183	195	52	11.2	66	1/4 stroke	191	203
63	40	M18 x 1.5	31	3/8	16	98	23	58	196	212	52	11.2	66	1/4 stroke	204	220
80	48	M22 x 1.5	37	1/2	20	116	28	71	235	255	65	12.5	80	1/4 stroke	244	264
100	58	M26 x 1.5	40	1/2	25	126	36	72	256	281	65	14.0	81	1/4 stroke	265	290

* Packed with clevis pin, flat washer and cotter pin.

Center Trunnion/CA2T

With rod boot

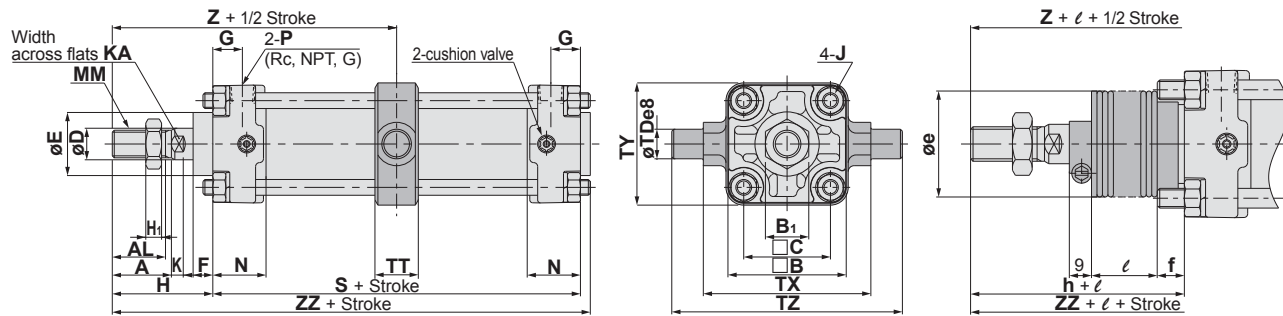

Bore size (mm)	Stroke range (mm)		A	AL	□B	B ₁	□C	D	E	F	G	H ₁	J	K	KA	MM	N	P
	Without rod boot	With rod boot																
40	up to 500	20 to 500	30	27	60	22	44	16	32	10	15	8	M8	6	14	M14 x 1.5	27	1/4
50	up to 600	20 to 600	35	32	70	27	52	20	40	10	17	11	M8	7	18	M18 x 1.5	30	3/8
63	up to 600	20 to 600	35	32	85	27	64	20	40	10	17	11	M10 x 1.25	7	18	M18 x 1.5	31	3/8
80	up to 750	20 to 750	40	37	102	32	78	25	52	14	21	13	M12	10	22	M22 x 1.5	37	1/2
100	up to 750	20 to 750	40	37	116	41	92	30	52	14	21	16	M12	10	26	M26 x 1.5	40	1/2

Bore size (mm)	S	TDe8	TT	TX	TY	TZ	Without rod boot			With rod boot					
							H	Z	ZZ	e	f	h	ℓ	Z	ZZ
40	84	15 _{-0.059} ^{-0.032}	22	85	62	117	51	93	140	43	11.2	59	1/4 stroke	101	148
50	90	15 _{-0.059} ^{-0.032}	22	95	74	127	58	103	154	52	11.2	66	1/4 stroke	111	162
63	98	18 _{-0.059} ^{-0.032}	28	110	90	148	58	107	162	52	11.2	66	1/4 stroke	115	170
80	116	25 _{-0.073} ^{-0.040}	34	140	110	192	71	129	194	65	12.5	80	1/4 stroke	138	203
100	126	25 _{-0.073} ^{-0.040}	40	162	130	214	72	135	206	65	14.0	81	1/4 stroke	144	215

Series CA2

Trunnion and Double Clevis Mounting Brackets

- Strength is the same as cylinder brackets.

Applicable Series

Bracket types	Applicable series
Trunnion mounting bracket	CA2, CA2W, CA2WK CA2K, CA2Q, CBA2
Double clevis bracket	CA2, CA2K, CA2Q, CBA2

Description	Bore size	CA2□40	CA2□50	CA2□63	CA2□80	CA2□100
Trunnion mounting bracket		CA2-S04		CA2-S06	MB-S10	
Double clevis bracket		CA2-B04	CA2-B05	CA2-B06	CA2-B08	CA2-B10

- Note) 1. The above brackets cannot be specified in the part number of the cylinder.
 2. They must be ordered separately from the cylinder.
 3. When the trunnion brackets are specified, two pieces should be ordered for each cylinder.

* Confirm SMC at the time of mounting.

Trunnion bracket

Material/Cast iron

* This assembly drawing is provided as a reference. The trunnion bracket must be ordered separately.

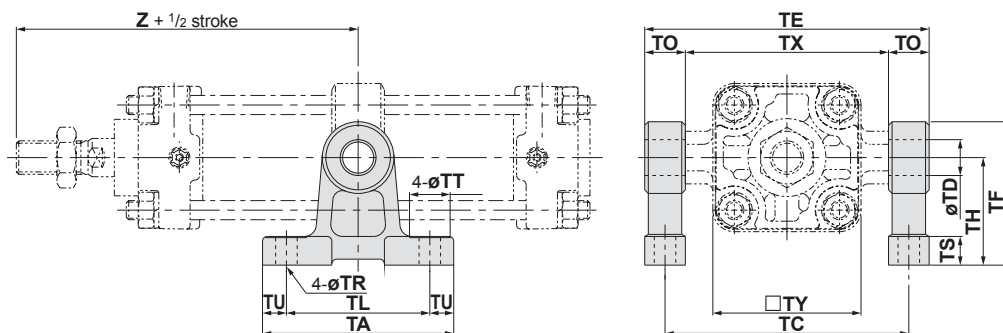

Part no.	Bore size (mm)	TA	TL	TU	TC	TX	TE	TO	TR	TT	TS	TH	TF	TY	Z	TD-H10 (Hole)
CA2-S04	40	80	60	10	102	85	119	17	9	17	12	45	60	62	93	15 ^{+0.070} ₀
	50	80	60	10	112	95	129	17	9	17	12	45	60	74	103	15 ^{+0.070} ₀
CA2-S06	63	100	70	15	130	110	150	20	11	22	14	55	73	90	107	18 ^{+0.070} ₀
MB-S10	80	120	90	15	166	140	192	26	13.5	24	17	75	100	110	129	25 ^{+0.084} ₀
	100	120	90	15	188	162	214	26	13.5	24	17	75	100	130	135	25 ^{+0.084} ₀

Double clevis bracket

Material/Cast iron

Rotation

Bore size (mm)	A°	B°	A° + B° + 90°
40 to 100	12°	60°	162°

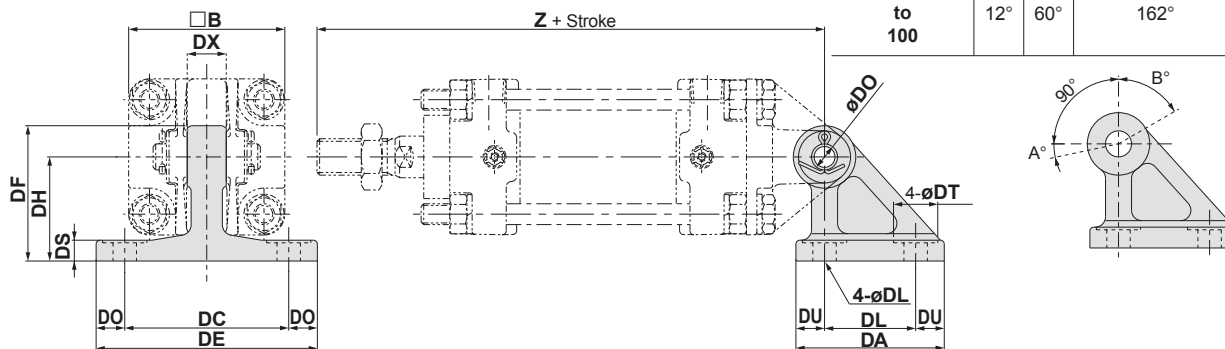

Note) This assembly drawing is provided as a reference. The trunnion bracket must be ordered separately.

Part no.	Bore size (mm)	DA	DL	DU	DC	DX	DE	DO	DR	DT	DS	DH	DF	B	Z	DDH10 (Hole)
CA2-B04	40	57	35	11	65	15	85	10	9	17	8	40	52	60	165	10 ^{+0.058} ₀
CA2-B05	50	57	35	11	65	18	85	10	9	17	8	40	52	70	183	12 ^{+0.070} ₀
CA2-B06	63	67	40	13.5	80	25	105	12.5	11	22	10	50	66	85	196	16 ^{+0.070} ₀
CA2-B08	80	93	60	16.5	100	31.5	130	15	13.5	24	12	65	90	102	235	20 ^{+0.084} ₀
CA2-B10	100	93	60	16.5	100	35.5	130	15	13.5	24	12	65	90	116	256	25 ^{+0.084} ₀

* Double clevis and double knuckle joint types are packed with pins and snap rings.

(Common to Series CA2) Accessory Dimensions

Standard type
CA2

Standard type
CA2W

Standard/Non-rotating rod
CA2K

Standard/Non-rotating rod
CA2KW

Low friction
CA2□Q

End lock
CBA2

Air-hydro
CA2□H

Air-hydro
CA2W□H

Auto switch

Made to order

Precautions

Y Type Double Knuckle Joint

* Double clevis and double knuckle joint types are packed with pins and snap rings.

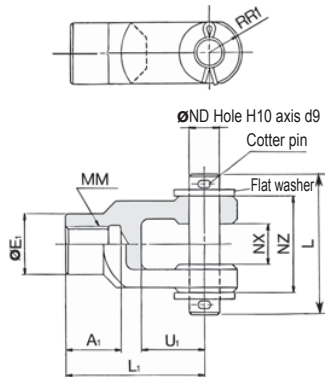

Material: Cast iron (mm)

Part no.	Applicable bore size (mm)	A1	E1	L1	MM	RR1	U1	ND	NX	NZ	L	Cotter pin size	Flat washer size
Y-04D	40	22	24	55	M14 x 1.5	13	25	12	16 ^{+0.3} _{-0.1}	38	55.5	ø3 x 18ℓ	Polished round 12
Y-05D	50, 63	27	28	60	M18 x 1.5	15	27	12	16 ^{+0.3} _{-0.1}	38	55.5	ø3 x 18ℓ	Polished round 12
Y-08D	80	37	36	71	M22 x 1.5	19	28	18	28 ^{+0.3} _{-0.1}	55	76.5	ø4 x 25ℓ	Polished round 18
Y-10D	100	37	40	83	M26 x 1.5	21	38	20	30 ^{+0.3} _{-0.1}	61	83	ø4 x 30ℓ	Polished round 20

* Knuckle pin, cotter pin and flat washer are included.

Clevis Pin/Knuckle Pin

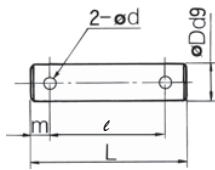

Material: Carbon steel (mm)

Part no.	Applicable bore size		Dd9	L	ℓ	m	d drill through	Applicable cotter pin	Applicable flat washer
	Clevis	Knuckle							
CDP-2A	40	—	10 ^{-0.040} _{-0.076}	46	38	4	3	ø3 x 18ℓ	Polished round 10
CDP-3A	50	40, 50, 63	12 ^{-0.050} _{-0.093}	55.5	47.5	4	3	ø3 x 18ℓ	Polished round 12
CDP-4A	63	—	16 ^{-0.050} _{-0.093}	71	61	5	4	ø4 x 25ℓ	Polished round 16
CDP-5A	—	80	18 ^{-0.050} _{-0.093}	76.5	66.5	5	4	ø4 x 25ℓ	Polished round 18
CDP-6A	80	100	20 ^{-0.065} _{-0.117}	83	73	5	4	ø4 x 30ℓ	Polished round 20
CDP-7A	100	—	25 ^{-0.065} _{-0.117}	88	78	5	4	ø4 x 36ℓ	Polished round 24

I Type Single Knuckle Joint

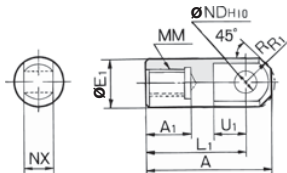

Material: Free cutting sulfur steel (mm)

Part no.	Applicable bore size (mm)	A	A1	E1	L1	MM	R1	U1	ND ^{H10}	NX
I-04A	40	69	22	24	55	M14 x 1.5	15.5	20	12 ^{+0.070} ₀	16 ^{-0.1} _{-0.3}
I-05A	50, 63	74	27	28	60	M18 x 1.5	15.5	20	12 ^{+0.070} ₀	16 ^{-0.1} _{-0.3}
I-08A	80	91	37	36	71	M22 x 1.5	22.5	26	18 ^{+0.070} ₀	28 ^{-0.1} _{-0.3}
I-10A	100	105	37	40	83	M26 x 1.5	24.5	28	20 ^{+0.084} ₀	30 ^{-0.1} _{-0.3}

Rod End Nut (Standard option)

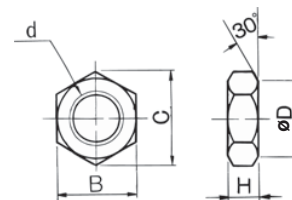

Material: Rolled steel (mm)

Part no.	Applicable bore size (mm)	d	H	B	C	D
NT-04	40	M14 x 1.5	8	22	25.4	21
NT-05	50, 63	M18 x 1.5	11	27	31.2	26
NT-08	80	M22 x 1.5	13	32	37.0	31
NT-10	100	M26 x 1.5	16	41	47.3	39

Series CA2

Minimum Auto Switch Mounting Stroke

n: Number of auto switches

Auto switch model	Number of auto switch	Brackets other than center trunnion	Center trunnion				
			ø40	ø50	ø63	ø80	ø100
D-A5□, A6□ D-F5□, J5□ D-F5□W, J59W D-F5BAL, D-F59F	2 (Different side and same side) With 1	15	90		100	110	120
	n (Same side)	$15 + 55 \frac{(n-2)}{2}$ n = 2, 4, 6, 8...	$90 + 55 \frac{(n-4)}{2}$ n = 4, 8, 12, 16...	$100 + 55 \frac{(n-4)}{2}$ n = 4, 8, 12, 16...	$110 + 55 \frac{(n-4)}{2}$ n = 4, 8, 12, 16...	$120 + 55 \frac{(n-4)}{2}$ n = 4, 8, 12, 16...	
D-A59W	2 (Different side and same side)	20	90		100	110	120
	n (Same side)	$20 + 55 \frac{(n-2)}{2}$ n = 2, 4, 6, 8...	$90 + 55 \frac{(n-4)}{2}$ n = 4, 8, 12, 16...	$100 + 55 \frac{(n-4)}{2}$ n = 4, 8, 12, 16...	$110 + 55 \frac{(n-4)}{2}$ n = 4, 8, 12, 16...	$120 + 55 \frac{(n-4)}{2}$ n = 4, 8, 12, 16...	
	1	15	90		100	110	120
D-F5LF D-F5NTL	2 (Different side and same side) With 1	25	110		120	130	140
	n (Same side)	$25 + 55 \frac{(n-2)}{2}$ n = 2, 4, 6, 8...	$110 + 55 \frac{(n-4)}{2}$ n = 4, 8, 12, 16...	$120 + 55 \frac{(n-4)}{2}$ n = 4, 8, 12, 16...	$130 + 55 \frac{(n-4)}{2}$ n = 4, 8, 12, 16...	$140 + 55 \frac{(n-4)}{2}$ n = 4, 8, 12, 16...	
D-B5□, B64 D-G5□, K59 D-G5□W D-K59W D-G5BAL D-G59F D-G5NTL	With 2	Different side	15	90		100	110
		Same side	75	90		100	110
	With n	Different side	$15 + 50 \frac{(n-2)}{2}$ n = 2, 4, 6, 8, ..	$90 + 50 \frac{(n-4)}{2}$ n = 4, 8, 12, 16, ..	$100 + 50 \frac{(n-4)}{2}$ n = 4, 8, 12, 16, ..	$100 + 50 \frac{(n-4)}{2}$ n = 4, 8, 12, 16, ..	
		Same side	$75 + 50(n-2)$ n = 2, 3, 4, ..	$90 + 50(n-2)$ n = 2, 4, 6, 8, ..	$100 + 50(n-2)$ n = 2, 4, 6, 8, ..	$110 + 50(n-2)$ n = 2, 4, 6, 8, ..	
	1	10	90		100	110	
	D-B59W	With 2	Different side	20	90		100
Same side			75	90		100	110
With n		Different side	$20 + 50 \frac{(n-2)}{2}$ n = 2, 4, 6, 8, ..	$90 + 50 \frac{(n-4)}{2}$ n = 4, 8, 12, 16, ..	$100 + 50 \frac{(n-4)}{2}$ n = 4, 8, 12, 16, ..	$100 + 50 \frac{(n-4)}{2}$ n = 4, 8, 12, 16, ..	
		Same side	$75 + 50(n-2)$ n = 2, 3, 4, ..	$90 + 50(n-2)$ n = 2, 4, 6, 8, ..	$100 + 50(n-2)$ n = 2, 4, 6, 8, ..	$110 + 50(n-2)$ n = 2, 4, 6, 8, ..	
1		15	90		100	110	
D-A3□ D-G39 D-K39		With 2	Different side	35	75		80
	Same side		100	100		100	100
	With n	Different side	$35 + 30(n-2)$ n = 2, 3, 4, ..	$75 + 30(n-2)$ n = 2, 4, 6, 8, ..	$80 + 30(n-2)$ n = 2, 4, 6, 8, ..	$90 + 30(n-2)$ n = 2, 4, 6, 8, ..	
		Same side	$100 + 100(n-2)$ n = 2, 3, 4, ..	$100 + 100(n-2), n = 2, 4, 6, 8, ..$			
	1	10	75		80	90	
	D-A44	With 2	Different side	35	75		80
Same side			55	75		80	90
With n		Different side	$35 + 30(n-2)$ n = 2, 3, 4, ..	$75 + 30(n-2)$ n = 2, 4, 6, 8, ..	$80 + 30(n-2)$ n = 2, 4, 6, 8, ..	$90 + 30(n-2)$ n = 2, 4, 6, 8, ..	
		Same side	$55 + 50(n-2)$ n = 2, 3, 4, ..	$75 + 50(n-2)$ n = 2, 4, 6, 8, ..	$80 + 50(n-2)$ n = 2, 4, 6, 8, ..	$90 + 50(n-2)$ n = 2, 4, 6, 8, ..	
1		10	75		80	90	
D-A3□C D-G39C D-K39C		With 2	Different side	20	75		80
	Same side		100	100		100	100
	With n	Different side	$20 + 35(n-2)$ n = 2, 3, 4, ..	$75 + 30(n-2)$ n = 2, 4, 6, 8, ..	$80 + 35(n-2)$ n = 2, 4, 6, 8, ..	$90 + 35(n-2)$ n = 2, 4, 6, 8, ..	
		Same side	$100 + 100(n-2)$ n = 2, 3, 4, 5, ..	$100 + 100(n-2), n = 2, 4, 6, 8, ..$			
	1	10	75		80	90	
	D-A44C	With 2	Different side	20	75		80
Same side			55	75		80	90
With n		Different side	$20 + 35(n-2)$ n = 2, 3, 4, ..	$75 + 35(n-2)$ n = 2, 4, 6, 8, ..	$80 + 35(n-2)$ n = 2, 4, 6, 8, ..	$90 + 35(n-2)$ n = 2, 4, 6, 8, ..	
		Same side	$55 + 50(n-2)$ n = 2, 3, 4, ..	$75 + 50(n-2)$ n = 2, 4, 6, 8, ..	$80 + 50(n-2)$ n = 2, 4, 6, 8, ..	$90 + 50(n-2)$ n = 2, 4, 6, 8, ..	
1		10	75		80	90	
D-Z7□, Z80 D-Y59, Y7P D-Y7□W		2 (Different side and same side) With 1	15	80	85	90	95
	n	$15 + 40 \frac{(n-2)}{2}$ n = 2, 4, 6, 8...	$80 + 40 \frac{(n-4)}{2}$ n = 4, 8, 12, 16...	$85 + 40 \frac{(n-4)}{2}$ n = 4, 8, 12, 16...	$90 + 40 \frac{(n-4)}{2}$ n = 4, 8, 12, 16...	$95 + 40 \frac{(n-4)}{2}$ n = 4, 8, 12, 16...	$105 + 40 \frac{(n-4)}{2}$ n = 4, 8, 12, 16...
D-Y69□, Y7PV D-Y7□WV	2 (Different side and same side) With 1	10	65		75	80	90
	n	$10 + 30 \frac{(n-2)}{2}$ n = 2, 4, 6, 8...	$65 + 30 \frac{(n-4)}{2}$ n = 4, 8, 12, 16...	$75 + 30 \frac{(n-4)}{2}$ n = 4, 8, 12, 16...	$80 + 30 \frac{(n-4)}{2}$ n = 4, 8, 12, 16...	$90 + 30 \frac{(n-4)}{2}$ n = 4, 8, 12, 16...	
D-Y7BAL	2 (Different side and same side) With 1	20	95		100	105	110
	n	$20 + 45 \frac{(n-2)}{2}$ n = 2, 4, 6, 8...	$95 + 45 \frac{(n-4)}{2}$ n = 4, 8, 12, 16...	$100 + 45 \frac{(n-4)}{2}$ n = 4, 8, 12, 16...	$105 + 45 \frac{(n-4)}{2}$ n = 4, 8, 12, 16...	$110 + 45 \frac{(n-4)}{2}$ n = 4, 8, 12, 16...	
D-P5DWL	2 (Different side and same side) With 1	15	120		130	140	
	n	$15 + 65 \frac{(n-2)}{2}$ n = 2, 4, 6, 8...	$120 + 65 \frac{(n-4)}{2}$ n = 4, 8, 12, 16...	$130 + 65 \frac{(n-4)}{2}$ n = 4, 8, 12, 16...	$140 + 65 \frac{(n-4)}{2}$ n = 4, 8, 12, 16...		

Air Cylinder/Standard: Double Acting Single Rod *Series CA2*

Standard type
CA2

Standard type
CA2W

Standard/Non-rotating rod
CA2K

Standard/Non-rotating rod
CA2KW

Low friction
CA2□Q

End lock
CBA2

Air-hydro
CA2□H

Air-hydro
CA2W□H

Auto switch

Made to order

Precautions

14

Proper Auto Switch Mounting Position (for stroke end detection) and Mounting Height

<Band mount type>

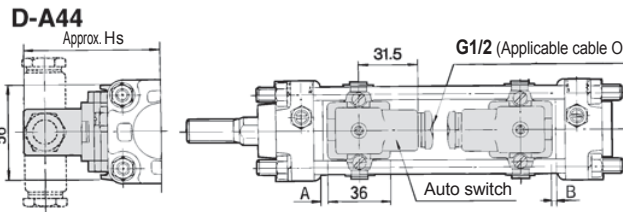
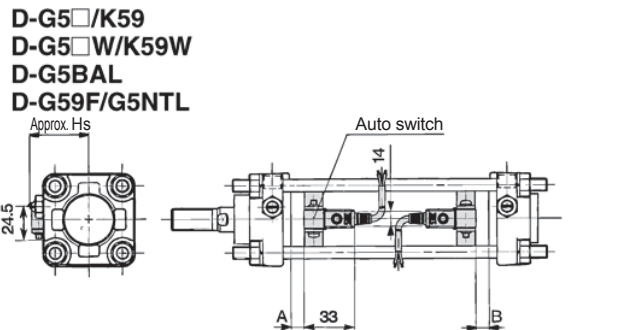
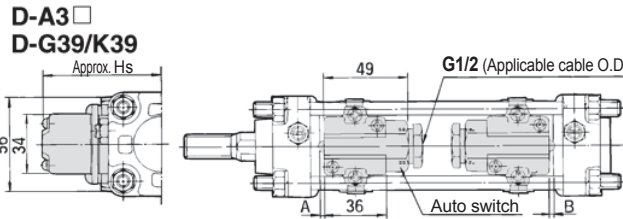
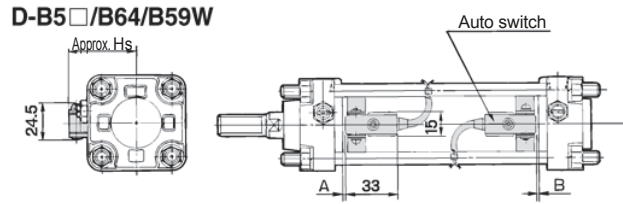

<Tie-rod mount type>

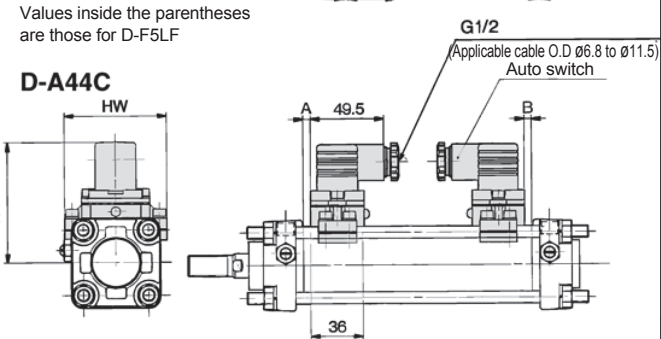
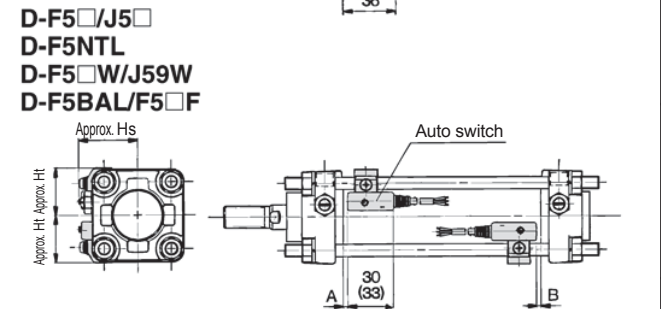
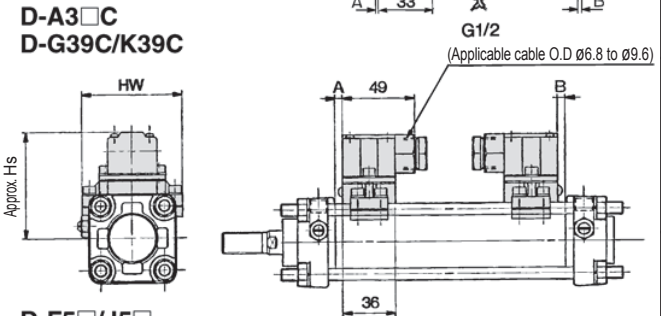
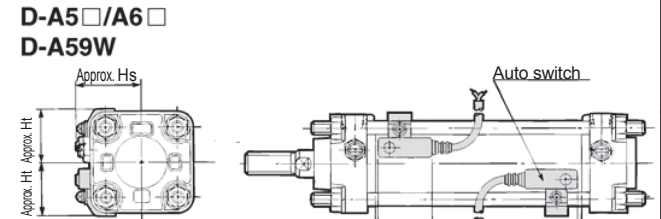

Values inside the parentheses are those for D-F5LF

Proper Auto Switch Mounting Position

Auto switch model	D-A5□, A6□		D-B5□, D-B64		D-B59W		D-F5□, D-F5□W		D-G5□, D-G5NTL		D-A59W		D-F5LF		D-F5NTL	
	A	B	A	B	A	B	A	B	A	B	A	B	A	B	A	B
40	0	0	0.5	0	3.5	1.5	6.5	4.5	2	0	4	2	10.5	8.5	11.5	9.5
50	0	0	0.5	0	3.5	1.5	6.5	4.5	2	0	4	2	10.5	8.5	11.5	9.5
63	2.5	1.5	3	2	6	5	9	8	4.5	3.5	6.5	5.5	13	12	14	13
80	6	4	6.5	4.5	9.5	7.5	4.5	12.5	8	6	10	8	16.5	14.5	17.5	15.5
100	7.5	6.5	8	7	11	10	14	13	9.5	8.5	11.5	10.5	18	17	19	18

Auto Switch Mounting Height

Auto switch model	D-B5□, B64, D-B59W		D-A3□, D-G39, D-K39		D-A44		D-A5□, D-A6□, D-A59W		D-F5□, D-J59, D-F5□W, D-J59W		D-A3□C, D-G39C, D-K39C		D-A44C	
	Hs	Ht	Hs	Ht	Hs	Ht	Hs	Ht	Hs	Ht	Hs	Hw	Hs	Hw
40	37	71.5	81.5	38.5	31.5	38	31.5	73	69	81	69			
50	42	76.5	86.5	42	35.5	42	35.5	78.5	77	86.5	77			
63	49	83.5	93.5	46.5	43	47	43	85.5	91	93.5	91			
80	57.5	92	102	53.5	51	53.5	51	94	107	102	107			
100	68	102.5	112.5	61.5	57.5	61	57.5	104	121	112	121			

Series CA2

Proper Auto Switch Mounting Position (for stroke end detection) and Mounting Height

<Tie-rod mount type>

D-Z7□/Z80
 D-Y59□/Y69□/Y7P/Y7PV
 D-Y7□W/Y7□WV
 D-Y7BAL

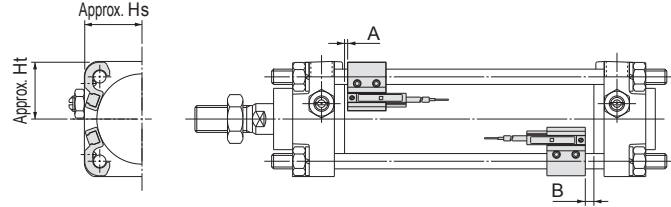

D-P5DWL

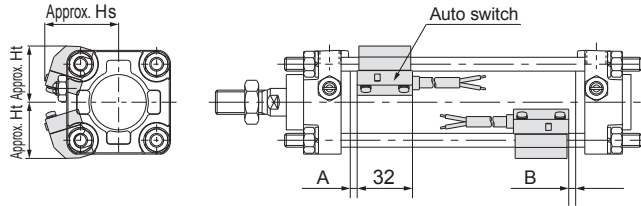

Proper Auto Switch Mounting Position (mm)

Auto switch model	D-Z7□, Z80 D-Y59□, Y69□ D-Y7P, Y7PV D-Y7□W D-Y7□WV D-Y7BAL		D-P5DWL	
	A	B	A	B
Bore size (mm) 40	3.5	1.5	3	1
50	3.5	1.5	3	1
63	6	5	5.5	4
80	9.5	7.5	9	7
100	11	10	10.5	9

Auto Switch Mounting Height (mm)

Auto switch model	D-Z7□ D-Z80 D-Y59□ D-Y7P D-Y7BAL D-Y7□W		D-Y69□ D-Y7PV D-Y7□WV		D-P5DWL	
	Hs	Ht	Hs	Ht	Hs	Ht
Bore size (mm) 40	30	30	30	30	42.5	33
50	34	34	34	34	46.5	37.5
63	41	41	41	41	52	43
80	49.5	49	49.5	49	58.5	51.5
100	56.5	55.5	57.5	55.5	66	58.5

Operating Range

Auto switch model	Bore size (mm)				
	40	50	63	80	100
D-Z7□, Z80	8.5	7.5	9.5	9.5	10.5
D-A3□, A44, A3□C, A44C	9	10	11	11	11
D-A5□, A6□					
D-B5□, B64	13	13	14	14	15
D-A59W					
D-B59W	14	14	17	16	18
D-Y59□, Y69□, Y7P, Y7□V, Y7□W, Y7□WV	8	7	5.5	6.5	6.5
D-Y7BAL	3.5	3.5	5	5	5
D-F5□, J5□, F5□W, J59W, F5BAL, F5NTL	4	4	4.5	4.5	4.5
D-F59F	5.5	5	5.5	5.5	5.5
D-G5□, K59, G5□W, K59W, G5BAL, G5NTL, G59F	5	6	6.5	6.5	7
D-G39, K39, G39C, K39C	9	9	10	10	11
D-P5DWL	4	4	4.5	4	4.5

* The above operating ranges are provided as guidelines including the hysteresis and are not guaranteed values (with approx. ±30% variations). They may vary significantly with the surrounding environment.

Besides the models listed in "How to Order," the following auto switches are applicable.

Refer to page 5.3 of Best Pneumatics ② for detailed auto switch specifications.

Auto switch type	Mounting	Part No.	Electrical entry	Features
Reed	Tie-rod	D-A53, A56	Grommet (in-line)	—
		D-A64, A67		Without indicator light
		D-Z80		—
	Band	D-A33C, A34C	Terminal conduit	—
		D-A44C	DIN terminal	—
		D-B53, B54	Grommet (in-line)	—
Solid state	Tie-rod	D-F59, F5P, J59	Grommet (in-line)	—
		D-F59W, F5PW, J59W		2-colour indication
	Band	D-F5BAL	Grommet (in-line)	Water resistant (2-colour indication)
		D-F5NTL		With timer
Solid state	Tie-rod	D-Y69A, Y7PV, Y69B	Terminal conduit	—
		D-Y7NW, Y7PW, Y7BW		2-colour indication
		D-G39C, K39C		—
	Band	D-G59, G5P, K59	Grommet (in-line)	—
		D-G59W, G5PW, K59W		2-colour indication
		D-G5BAL		Water resistant (2-colour indication)
Solid state	Band	D-G59F	Terminal conduit	Latch type with diagnostic output (2-colour indication)
		D-G5NTL		With timer
		D-G39, K39		—

* Solid state switches are also available with pre-wired connector. Contact SMC for detailed auto switch specifications.

* The normally closed type (NC = b contact) of solid state auto switch (D-Y7G, Y7H) are also available. Contact SMC for detailed auto switch specifications.

Air Cylinder/Double Acting Double Rod

Series CA2W

ø40, ø50, ø63, ø80, ø100

How to Order

Without auto switch CA2W L [] 50 [] 100 JJ

With auto switch CDA2W L [] 50 [] 100 JJ Y7BW []

Mounting

B	Basic
L	Axial foot
F	Front flange
T	Centre trunnion

Tube material

Nil	Aluminum tube
F*	Steel tube

* Not available with auto switch.

Bore size

40	40 mm
50	50 mm
63	63 mm
80	80 mm
100	100 mm

Port thread type

Nil	Rc
TN	NPT
TF	G

Cylinder stroke (mm)

For more information, please refer to the next page.

Number of auto switches

Nil	2 pcs.
S	1 pc.
3	3 pcs.
n	"n" pcs.

Auto switch

Nil	Without auto switch
-----	---------------------

* Select an applicable auto switch model from the table below.
* D-Z7□, Z80, Y59□, Y69□, and Y7□ are not mounted and are supplied loose at the time of shipment. (Only the switch mounting brackets for these models are mounted.)

Cylinder suffix

One end rod boot	Nil	Without rod boot
	J	Nylon tarpaulin
	K	Heat resistant tarpaulin
Both ends rod boot	Nil	Without rod boot
	JJ	Nylon tarpaulin
	KK	Heat resistant tarpaulin
Cushion	Nil	With cushion on both sides
	N	Without cushion

* When more than one symbol is to be specified, indicate them in alphabetical order.

Applicable Auto Switch : Refer to page 5.3 of Best Pneumatics ② for detailed auto switch specifications.

Type	Special function	Electrical entry	Indicator light	Wiring (output)	Load voltage		Auto switch model	Lead wire length (m)*			Pre-wired connector	Applicable load		
					DC	AC		0.5 (Nil)	3 (L)	5 (Z)				
Reed switch	—	Grommet	Yes	3-wire (NPN equiv.)	—	5 V	—	Z76	●	●	—	—	IC circuit	—
				2-wire	24 V	12 V	100 V	Z73	●	●	●	—	—	Relay, PLC
	Diagnostic indication (2-colour indication)	Grommet	—	—	—	A59W	●	●	●	—	—	—		
Solid state switch	—	Grommet	Yes	3-wire (NPN)	24 V	5 V, 12 V	—	Y59A	●	●	○	○	IC circuit	Relay, PLC
				3-wire (PNP)				Y7P	●	●	○	○		
				2-wire	—	—	100 V, 200 V	J51	●	●	○	○	—	
	Diagnostic indication (2-colour indication)	Grommet	Yes	3-wire (NPN)	24 V	5 V, 12 V	—	Y59B	●	●	○	○	IC circuit	
				3-wire (PNP)				Y7NW	●	●	○	○		
				2-wire	—	—	—	Y7PW	●	●	○	○	—	
	Water resistant (2-colour indication)	Grommet	Yes	2-wire	24 V	12 V	—	Y7BW	●	●	○	○	—	
	With diagnostic output (2-colour indication)			Y7BA				—	●	○	○			
	Latch type with diagnostic output (2-colour indication)	Grommet	Yes	4-wire (NPN)	24 V	5 V, 12 V	—	F59F	●	●	○	○	IC circuit	
	Magnetic field resistant (2-colour indication)			2-wire				—	—	—	F5LF	●	●	

* Lead wire length symbol 0.5 m.....Nil (Example) A54
3 m.....L (Example) A54L
5 m.....Z (Example) A54Z

* Solid state switches marked with "○" are produced upon receipt of order.

• In addition to the models in the above table, there are some other auto switches that are applicable. For more information, refer to page 15.

Standard type
CA2

Standard type
CA2W

Standard/Non-rotating rod
CA2K

Standard/Non-rotating rod
CA2KW

Low friction
CA2□Q

End lock
CBA2

Air-hydro
CA2□H

Air-hydro
CA2W□H

Auto switch

Made to order

Precautions

Series CA2W

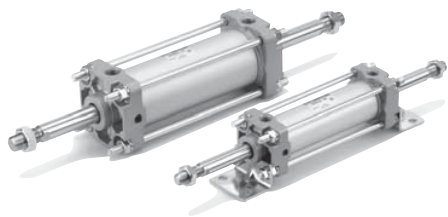

JIS symbol

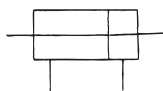

Made to Order Specifications
For more information, please refer to page 64.

Symbol	Specifications/Contents
-XA□	Change of rod end shape
-XB6	Heat resistant (150°C)
-XC3	Special port positions
-XC4	With heavy duty scraper
-XC5	Heat resistant (110°C)
-XC6	Piston rod and rod end nut made of stainless steel
-XC7	Tie-rod, cushion valve, and tie-rod nut and similar parts made of stainless steel
-XC14	Change of trunnion bracket mounting position
-XC15	Change of tie-rod length
-XC22	Fluoro rubber seal
-XC27	Double clevis pin and double knuckle pin made of stainless steel
-XC28	Compact flange made of SS400
-XC35	With coil scraper

Minimum stroke for auto switch mounting

⚠ Caution

- ① The minimum stroke for mounting varies with the auto switch type and mounting type of the cylinder.
In particular, the center trunnion type needs careful attention.
(For more information, please refer to page 13.)

Specifications

Fluid	Air
Action	Double acting
Proof pressure	1.5 MPa
Maximum operating pressure	1.0 MPa
Minimum operating pressure	0.08MPa
Piston speed	50 to 500 mm/s*
Ambient and fluid temperature	Without auto switch: -10 to 70°C* With auto switch: -10 to 60°C*
Cushion	Air cushion
Thread tolerance	JIS class 2
Stroke length tolerance	to 250 st : ^{+1.0} / ₀ 251 to 750 st : ^{+1.4} / ₀
Lubrication	Not required (Non-lube)
Mounting	Basic, Axial foot, Front flange, Centre trunnion

* With no freezing. * Operate within the range of absorbing kinetic energy. (Refer to page 3.)

Standard Stroke/ In case of a type with auto switch, please also refer to the table of minimum strokes for auto switch mounting on page 13.

Bore size (mm)	Standard stroke (mm)
40	25, 50, 75, 100, 125, 150, 175, 200, 250, 300, 350, 400, 450, 500
50, 63	25, 50, 75, 100, 125, 150, 175, 200, 250, 300, 350, 400, 450, 500, 600
80, 100	25, 50, 75, 100, 125, 150, 175, 200, 250, 300, 350, 400, 450, 500, 600, 700

* Intermediate strokes not listed above are produced upon receipt of order.

Rod Boot Material

Symbol	Rod boot material	Max. ambient temperature
J	Nylon tarpaulin	70°C
K	Heat resistant tarpaulin	110°C*

* Maximum ambient temperature for the rod boot itself.

Accessory

Mounting		Basic	Foot	Flange	Center trunnion
Standard equipment	Rod end nut	●	●	●	●
Options	Single knuckle joint	●	●	●	●
	Double knuckle joint (with pin)	●	●	●	●
	With rod boot	●	●	●	●

* The above brackets have the same dimensions as those for the standard double acting single rod Series CA2. Please refer to page 12.

Weight/Aluminum Tube (Steel tube)

Bore size (mm)		40	50	63	80	100	
Basic weight	Basic	Aluminum tube	0.99	1.51	2.10	3.56	4.88
		Steel tube	1.05	1.58	2.18	3.76	5.16
	Axial foot	Aluminum tube	1.18	1.73	2.43	4.23	5.87
		Steel tube	1.24	1.80	2.51	4.43	6.15
	Flange	Aluminum tube	1.36	1.96	2.89	5.01	6.80
		Steel tube	1.42	2.03	2.97	5.21	7.08
	Trunnion	Aluminum tube	1.35	1.99	2.90	5.11	7.16
		Steel tube	1.41	2.06	2.98	5.31	7.44
Additional weight by each 50 mm stroke	All mounting brackets	Aluminum tube	0.28	0.37	0.44	0.66	0.86
		Steel tube	0.35	0.47	0.55	0.89	1.15
Accessories	Single knuckle	0.23	0.26	0.26	0.60	0.83	
	Double knuckle (with pin)	0.37	0.43	0.43	0.87	1.27	

Calculation example: CA2WL40-100 (axial foot type, ø40, 100st)

- Basic weight ... 1.18 (axial foot, ø40)
 - Additional weight ... 0.28/50st
 - Cylinder stroke ... 100st
- $$1.18 + 0.28 \times 100/50 = 1.74 \text{ kg}$$

The minimum stroke for auto switch mounting, proper auto switch mounting position and height, operating range, applicable auto switches, auto switch mounting brackets and their part numbers, and bracket part numbers are the same as those for the double acting single rod type of Series CA2.

Copper Free

20-CA2W Mounting Bore size Stroke Suffix

- Copper free

This cylinder eliminates any influences of copper ions or fluororesin on colour CRTs. Copper materials have been nickel plated or replaced with non-copper materials to prevent the generation of copper ions.

Specifications

Action	Double acting double rod
Bore size	ø40, ø50, ø63, ø80, ø100
Maximum operating pressure	1.0 MPa
Minimum operating pressure	0.08 MPa
Cushion	Air cushion
Piping	Screw-in piping
Piston speed	50 to 500 mm/s*
Mounting	Basic, Axial foot, Front flange, Centre trunnion

* Auto switch capable
* Operate within the range of absorbed energy. (Refer to page 3.)

Construction

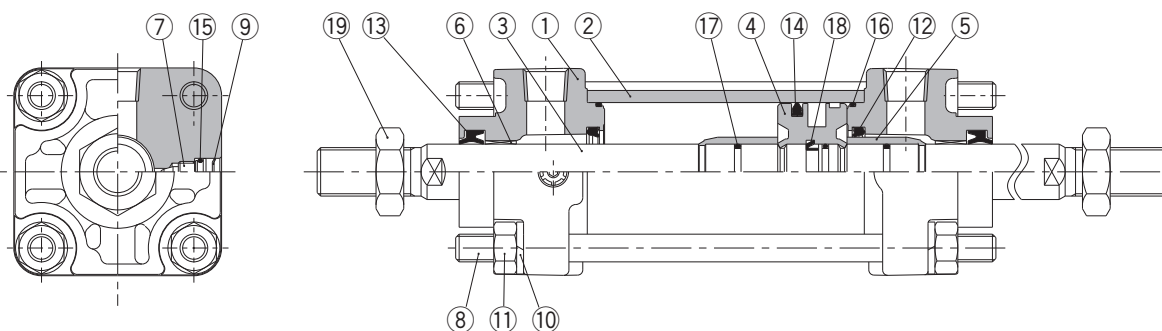

Parts List

No.	Description	Material	Note
1	Rod cover	Die-cast aluminum	Metallic painted
2	Cylinder tube	Aluminum alloy	Hard anodized
3	Piston rod	Carbon steel	Hard chromium electroplated
4	Piston	Aluminum alloy	Chromated
5	Cushion ring	Brass	
6	Bushing	Lead-bronze casting	
7	Cushion valve	Steel wire	Nickel plated
8	Tie-rod	Carbon steel	Corrosion resistant chromated
9	Snap ring	Spring steel	
10	Spring washer	Rolled steel	Chromated
11	Tie-rod nut	Rolled steel	Nickel plated
12	Cushion seal	Urethane	
13	Rod seal	NBR	
14	Piston seal	NBR	
15	Cushion valve seal	NBR	O-ring
16	Cylinder tube gasket	NBR	
17	Piston gasket	NBR	
18	Piston holder	Urethane	
19	Rod end nut	Rolled steel	Nickel plated

Replacement Parts: Seal Kits

Bore size (mm)	Seal kit No.	Content
	Air cylinder	
40	MBW40-PS	Consists of numbers 12, 13, 14, and 16 above.
50	MBW50-PS	
63	MBW63-PS	
80	MBW80-PS	
100	MBW100-PS	

Series CA2W

Basic/CA2WB

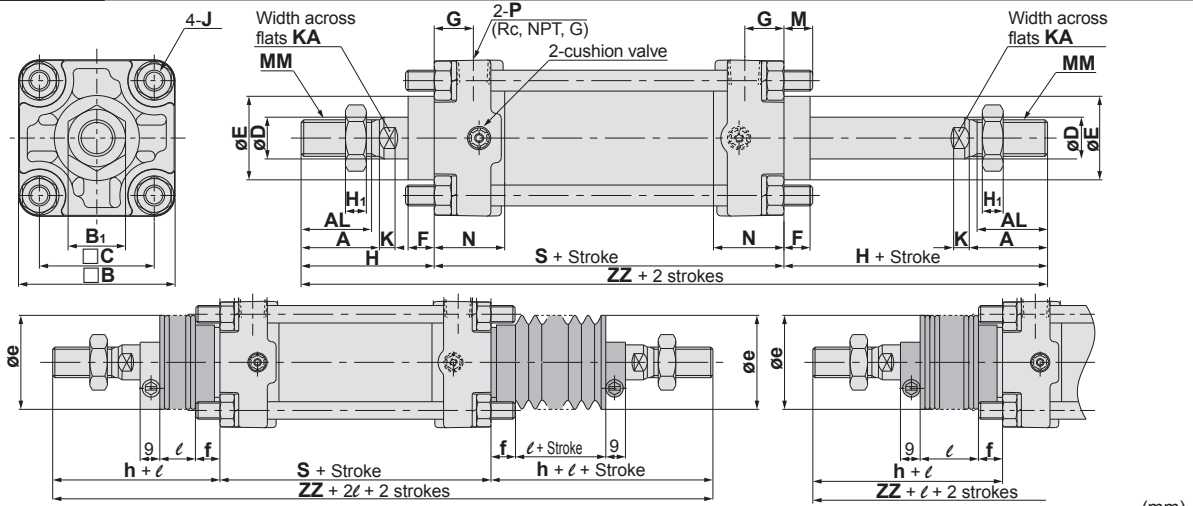

Bore size (mm)	Stroke range (mm)		A	AL	□B	B ₁	□C	D	E	F	G	H ₁	J	K	KA	M	MM	N
	Without rod boot	With rod boot																
40	up to 500	20 to 500	30	27	60	22	44	16	32	10	15	8	M8	6	14	11	M14 x 1.5	27
50	up to 600	20 to 600	35	32	70	27	52	20	40	10	17	11	M8	7	18	11	M18 x 1.5	30
63	up to 600	20 to 600	35	32	85	27	64	20	40	10	17	11	M10 x 1.25	7	18	14	M18 x 1.5	31
80	up to 750	20 to 750	40	37	102	32	78	25	52	14	21	13	M12	10	22	17	M22 x 1.5	37
100	up to 750	20 to 750	40	37	116	41	92	30	52	14	21	16	M12	10	26	17	M26 x 1.5	40

Bore size (mm)	P	S	Without rod boot		With rod boot (Single side)					(Both sides)	
			H	ZZ	e	f	h	ℓ	ZZ	ZZ	
40	1/4	84	51	186	43	11.2	59	1/4 stroke	194	202	
50	3/8	90	58	206	52	11.2	66	1/4 stroke	214	222	
63	3/8	98	58	214	52	11.2	66	1/4 stroke	222	230	
80	1/2	116	71	258	65	12.5	80	1/4 stroke	267	276	
100	1/2	126	72	270	65	14.0	81	1/4 stroke	279	288	

Axial Foot/CA2WL

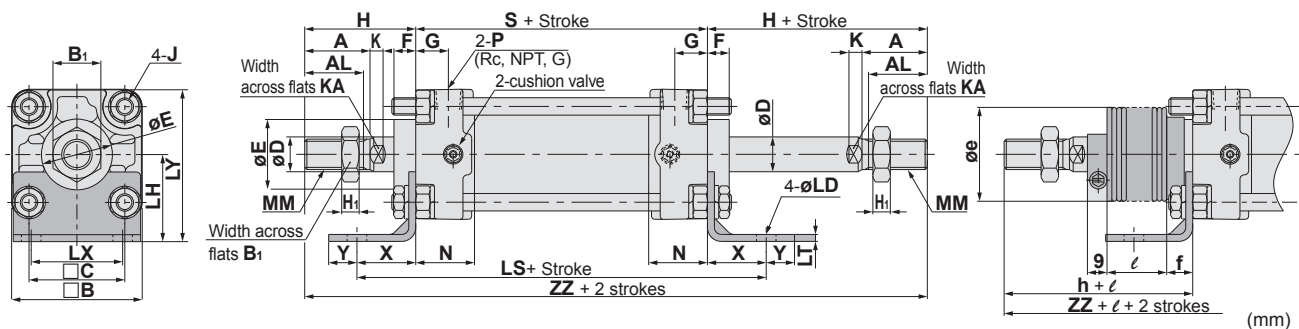

Bore size (mm)	Stroke range (mm)		A	AL	□B	B ₁	□C	D	E	F	G	H ₁	J	K	KA	LD	LH	LS	LT
	Without rod boot	With rod boot																	
40	up to 500	20 to 500	30	27	60	22	44	16	32	10	15	8	M8	6	14	9	40	138	3.2
50	up to 600	20 to 600	35	32	70	27	52	20	40	10	17	11	M8	7	18	9	45	144	3.2
63	up to 600	20 to 600	35	32	85	27	64	20	40	10	17	11	M10 x 1.25	7	18	11.5	50	166	3.2
80	up to 750	20 to 750	40	37	102	32	78	25	52	14	21	13	M12	10	22	13.5	65	204	4.5
100	up to 750	20 to 750	40	37	116	41	92	30	52	14	21	16	M12	10	26	13.5	75	212	6.0

Bore size (mm)	LX	LY	MM	N	P	S	X	Y	Without rod boot		With rod boot (Single side)					(Both sides)	
									H	ZZ	e	f	h	ℓ	ZZ	ZZ	
40	42	70	M14 x 1.5	27	1/4	84	27	13	51	186	43	11.2	59	1/4 stroke	194	202	
50	50	80	M18 x 1.5	30	3/8	90	27	13	58	206	52	11.2	66	1/4 stroke	214	222	
63	59	93	M18 x 1.5	31	3/8	98	34	16	58	214	52	11.2	66	1/4 stroke	222	230	
80	76	116	M22 x 1.5	37	1/2	116	44	16	71	258	65	12.5	80	1/4 stroke	267	276	
100	92	133	M26 x 1.5	40	1/2	126	43	17	72	270	65	14.0	81	1/4 stroke	279	288	

Air Cylinder/Double Acting Double Rod **Series CA2W**

Standard type
CA2

Standard type
CA2W

Standard/Non-rotating rod
CA2K

Standard/Non-rotating rod
CA2KW

Low friction
CA2□Q

End lock
CBA2

Air-hydro
CA2□H

Air-hydro
CA2W□H

Auto switch

Made to order

Precautions

Front Flange/CA2WF

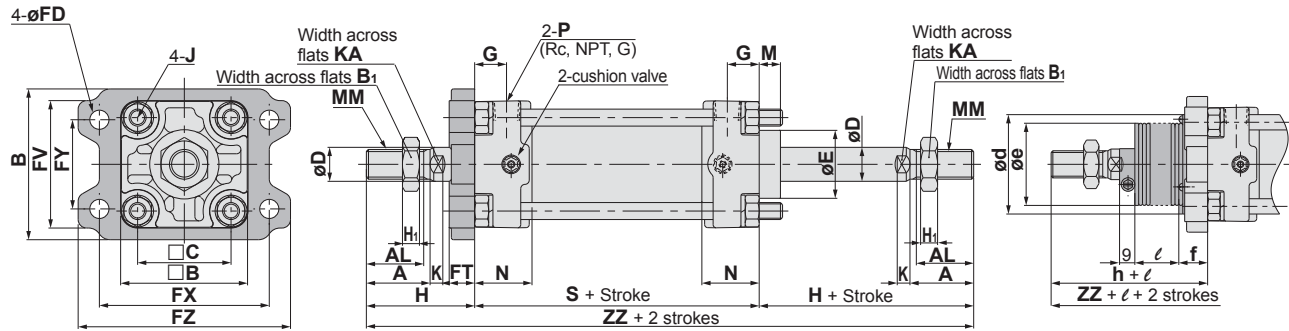

(mm)

Bore size (mm)	Stroke range (mm)		A	AL	B	□B	B ₁	□C	D	E	FD	FT	FX	FY	FZ	FV	G	H ₁	J	K
	Without rod boot	With rod boot																		
40	up to 500	20 to 500	30	27	71	60	22	44	16	32	9.0	12	80	42	100	60	15	8	M8	6
50	up to 600	20 to 600	35	32	81	70	27	52	20	40	9.0	12	90	50	110	70	17	11	M8	7
63	up to 600	20 to 600	35	32	101	85	27	64	20	40	11.5	15	105	59	130	86	17	11	M10 x 1.25	7
80	up to 750	20 to 750	40	37	119	102	32	78	25	52	13.5	18	130	76	160	102	21	13	M12	10
100	up to 750	20 to 750	40	37	133	116	41	92	30	52	13.5	18	150	92	180	116	21	16	M12	10

Bore size (mm)	KA	M	MM	N	P	S	Without rod boot		With rod boot (Single side)							(Both sides)	
							H	ZZ	d*	e	f	h	ℓ	ZZ	ZZ		
40	14	11	M14 x 1.5	27	1/4	84	51	186	52	43	15	59	1/4 stroke	194	202		
50	18	11	M18 x 1.5	30	3/8	90	58	206	58	52	15	66	1/4 stroke	214	222		
63	18	14	M18 x 1.5	31	3/8	98	58	214	58	52	17.5	66	1/4 stroke	222	230		
80	22	17	M22 x 1.5	37	1/2	116	71	258	80	65	21.5	80	1/4 stroke	267	276		
100	26	17	M26 x 1.5	40	1/2	126	72	270	80	65	21.5	81	1/4 stroke	279	288		

* If a hole is provided to accommodate the boot when the air cylinder is mounted, make the hole diameter larger than the outside diameter of the boot ød.

Center Trunnion/CA2WT

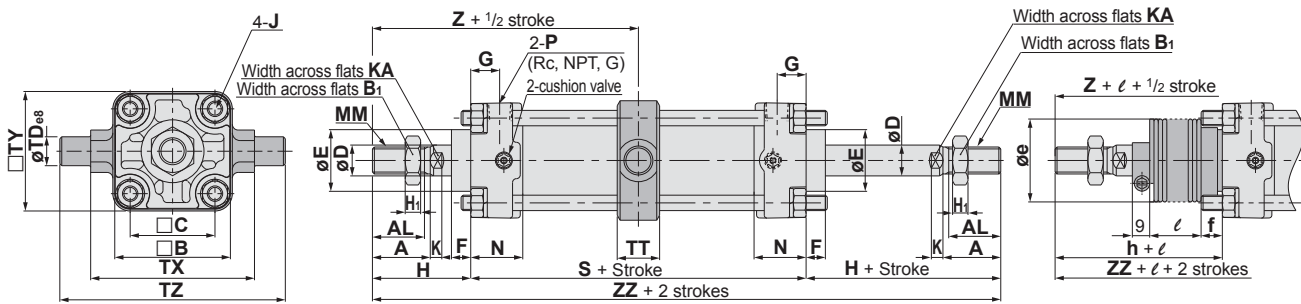

(mm)

Bore size (mm)	Stroke range (mm)		A	AL	□B	B ₁	□C	D	E	F	G	J	K	MM	N	P	S
	Without rod boot	With rod boot															
40	up to 500	20 to 500	30	27	60	22	44	16	32	10	15	M8 x 1.25	6	M14 x 1.5	27	1/4	84
50	up to 600	20 to 600	35	32	70	27	52	20	40	10	17	M8 x 1.25	7	M18 x 1.5	30	3/8	90
63	up to 600	20 to 600	35	32	85	27	64	20	40	10	17	M10 x 1.25	7	M18 x 1.5	31	3/8	98
80	up to 750	20 to 750	40	37	102	32	78	25	52	14	21	M12 x 1.75	10	M22 x 1.5	37	1/2	116
100	up to 750	20 to 750	40	37	116	41	92	30	52	14	21	M12 x 1.75	10	M26 x 1.5	40	1/2	126

Bore size (mm)	TDe8	TT	TX	TY	TZ	Without rod boot		With rod boot (Single side)							(Both sides)	
						H	Z	ZZ	e	f	h	ℓ	Z	ZZ	Z	ZZ
40	15 ^{-0.032} _{-0.059}	22	85	62	117	51	93	186	43	11.2	59	1/4 stroke	101	194	101	202
50	15 ^{-0.032} _{-0.059}	22	95	74	127	58	103	206	52	11.2	66	1/4 stroke	111	214	111	222
63	18 ^{-0.032} _{-0.059}	28	110	90	148	58	107	214	52	11.2	66	1/4 stroke	115	222	115	230
80	25 ^{-0.040} _{-0.073}	34	140	110	192	71	129	258	65	12.5	80	1/4 stroke	138	267	138	276
100	25 ^{-0.040} _{-0.073}	40	162	130	214	72	135	270	65	14.0	81	1/4 stroke	144	279	144	288

Air Cylinder /Double Acting: Non-rotating Rod

Series CA2K

ø40, ø50, ø63

How to Order

Without auto switch

CA2K L 40 [] 200 []

With auto switch

CDA2K L 40 [] 200 [] Y7BW []

With auto switch

Non-rotating rod
Mounting

B	Basic
L	Axial foot
F	Front flange
G	Rear flange
C	Single clevis
D	Double clevis
T	Centre trunnion

Bore size

40	40 mm
50	50 mm
63	63 mm

Port thread type

Nil	Rc
TN	NPT
TF	G

Number of auto switches

Nil	2 pcs.
S	1 pc.
3	3 pcs.
n	"n" pcs.

Auto switch

Nil	Without auto switch
-----	---------------------

* Select an applicable auto switch model from the table below.

* D-Z7□, Z80, Y59□, Y69□, and Y7□ are not mounted and are supplied loose. (Only the switch mounting brackets for these models are mounted.)

Cylinder suffix

Rod boot	Nil	Without
	J	Nylon tarpaulin
	K	Heat resistant tarpaulin
Cushion	Nil	Cushion at both ends
	N	Without cushion

* When more than one symbol is to be specified, indicate them in alphabetical order.

Cylinders with built-in magnets

If built-in magnet type is ordered without auto switch, leave the field for the auto switch type blank.
(Example) CDA2KL40-100

Cylinder stroke (mm)

For more information, please refer to the next page.

Applicable Auto Switch : Refer to page 5.3 of Best Pneumatics ② for detailed auto switch specifications.

Type	Special function	Electrical entry	Indicator/light	Wiring (output)	Load voltage		Auto switch model	Lead wire length (m)*			Pre-wired connector	Applicable load					
					DC	AC		0.5 (Nil)	3 (L)	5 (Z)							
Reed switch	—	Grommet	Yes	3-wire (NPN equiv.)	—	5 V	—	Z76	●	●	—	—	IC circuit	—			
				2-wire	24 V	12 V	100 V	Z73	●	●	●	—	—	Relay, PLC			
						—	100 V, 200 V	A54	●	●	●	—					
Diagnostic indication (2-colour indication)	Grommet	—	—	—	—	A59W	●	●	—	—	—						
Solid state switch	—	Grommet	Yes	3-wire (NPN)	24 V	5 V, 12 V	—	Y59A	●	●	○	○	IC circuit	Relay, PLC			
				3-wire (PNP)				Y7P	●	●	○	○					
				2-wire	—	100 V, 200 V	J51	●	●	○	—	—					
							Y59B	●	●	○	○						
				Diagnostic indication (2-colour indication)	Grommet	Yes	3-wire (NPN)	24 V	5 V, 12 V	—	Y7NW	●	●		○	○	IC circuit
							3-wire (PNP)				Y7PW	●	●		○	○	
							2-wire				Y7BW	●	●		○	○	
				Water resistant (2-colour indication)	Grommet	Yes	2-wire	24 V	12 V	—	Y7BA	—	●		○	○	—
				With diagnostic output (2-colour indication)							F59F	●	●		○	○	
				Latch type with diagnostic output (2-colour indication)	Grommet	Yes	4-wire (NPN)	24 V	5 V, 12 V	—	F5LF	●	●		○	○	—
Magnetic field resistant (2-colour indication)	2-wire	—	—	P5DW							—	●	●	○	○		

* Lead wire length symbol 0.5 m.....Nil (Example) A54
3 m.....L (Example) A54L
5 m.....Z (Example) A54Z

* Solid state switches marked with "○" are produced upon receipt of order.

• In addition to the models in the above table, there are some other auto switches that are applicable. For more information, refer to page 15.

Air Cylinder /Double Acting: Non-rotating Rod **Series CA2K**

Standard type
CA2

Standard type
CA2W

Standard/Non-rotating rod
CA2K

Standard/Non-rotating rod
CA2KW

Low friction
CA2□□

End lock
CBA2

Air-hydro
CA2□H

Air-hydro
CA2W□H

Auto switch

Made to order

Precautions

Non-rotating accuracy/±0.5°
Same mounting dimensions as
those of standard cylinder

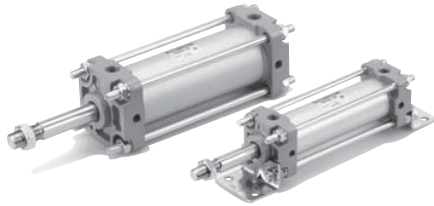

Specifications

Fluid	Air
Proof pressure	1.5 MPa
Maximum operating pressure	1.0 MPa
Minimum operating pressure	0.05 MPa
Ambient and fluid temperature	Without auto switch: -10 to 70°C*, With auto switch: -10 to 60°C
Piston speed	50 to 500 mm/s*
Cushion	Air cushion
Thread tolerance	JIS class 2
Stroke length tolerance	To 250 st : +1.0 ₀ , 251 to 600 st : +1.4 ₀
Rod non-rotating accuracy	±0.5°
Allowable rotational torque	0.44 Nm or less
Lubrication	Not required (Non-lube)
Mounting	Basic, Axial foot, Front flange, Rear flange, Single clevis, Double clevis, Centre trunnion

* With no freezing. * Operate within the range of absorbing kinetic energy. (Refer to page 3.)

Standard Stroke/ In case of a type with auto switch, please also refer to the table of minimum strokes for auto switch mounting on page 13.

Bore size (mm)	Standard stroke (mm)
40	25, 50, 75, 100, 125, 150, 175, 200, 250, 300, 350, 400, 450, 500*
50, 63	25, 50, 75, 100, 125, 150, 175, 200, 250, 300, 350, 400, 450, 500, 600*

* Intermediate strokes not listed above are also available.
Consult SMC for longer strokes than the strokes marked with*.

JIS symbol

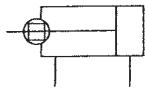

Made to Order Specifications
For more information, please refer to page 64.

JIS symbol	Specifications/Contents
-XA□	Change of rod end shape
-XC7	Tie-rod, cushion valve, and tie-rod nut and similar parts made of stainless steel
-XC8	Adjustable stroke/Extension adjustment
-XC9	Adjustable stroke/Retraction adjustment
-XC11	Dual stroke cylinder/Single rod
-XC14	Change of trunnion bracket mounting position
-XC15	Change of tie-rod length
-XC27	Double clevis pin and double knuckle pin made of stainless steel
-XC28	Compact flange made of SS400

Weight

		(kg)		
		40	50	63
Basic weight	Bore size (mm)			
	Basic	0.88	1.32	1.91
	Axial foot	1.07	1.54	2.25
	Flange	1.25	1.77	2.70
	Single clevis	1.11	1.66	2.54
	Double clevis	1.15	1.75	2.70
	Trunnion	1.24	1.80	2.71
Additional weight by each 50 mm stroke		0.20	0.25	0.30
Accessories	Single knuckle	0.23	0.26	0.26
	Double knuckle (with pin)	0.37	0.43	0.43

Calculation example: CA2KL40-100

- Basic weight.....1.07 (axial foot ø40)
- Additional weight0.20/50st
- Cylinder stroke.....100st
1.07 + 0.20 × 100/50 = 1.47 kg

Rod Boot Material

Symbol	Rod boot material	Max. ambient temperature
J	Nylon tarpaulin	70°C
K	Heat resistant tarpaulin	110°C*



* Maximum ambient temperature for the rod boot itself.

The minimum stroke for auto switch mounting, proper auto switch mounting position and height, operating range, applicable auto switches, auto switch mounting brackets and their part numbers, and bracket part numbers are the same as those for the double acting single rod type of Series CA2.

Minimum Stroke for Auto Switch Mounting

⚠ Caution

① The minimum stroke for mounting varies with the auto switch type and mounting type of the cylinder. In particular, the centre trunnion type needs careful attention. (For more information, please refer to page 13.)

Series CA2K

Copper Free

20 – CA2K Mounting Bore size Stroke Suffix

• Copper free

This cylinder eliminates any influences of copper ions or fluororesin on colour CRTs. Copper materials have been nickel plated or replaced with non-copper materials to prevent the generation of copper ions.

Specifications

Action	Double acting single rod
Bore size	ø40, ø50, ø63
Maximum operating pressure	1MPa
Minimum operating pressure	0.05MPa
Cushion	Air cushion
Piston speed	50 to 500 mm/s*
Mounting	Basic, Axial foot, Front flange, Rear flange, Single clevis, Double clevis, Centre trunnion

* Operate within the range of absorbing energy. (Refer to page 3.)
* Auto switch capable

⚠ Specific Product Precautions

Be sure to read before handling. Please refer to pages 72 to 79 for safety instructions and common precautions.

Operating Precautions

⚠ Caution

Avoid applications in which rotational torque is applied to the piston rod.

- If rotational torque is applied, the non-rotating guide will be deformed, resulting in a loss of non-rotating accuracy. Also, to screw a bracket or a nut onto the threaded portion at the end of the piston rod, make sure that the piston rod is fully retracted, and place a wrench on the parallel section of the rod that protrudes. To tighten, take precautions to prevent the tightening torque from being applied to the non-rotating guide.

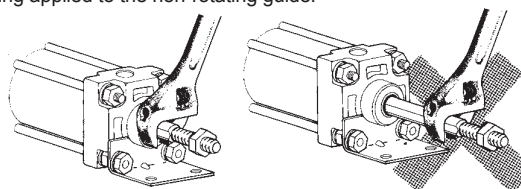

Disassembly/Replacement

- Consult SMC when the rod seal is to be replaced.**
A rod seal may allow air leakage depending on the position where it is installed. Therefore, please consult SMC when a rod seal is to be replaced.
- Do not replace the non-rotating guide.**
Since the non-rotating guide is press fitted, the entire cover assembly needs to be replaced instead of a single part.

Construction

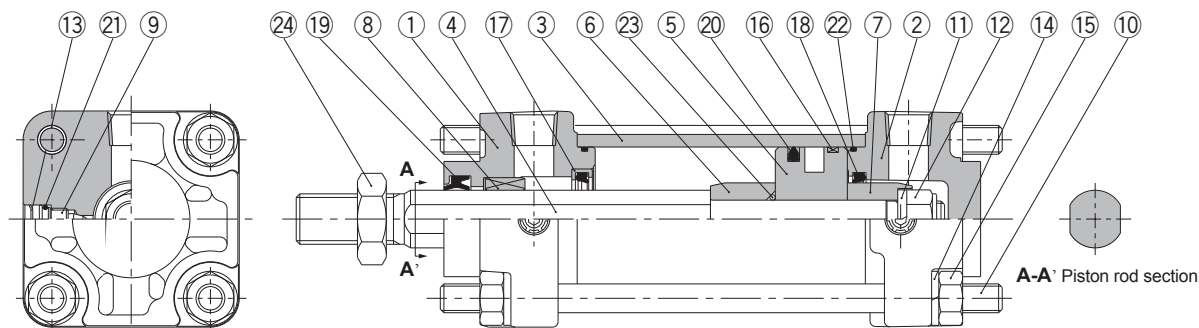

Parts List

No.	Description	Material	Note
1	Rod cover	Aluminum alloy	Metallic painted
2	Head cover	Die-cast aluminum	Metallic painted
3	Cylinder tube	Aluminum alloy	Hard anodized
4	Piston rod	Carbon steel	Hard chromium electroplated
5	Piston	Aluminum alloy	Chromated
6	Cushion ring A	Rolled steel	Zinc chromated
7	Cushion ring B	Rolled steel	Zinc chromated
8	Non-rotating guide	Sintered alloy	
9	Cushion valve	Steel wire	Nickel plated
10	Tie-rod	Carbon steel	Corrosion resistant chromated
11	Spring washer	Steel wire	Zinc chromated
12	Piston nut	Rolled steel	Zinc chromated
13	Snap ring	Spring steel	
14	Spring washer	Steel wire	Chromated
15	Tie-rod nut	Rolled steel	Zinc chromated
16	Wear ring	Resin	

No.	Description	Material	Note
17	Cushion seal holder	Aluminum alloy	
18	Cushion seal	Urethane	
19	Rod seal	NBR	
20	Piston seal	NBR	
21	Cushion valve seal	NBR	
22	Cylinder tube gasket	NBR	
23	Piston gasket	NBR	O-ring
24	Rod end nut	Rolled steel	Nickel plated

Replacement Parts

Bore size (mm)	Seal kit No.	Content
40	CA2K40-PS	Consists of numbers 18, 19, 20, and 22 above.
50	CA2K50-PS	
63	CA2K63-PS	

* The seal kits consist of items 18, 19, 20, 22. Please order them by using the seal kit number corresponding to each bore size.

Air Cylinder /Double Acting: Non-rotating Rod **Series CA2K**

Standard type
CA2

Standard type
CA2W

Standard/Non-rotating rod
CA2K

Standard/Non-rotating rod
CA2KW

Low friction
CA2□Q

End lock
CBA2

Air-hydro
CA2□H

Air-hydro
CA2W□H

Auto switch

Made to order

Precautions

Basic/CA2KB

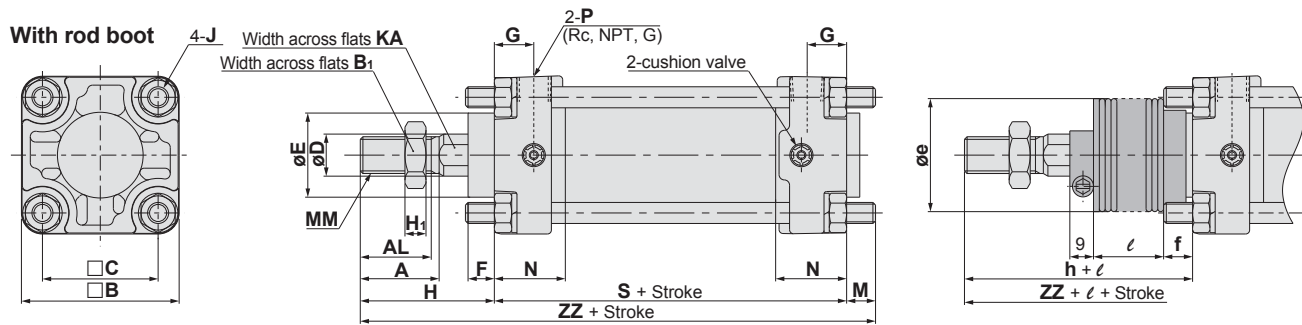

Bore size (mm)	Stroke range (mm)		A	AL	$\square B$	B ₁	$\square C$	D	E	F	G	H ₁	J	KA	M	MM
	Without rod boot	With rod boot														
40	up to 500	20 to 500	30	27	60	22	44	16	32	10	15	8	M8	14	11	M14 x 1.5
50	up to 600	20 to 600	35	32	70	27	52	20	40	10	17	11	M8	18	11	M18 x 1.5
63	up to 600	20 to 600	35	32	85	27	64	20	40	10	17	11	M10 x 1.25	18	14	M18 x 1.5

Bore size (mm)	N	P	S	Without rod boot		With rod boot				
				H	ZZ	e	f	h	ℓ	ZZ
40	27	1/4	84	51	146	43	11.2	59	1/4 stroke	154
50	30	3/8	90	58	159	52	11.2	66	1/4 stroke	167
63	31	3/8	98	58	170	52	11.2	66	1/4 stroke	178

The dimensions for each mounting type are the same as those for the standard double acting single rod model. Please refer to pages 6 to 10.

Air Cylinder/Non-rotating Rod: Double Acting: Double Rod

Series CA2KW

ø40, ø50, ø63

How to Order

Without auto switch

CA2KW L 40 [] — 200 []

With auto switch

CDA2KW L 40 [] — 200 [] — Y7BW []

With auto switch

Non-rotating rod

Double rod type

Mounting

B	Basic
L	Axial foot
F	Front flange
G	Rear flange
T	Centre trunnion

Cylinders with built-in magnets

If built-in magnet type is ordered without auto switch, leave the field for the auto switch type blank.
(Example) CDA2KWL40-100

Bore size

40	40 mm
50	50 mm
63	63 mm

Port thread type

Nil	Rc
TN	NPT
TF	G

Cylinder stroke (mm)

For more information, please refer to the next page.

Number of auto switches

Nil	2 pcs.
S	1 pc.
3	3 pcs.
n	"n" pcs.

Auto switch

Nil	Without auto switch
-----	---------------------

* Select an applicable auto switch model from the table below.

* D-Z7□, Z80, Y59□, Y69□, Y7□ are not mounted and are supplied loose. (Only the switch mounting brackets for these models are mounted.)

Cylinder suffix

Cushion	Nil	With cushion on both sides
	N	Without cushion

Applicable Auto Switch : Refer to page 5.3 of Best Pneumatics ② for detailed auto switch specifications.

Type	Special function	Electrical entry	Indicator light	Wiring (output)	Load voltage		Auto switch model	Lead wire length (m)*			Pre-wired connector	Applicable load		
					DC	AC		0.5 (Nil)	3 (L)	5 (Z)				
Reed switch	—	Grommet	Yes	3-wire (NPN equiv.)	—	5 V	—	Z76	●	●	—	—	IC circuit	—
	Diagnostic indication (2-colour indication)	Grommet	Yes	2-wire	24 V	12 V	100 V, 200 V	Z73 A54 A59W	●	●	—	—	—	Relay, PLC
Solid state switch	—	Grommet	Yes	3-wire (NPN)	24 V	5 V, 12 V	—	Y59A Y7P	●	●	○	○	IC circuit	Relay, PLC
	—	Grommet	Yes	3-wire (PNP)	—	—	100 V, 200 V	J51 Y59B	●	●	○	○	—	
	Diagnostic indication (2-colour indication)	Grommet	Yes	3-wire (NPN)	—	12 V	—	Y7NW	●	●	○	○	IC circuit	
	Water resistant (2-colour indication)	Grommet	Yes	3-wire (PNP)	—	5 V, 12 V	—	Y7PW	●	●	○	○	IC circuit	
	With diagnostic output (2-colour indication)	Grommet	Yes	2-wire	24 V	12 V	—	Y7BW	●	●	○	○	—	
	Latch type with diagnostic output (2-colour indication)	Grommet	Yes	4-wire (NPN)	—	5 V, 12 V	—	Y7BA F59F	—	●	○	○	IC circuit	
	Magnetic field resistant (2-colour indication)	Grommet	Yes	2-wire	—	—	—	F5LF P5DW	●	●	○	○	—	
	—	Grommet	Yes	2-wire	—	—	—	—	—	●	●	○	—	

* Lead wire length symbol 0.5 m.....Nil (Example) A54
3 m.....L (Example) A54L
5 m.....Z (Example) A54Z

* Solid state switches marked with "○" are produced upon receipt of order.

• In addition to the models in the above table, there are some other auto switches that are applicable. For more information, refer to page 15.

Air Cylinder/Non-rotating Rod: Double Acting: Double Rod *Series CA2KW*

Standard type
CA2

Standard type
CA2W

Standard/Non-rotating rod
CA2K

Standard/Non-rotating rod
CA2KW

Low friction
CA2□Q

End lock
CBA2

Air-hydro
CA2□H

Air-hydro
CA2W□H

Auto switch

Made to order

Precautions

Non-rotating accuracy/±0.5°
Same mounting dimensions as those of standard cylinder

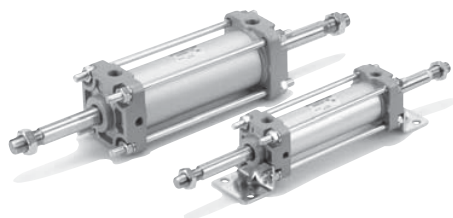

JIS symbol

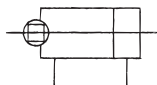

Made to Order Specifications
For more information, please refer to page 64.

Symbol	Specifications/Contents
-XC7	Tie-rod, cushion valve, and tie-rod nut and similar parts made of stainless steel
-XC14	Change of trunnion bracket mounting position
-XC15	Change of tie-rod length
-XC28	Compact flange made of SS400

Specifications

Fluid	Air
Proof pressure	1.5 MPa
Maximum operating pressure	1.0 MPa
Minimum operating pressure	0.08MPa
Ambient and fluid temperature	Without auto switch: -10 to 70°C, With auto switch: -10 to 60°C*
Piston speed	50 to 500 mm/s*
Cushion	Air cushion
Thread tolerance	JIS class 2
Stroke length tolerance	To 250 st : ₀ ^{+1.0} , 251 to 600 st : ₀ ^{+1.4}
Rod non-rotating accuracy	±0.5°
Allowable rotational torque	0.44Nm or less
Lubrication	Not required (Non-lube)
Mounting	Basic, Axial foot, Front flange, Rear flange, Centre trunnion

* With no freezing. * Operate within the range of absorbing kinetic energy. (Refer to page 3.)

Standard Stroke/ In case of a type with auto switch, please also refer to the table of minimum strokes for auto switch mounting on page 13.

Bore size (mm)	Standard stroke (mm)
40	25, 50, 75, 100, 125, 150, 175, 200, 250, 300, 350, 400, 450, 500*
50, 63	25, 50, 75, 100, 125, 150, 175, 200, 250, 300, 350, 400, 450, 500, 600*

* Intermediate strokes not listed above are also available.
Consult SMC for longer strokes than the strokes marked with*.

Weight/Aluminum Tube

		(kg)		
Bore size (mm)		40	50	63
Basic weight	Basic	1.01	1.54	2.17
	Axial foot	1.20	1.76	2.50
	Flange	1.38	1.99	2.96
	Trunnion	1.37	2.02	2.97
Additional weight by each 50 mm stroke		0.27	0.36	0.42
Accessories	Single knuckle	0.23	0.26	0.26
	Double knuckle (with pin)	0.37	0.43	0.43

Calculation example: Weight CA2KWL40-100

- Basic weight 1.20 (axial foot ø40)
 - Additional weight 0.27/50st
 - Cylinder stroke 100st
- 1.20 + 0.27 x 100/50 = 1.74 kg

The minimum stroke for auto switch mounting, proper auto switch mounting position and height, operating range, applicable auto switches, auto switch mounting brackets and their part numbers, and bracket part numbers are the same as those for the double acting single rod model of Series CA2.

Production of types with rod boot

Series CA2KW is also available with rod boot. Please consult SMC for more information.

Minimum Stroke for Auto Switch Mounting

⚠ Caution

¹ The minimum stroke for mounting varies with the auto switch type and mounting type of the cylinder. In particular, the centre trunnion type needs careful attention. (For more information, please refer to page 13.)

Series CA2KW

Copper Free

20—CA2KW **Mounting** **Bore size** **Stroke** **Suffix**

• Copper free

This cylinder eliminates any influences of copper ions or fluororesin on colour CRTs. Copper materials have been nickel plated or replaced with non-copper materials to prevent the generation of copper ions.

Specifications

Action	Double acting double rod
Bore size	ø40, ø50, ø63
Maximum operating pressure	1.0 MPa
Minimum operating pressure	0.08 MPa
Cushion	Air cushion
Piston speed	50 to 500 mm/s*
Mounting	Basic, Axial foot, Front flange, Rear flange, Centre trunnion

* Operate within the range of absorbable energy. (Refer to page 3.)

* Auto switch capable

Construction

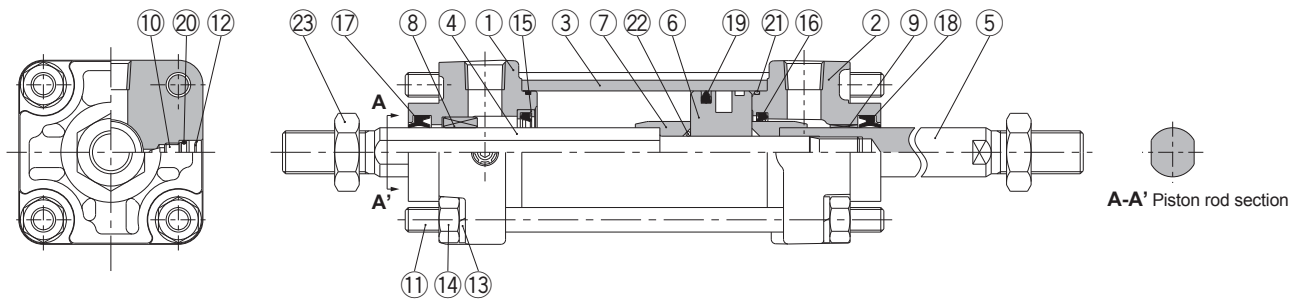

Parts List

No.	Description	Material	Note
1	Rod cover A	Aluminum alloy	Metallic painted
2	Rod cover B	Die-cast aluminum	Metallic painted
3	Cylinder tube	Aluminum alloy	Hard anodized
4	Piston rod A	Carbon steel	Hard chromium electroplated
5	Piston rod B	Carbon steel	Hard chromium electroplated
6	Piston	Aluminum alloy	Chromated
7	Cushion ring	Rolled steel	Zinc chromated
8	Non-rotating guide	Sintered alloy	
9	Bushing	Lead-bronze casting	
10	Cushion valve	Steel wire	Nickel plated
11	Tie-rod	Carbon steel	Corrosion resistant chromated
12	Snap ring	Spring steel	
13	Spring washer	Steel wire	Chromated
14	Tie-rod nut	Rolled steel	Nickel plated
15	Cushion seal holder	Aluminum alloy	
16	Cushion seal	Urethane	
17	Rod seal A	NBR	
18	Rod seal B	NBR	
19	Piston seal	NBR	
20	Cushion valve seal	NBR	
21	Cylinder tube gasket	NBR	
22	Piston gasket	NBR	O-ring
23	Rod end nut	Rolled steel	Nickel plated

Replacement Parts: Seal Kits

Bore size (mm)	Seal kit No.	Content
40	CA2KW40-PS	Consists of numbers 16, 17, 18, 19, and 21 above.
50	CA2KW50-PS	
63	CA2KW63-PS	

* The seal kits consist of items 16, 17, 18, 19, and 21. Please order them by using the seal kit number corresponding to each bore size.

Air Cylinder/Non-rotating Rod: Double Acting: Double Rod *Series CA2KW*

Basic/CA2KWB

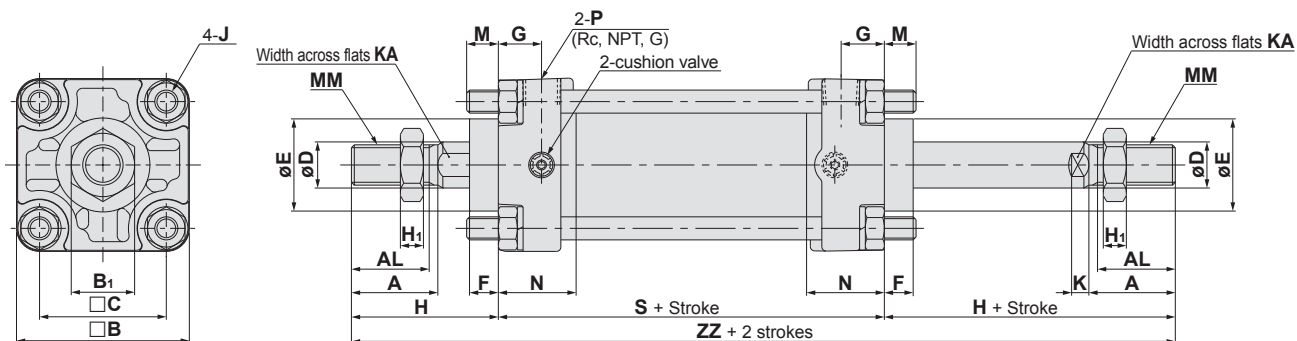

(mm)

Bore size (mm)	Stroke range (mm)	A	AL	□B	B ₁	□C	D	E	F	G	H ₁	J	K	KA	M	MM	N	P	S	H	ZZ
40	up to 500	30	27	60	22	44	16	32	10	15	8	M8	6	14	11	M14 x 1.5	27	1/4	84	51	186
50	up to 600	35	32	70	27	52	20	40	10	17	11	M8	7	18	11	M18 x 1.5	30	3/8	90	58	206
63	up to 600	35	32	85	27	64	20	40	10	17	11	M10 x 1.25	7	18	14	M18 x 1.5	31	3/8	98	58	214

The dimensions for each mounting type are the same as those for the standard double acting double rod model. Please refer to pages 19 to 20.

Standard type
CA2

Standard type
CA2W

Standard/Non-rotating rod
CA2K

Standard/Non-rotating rod
CA2KW

Low friction
CA2□Q

End lock
CBA2

Air-hydro
CA2□H

Air-hydro
CA2W□H

Auto switch

Made to order

Precautions

Air Cylinder/Low Friction

Series CA2□□Q

ø40, ø50, ø63, ø80, ø100

How to Order

Without auto switch

CA2 L Q □ □ 40 □ □ 150 F

With auto switch

CDA2 L Q □ □ 40 □ □ 150 F Y7BW □ □

With auto switch

Mounting

B	Basic
L	Axial foot
F	Front flange
G	Rear flange
C	Single clevis
D	Double clevis
T	Centre trunnion

Low friction

Tube material

Nil	Aluminum tube
F*	Steel tube

* Types with auto switch are not available.

Bore size

40	40 mm
50	50 mm
63	63 mm
80	80 mm
100	100 mm

Port thread type

Nil	Rc
TN	NPT
TF	G

Cylinders with built-in magnets

If built-in magnet type is ordered without auto switch, leave the field for the auto switch type blank.
(Example) CDA2BQ40-100

Number of auto switches

Nil	2 pcs.
S	1 pc.
3	3 pcs.
n	"n" pcs.

Auto switch

Nil	Without auto switch
-----	---------------------

* Select an applicable auto switch model from the table below.

* D-Z7□, Z80, Y59□, Y69□, Y7□ are not mounted and are supplied loose. (Only the switch mounting brackets for these models are mounted.)

Direction of low friction

F	With pressure at head side
B	With pressure at rod side

Cylinder stroke (mm)

For more information, please refer to the next page.

Applicable Auto Switch : Refer to page 5.3 of Best Pneumatics ② for detailed auto switch specifications.

Type	Special function	Electrical entry	Indicator/light	Wiring (output)	Load voltage		Auto switch model	Lead wire length (m)*			Pre-wired connector	Applicable load		
					DC	AC		0.5 (Nil)	3 (L)	5 (Z)				
Reed switch	—	Grommet	Yes	3 wire (NPN equiv.)	—	5 V	—	Z76	●	●	—	—	IC circuit	—
	Diagnostic indication (2-colour indication)	Grommet	Yes	2 wire	24 V	12 V	100 V	Z73	●	●	●	—	—	Relay, PLC
							100 V, 200 V	A54	●	●	●	—		
								A59W	●	●	—	—		
Solid state switch	—	Grommet	Yes	3 wire (NPN)	24 V	5 V, 12 V	—	Y59A	●	●	○	○	IC circuit	Relay, PLC
				3 wire (PNP)				Y7P	●	●	○	○		
	Diagnostic indication (2-colour indication)	Grommet	Yes	2 wire	—	—	100 V, 200 V	J51	●	●	○	—	—	
				3 wire (NPN)				Y59B	●	●	○	○		
	Water resistant (2-colour indication)	Grommet	Yes	3 wire (NPN)	24 V	5 V, 12 V	—	Y7NW	●	●	○	○	IC circuit	
				3 wire (PNP)				Y7PW	●	●	○	○		
	With diagnostic output (2-colour indication)	Grommet	Yes	2 wire	24 V	12 V	—	Y7BW	●	●	○	○	—	
				4 wire (NPN)				Y7BA	—	●	○	○		
	Latch type with diagnostic output (2-colour indication)	Grommet	Yes	2 wire	24 V	5 V, 12 V	—	F59F	●	●	○	○	IC circuit	
									F5LF	●	●	○		
Magnetic field resistant (2-colour indication)	Grommet	Yes	2 wire	24 V	—	—	P5DW	—	●	●	○	—		

* Lead wire length symbol 0.5 m.....Nil
3 m.....L
5 m.....Z

(Example) A54
(Example) A54L
(Example) A54Z

* Solid state switches marked with "○" are produced upon receipt of order.

** D-P5DW cannot be mounted on models with bore sizes ø40 and ø50

• In addition to the models in the above table, there are some other auto switches that are applicable. For more information, refer to page 39.

Standard type CA2
 Standard type CA2W
 Standard/Non-rotating rod CA2K
 Standard/Non-rotating rod CA2KW
 Low friction CA2□Q
 End lock CBA2
 Air-hydro CA2□H
 Air-hydro CA2W□H
 Auto switch
 Made to order
 Precautions

Designed with a low piston sliding resistance, this air cylinder is ideal for applications such as contact pressure control, which requires small movements at low pressures.

Low sliding resistance

Minimum operating pressure: -0.01 MPa

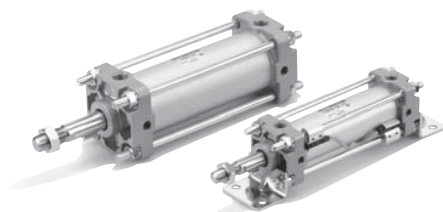

JIS symbol

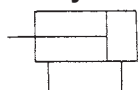

Made to Order Specifications
 For more information, please refer to page 64.

JIS symbol	Specifications/Contents
-XA□	Change of rod end shape
-XC3	Special port positions
-XC14	Change of trunnion bracket mounting position

Minimum stroke for auto switch mounting

Caution

- ① The minimum stroke for mounting varies with the auto switch type and mounting type of the cylinder. In particular, the centre trunnion type needs careful attention.
 (For more information, please refer to page 37.)

Low Friction Direction

To use the air cylinder as a balancer, pressurize it only from one of the ports as shown in the application example, and keep the other port open to the atmosphere.

Pressurized from rod cover port ·· Low friction direction B type (Application example ①)

Pressurized from head cover port ·· Low friction direction F type (Application example ②)

In either case, if the piston rod is moved by an external force, it will effect low friction operation both in the extending and retracting directions.

Applications

The low friction cylinder is used in combination with a precision regulator (such as the Series IR, etc.).

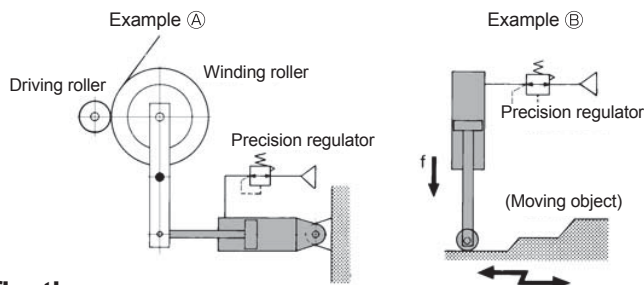

Specifications

Action	Double acting
Low friction direction	One direction (Refer to above "Low friction direction.")
Fluid	Air
Proof pressure	1.05 MPa
Maximum operating pressure	0.7 MPa
Minimum operating pressure	0.01MPa
Ambient and fluid temperature*	Without auto switch: -10 to 70°C, With auto switch: -10 to 60°C*
Allowable leakage	0.5 ℓ/min (ANR)
Cushion	Without
Thread tolerance	JIS class 2
Lubrication	Not required (Non-lube)
Mounting	Basic, Axial foot, Front flange, Rear flange, Single clevis, Double clevis, Centre trunnion

*With no freezing

Standard Stroke

Bore size (mm)	Standard stroke (mm)
40	25, 50, 75, 100, 125, 150, 175, 200, 250, 300, 350, 400, 450, 500
50, 63	25, 50, 75, 100, 125, 150, 175, 200, 250, 300, 350, 400, 450, 500, 600
80, 100	25, 50, 75, 100, 125, 150, 175, 200, 250, 300, 350, 400, 450, 500, 600, 700

* Intermediate strokes not listed above are also available.
 Consult SMC for strokes exceeding the above stroke ranges.

Accessory

Mounting		Basic	Foot	Front Flange	Rear Flange	Single clevis	Double clevis	Centre trunnion
Standard equipment	Rod end nut	●	●	●	●	●	●	●
	Clevis pin	—	—	—	—	—	●	—
Options	Single knuckle joint	●	●	●	●	●	●	●
	Double knuckle joint (with pin)	●	●	●	●	●	●	●

Series CA2□Q

Weight/Aluminum tube (Steel tube)

Bore size (mm)		40	50	63	80	100
Basic weight	Basic	0.89 (0.94)	1.36 (1.40)	2.00 (2.04)	3.48 (3.63)	4.87 (5.07)
	Axial foot	1.08 (1.13)	1.58 (1.62)	2.34 (2.38)	4.15 (4.30)	5.86 (6.06)
	Flange	1.26 (1.30)	1.81 (1.86)	2.79 (2.84)	4.93 (5.08)	6.79 (6.99)
	Single clevis	1.12 (1.17)	1.70 (1.74)	2.63 (2.67)	4.59 (4.74)	6.65 (6.86)
	Double clevis	1.16 (1.21)	1.79 (1.83)	2.79 (2.83)	4.88 (5.03)	7.17 (7.38)
	Trunnion	1.25 (1.35)	1.84 (1.94)	2.80 (3.00)	5.03 (5.32)	7.15 (7.54)
	Additional weight by each 50 mm stroke	All mounting brackets (except for steel tube trunnion)	0.22 (0.28)	0.28 (0.35)	0.37 (0.43)	0.52 (0.70)
Accessories	Steel tube trunnion	(0.36)	(0.46)	(0.65)	(0.86)	(1.07)
	Single knuckle	0.23	0.26	0.26	0.60	0.83
	Double knuckle (with pin)	0.37	0.43	0.43	0.87	1.27

Calculation example: CA2LQ40-100F (axial foot type, ø40, 100st)

- Basic weight 1.08kg
- Additional weight 0.22/50st
- Cylinder stroke 100st

$$1.08 + 0.22 \times 100/50 = 1.52 \text{ kg}$$

* Values inside the parentheses are those for the steel tube type.

Sliding Resistance of the Low Friction Side

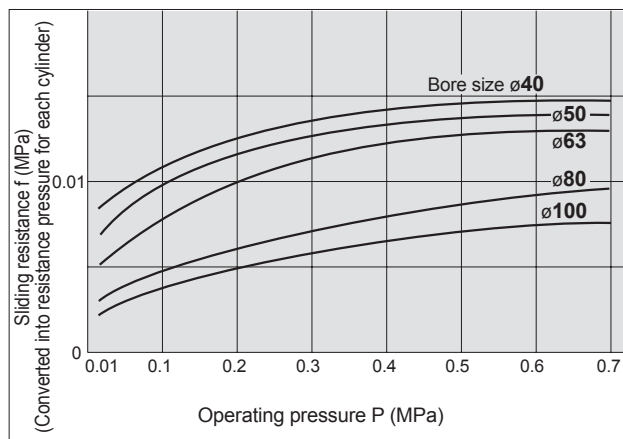

The actual sliding resistance F (N) can be found by the following equation from the sliding resistance f (MPa) (converted into resistance pressure of each cylinder) indicated by the ordinate of the graph.

$$\text{Sliding resistance } F \text{ (N)} = \text{Sliding resistance } f \text{ (MPa)} \times \text{Rod side piston area (mm}^2\text{)}$$

(Example) When a low friction cylinder with a bore size 63 mm is operated at 0.2 MPa, the sliding resistance f (MPa), a converted value of the actual sliding resistance into the cylinder pressure, is found to be 0.01 MPa in the graph. Thus, the actual sliding resistance F (N) can be found as follows:

$$F \text{ (N)} = 0.01 \text{ (MPa)} \times 2800 \text{ (mm}^2\text{)} = 28 \text{ (N)}$$

Mounting Bracket

Bore size (mm)	40	50	63	80	100
Axial foot*	CA2-L04	CA2-L05	CA2-L06	CA2-L08	CA2-L10
Flange	CA2-F04	CA2-F05	CA2-F06	CA2-F08	CA2-F10
Single clevis	CA2-C04	CA2-C05	CA2-C06	CA2-C08	CA2-C10
Double clevis**	CA2-D04	CA2-D05	CA2-D06	CA2-D08	CA2-D10

* When axial foot brackets are used, two pieces should be ordered for each cylinder.

**Double clevis type is packed with clevis pin, flat washer and cotter pin.

Auto Switch Mounting Bracket Part No.

Auto switch model	Bore size (mm)				
	40	50	63	80	100
D-A5□/A6□ D-A59W D-F5□/J5□ D-F5□W/J59W D-F5□F/F5NLT	BT-04	BT-04	BT-06	BT-08	BT-08
*** D-A3□/A44 *** D-G39/K39	BD1-04M	BD1-05M	BD1-06M	BD1-08M	BD1-10M
*** D-B5□/B64 *** D-B59W *** D-G5□/K59 *** D-G5□W/K59W *** D-G59F *** D-G5NLT	BA-04	BA-05	BA-06	BA-08	BA-10
* D-A3□C/A44C * D-G39C/K39C	BA3-040	BA3-050	BA3-063	BA3-080	BA3-100
D-Z7□/Z80 D-Y59□/Y69□ D-Y7P/Y7PV D-Y7□W D-Y7□WV D-Y7BAL	BA4-040	BA4-040	BA4-063	BA4-080	BA4-080
D-P5DWL	BAP2-040	BAP2-040	BAP2-063	BAP2-080	BAP2-080

* Mounting brackets are attached to models D-A3□C, A44C, G39C and K39C.

When placing an order, indicate as described below, in accordance with the cylinder size.

(Example) ø40...D-A3□C-4, ø80...D-A3□C-8,
ø50...D-A3□C-5, ø100...D-A3□C-10
ø63...D-A3□C-6,

When other brackets are ordered separately, order by the above part numbers.

*** Stainless steel mounting screw kit

A set of stainless steel mounting screws (with set screws) described below is available and can be used as required by the operating environment. (The mounting bracket and band for auto switches must be ordered separately, as they are not included.)

BBA1: D-A5/A6/F5/J5

BBA3: D-B5/B6/G5/K5

When a switch model D-F5BAL or G5BAL is mounted on the cylinder at the time of shipment, the above stainless steel screws are used. When the switch is shipped alone, BBA1 or BBA3 is attached.

*** Series CDA2 models vary in the thickness of the cylinder tube wall. In cases where the band mount type is used as an applicable auto switch, select the part number of the new band referring to page 79 whenever the cylinder model is changed.

Construction

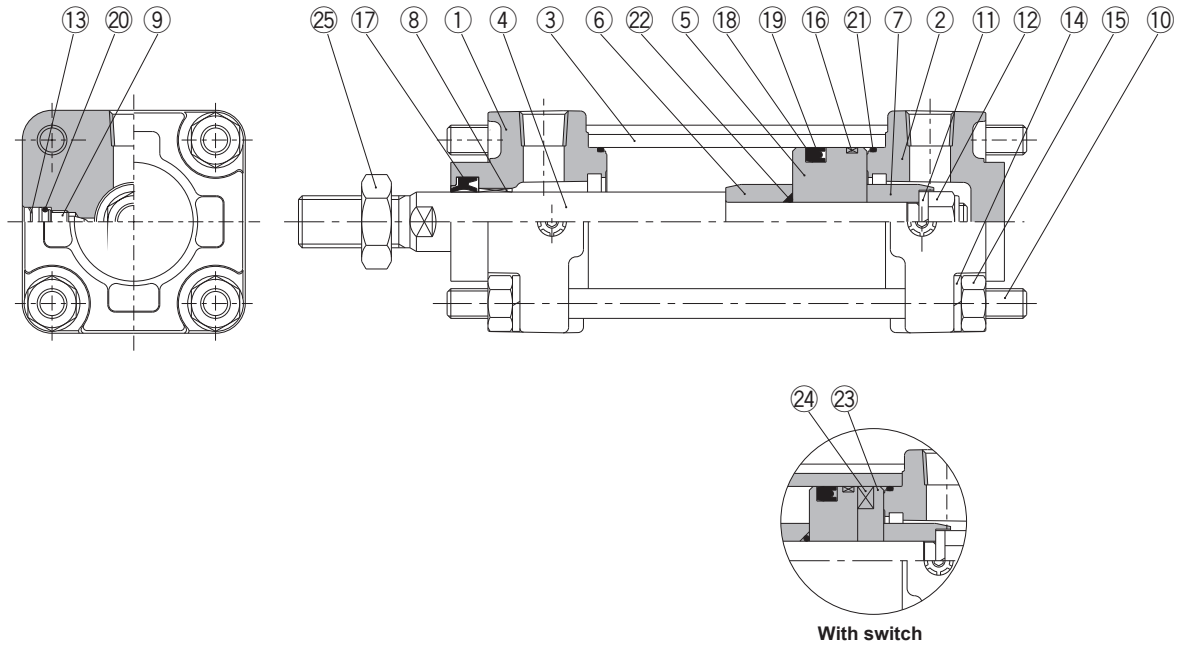

Parts List

No.	Description	Material	Note
1	Rod cover	Aluminum alloy	Metallic painted
2	Head cover	Aluminum alloy	Metallic painted
3	Cylinder tube	Aluminum alloy	Hard anodized
4	Piston rod	Carbon steel	Hard chromium electroplated
5	Piston	Aluminum alloy	Chromated
6	Cushion ring A	Rolled steel	Zinc chromated
7	Cushion ring B	Rolled steel	Zinc chromated
8	Bushing	Lead-bronze casting	
9	Cushion valve	Steel wire	Nickel plated
10	Tie-rod	Carbon steel	Corrosion resistant chromated
11	Spring washer	Steel wire	Zinc chromated
12	Piston nut	Rolled steel	Zinc chromated
13	Snap ring	Spring steel	
14	Spring washer	Steel wire	Nickel plated
15	Tie-rod nut	Rolled steel	Chromated
16	Wear ring	Resin	
17	Rod seal	NBR	
18	Piston seal	NBR	
19	Back-up O-ring	NBR	
20	Cushion valve seal	NBR	
21	Cylinder tube gasket	NBR	
22	Piston gasket	NBR	O-ring
23	Spacer	Aluminum alloy	Chromated
24	Magnet	—	
25	Rod end nut	Rolled steel	Nickel plated

Replacement Parts: Seal Kits

Bore size (mm)	Seal kit No.	Content
40	MBQ40-PS	Consists of numbers 17, 18, 19, and 21 above.
50	MBQ50-PS	
63	MBQ63-PS	
80	MBQ80-PS	
100	MBQ100-PS	

* The seal kits consist of items, 17, 18, 19, 21. Please order them by using the seal kit number corresponding to each bore size.

Standard type
CA2

Standard type
CA2W

Standard/Non-rotating rod
CA2K

Standard/Non-rotating rod
CA2KW

Low friction
CA2□□Q

End lock
CBA2

Air-hydro
CA2□□H

Air-hydro
CA2W□□H

Auto switch

Made to order

Precautions

Series CA2□Q

Basic/CA2BQ

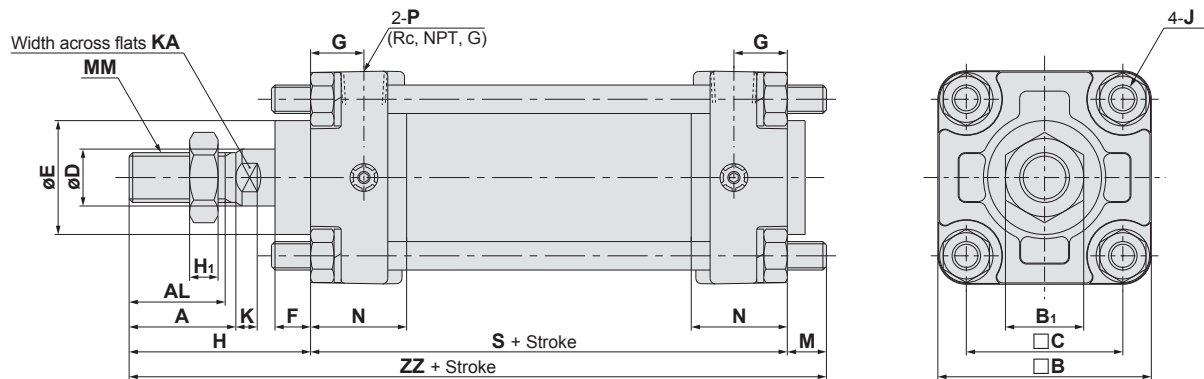

Bore size (mm)	Stroke range	A	AL	□B	B ₁	□C	D	E	F	G	H	H ₁	J	K	KA	M	MM	N	P	Without auto switch		With auto switch	
																				S	ZZ	S	ZZ
40	up to 500	30	27	60	22	44	16	32	10	15	51	8	M8	6	14	11	M14 x 1.5	27	1/4	84	146	94	156
50	up to 600	35	32	70	27	52	20	40	10	17	58	11	M8	7	18	11	M18 x 1.5	30	3/8	90	159	100	169
63	up to 600	35	32	85	27	64	20	40	10	17	58	11	M10 x 1.25	7	18	14	M18 x 1.5	31	3/8	98	170	108	180
80	up to 750	40	37	102	32	78	25	52	14	21	71	13	M12	10	22	17	M22 x 1.5	37	1/2	116	204	126	214
100	up to 750	40	37	116	41	92	30	52	14	21	72	16	M12	10	26	17	M26 x 1.5	40	1/2	126	215	136	225

Axial Foot/CA2LQ

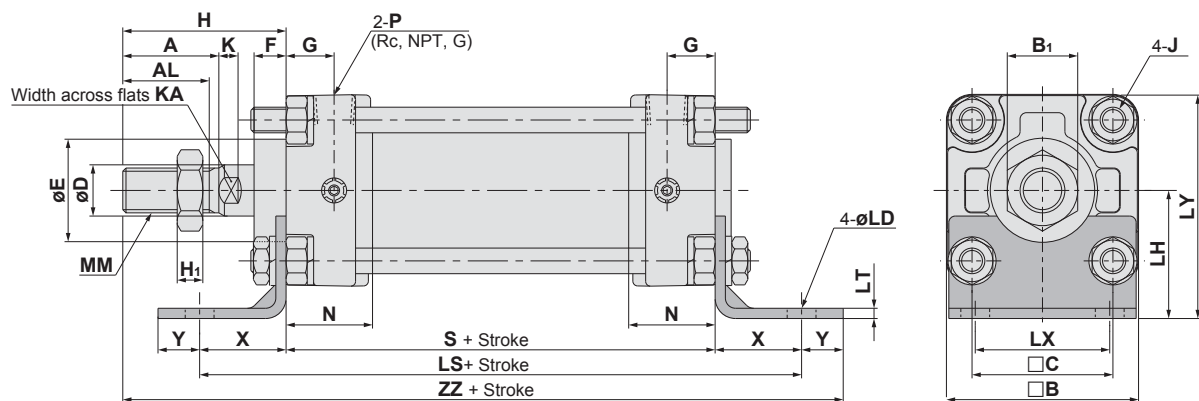

Bore size (mm)	Stroke range	A	AL	□B	B ₁	□C	D	E	F	G	H	H ₁	J	K	KA	LD	LH	LT	LX	LY	MM	N	P	X
50	up to 600	35	32	70	27	52	20	40	10	17	58	11	M8	7	18	9	45	3.2	50	80	M18 x 1.5	30	3/8	27
63	up to 600	35	32	85	27	64	20	40	10	17	58	11	M10 x 1.25	7	18	11.5	50	3.2	59	93	M18 x 1.5	31	3/8	34
80	up to 750	40	37	102	32	78	25	52	14	21	71	13	M12	10	22	13.5	65	4.5	76	116	M22 x 1.5	37	1/2	44
100	up to 750	40	37	116	41	92	30	52	14	21	72	16	M12	10	26	13.5	75	6	92	133	M26 x 1.5	40	1/2	43

Bore size (mm)	Y	Without auto switch			With auto switch		
		S	LS	ZZ	S	LS	ZZ
40	13	84	138	175	94	148	185
50	13	90	144	188	100	154	198
63	16	98	166	206	108	176	216
80	16	116	204	247	126	214	257
100	17	126	212	258	136	222	268

Front Flange/CA2FQ

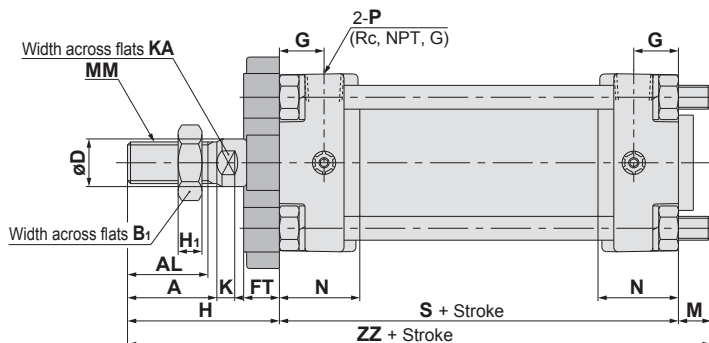
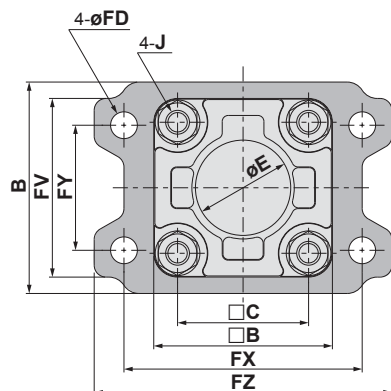

Bore size (mm)	Stroke range	A	AL	B	B ₁	C	D	E	FV	FD	FT	FX	FY	FZ	G	H	H ₁	J	K	KA	M	MM	N	P	Without auto switch		With auto switch		
		S	ZZ	S	ZZ																								
40	up to 500	30	27	71	60	22	44	16	32	60	9	12	80	42	100	15	51	8	M8	6	14	11	M14 x 1.5	27	1/4	84	146	94	156
50	up to 600	35	32	81	70	27	52	20	40	70	9	12	90	50	110	17	58	11	M8	7	18	11	M18 x 1.5	30	3/8	90	159	100	169
63	up to 600	35	32	101	85	27	64	20	40	86	11.5	15	105	59	130	17	58	11	M10 x 1.25	7	18	14	M18 x 1.5	31	3/8	98	170	108	180
80	up to 750	40	37	119	102	32	78	25	52	102	13.5	18	130	76	160	21	71	13	M12	10	22	17	M22 x 1.5	37	1/2	116	204	126	214
100	up to 750	40	37	133	116	41	92	30	52	116	13.5	18	150	92	180	21	72	16	M12	10	26	17	M26 x 1.5	40	1/2	126	215	136	225

Rear Flange/CA2GQ

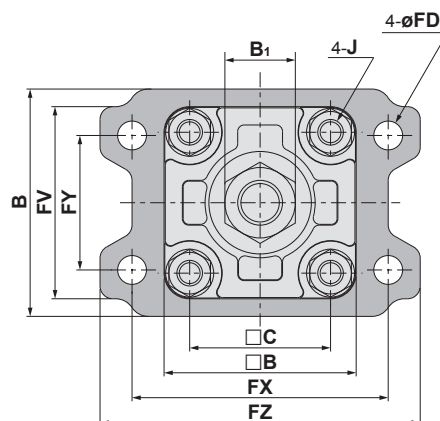
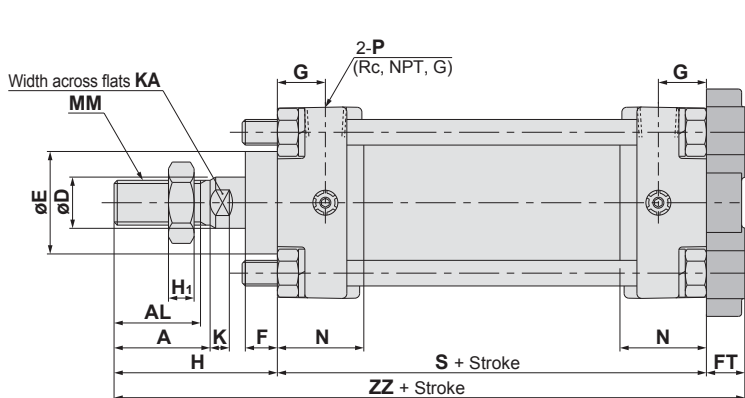

Bore size (mm)	Stroke range	A	AL	B	B ₁	C	D	E	FV	FD	FT	FX	FY	FZ	G	H	H ₁	J	K	KA	MM	N	P	Without auto switch		With auto switch			
		S	ZZ	S	ZZ																								
40	up to 500	30	27	71	60	22	44	16	32	60	9	12	80	42	100	15	51	8	M8	6	14	11	M14 x 1.5	27	1/4	84	147	94	157
50	up to 600	35	32	81	70	27	52	20	40	70	9	12	90	50	110	17	58	11	M8	7	18	11	M18 x 1.5	30	3/8	90	160	100	170
63	up to 600	35	32	101	85	27	64	20	40	86	11.5	15	105	59	130	17	58	11	M10 x 1.25	7	18	14	M18 x 1.5	31	3/8	98	171	108	181
80	up to 750	40	37	119	102	32	78	25	52	102	13.5	18	130	76	160	21	71	13	M12	10	22	17	M22 x 1.5	37	1/2	116	205	126	215
100	up to 750	40	37	133	116	41	92	30	52	116	13.5	18	150	92	180	21	72	16	M12	10	26	17	M26 x 1.5	40	1/2	126	216	136	226

Standard type
CA2

Standard type
CA2W

Standard/Non-rotating rod
CA2K

Standard/Non-rotating rod
CA2KW

Low friction
CA2□Q

End lock
CBA2

Air-hydro
CA2□H

Air-hydro
CA2W□H

Auto switch

Made to order

Precautions

Series CA2□Q

Single Clevis/CA2CQ

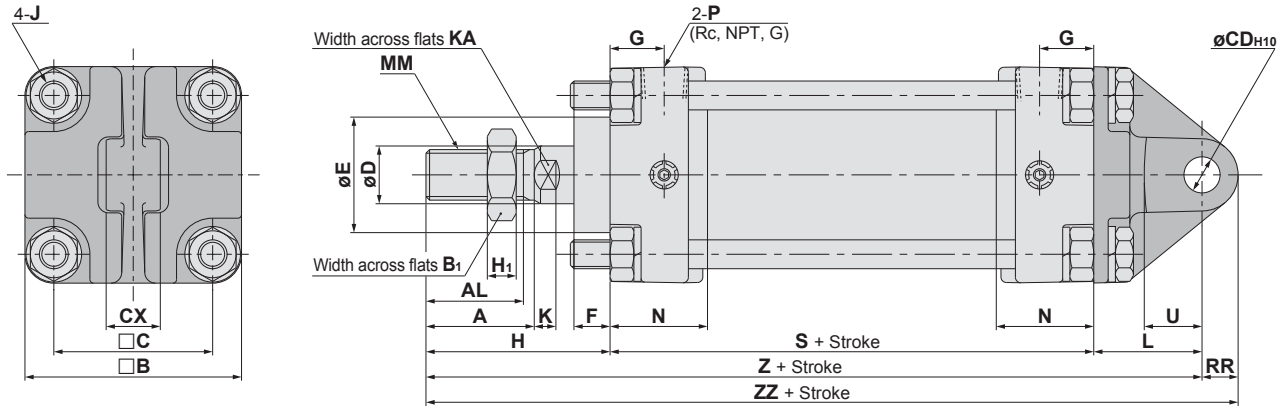

Bore size (mm)	Stroke range	A	AL	B	B ₁	C	CD _{H10}	CX	D	E	F	G	H	H ₁	J	K	KA	L	MM	N	P	RR	U	Without auto switch			With auto switch		
																								S	Z	ZZ	S	Z	ZZ
40	up to 500	30	27	60	22	44	10 ^{+0.058} ₀	15 ^{+0.1} _{-0.3}	16	32	10	15	51	8	M8	6	14	30	M14 x 1.5	27	1/4	10	16	84	165	175	94	175	185
50	up to 600	35	32	70	27	52	12 ^{+0.070} ₀	18 ^{+0.1} _{-0.3}	20	40	10	17	58	11	M8	7	18	35	M18 x 1.5	30	3/8	12	19	90	183	195	100	193	205
63	up to 600	35	32	85	27	64	16 ^{+0.070} ₀	25 ^{+0.1} _{-0.3}	20	40	10	17	58	11	M10 x 1.25	7	18	40	M18 x 1.5	31	3/8	16	23	98	196	212	108	206	222
80	up to 750	40	37	102	32	78	20 ^{+0.084} ₀	31.5 ^{+0.1} _{-0.3}	25	52	14	21	71	13	M12	10	22	48	M22 x 1.5	37	1/2	20	28	116	235	255	126	245	265
100	up to 750	40	37	116	41	92	25 ^{+0.084} ₀	35.5 ^{+0.1} _{-0.3}	30	52	14	21	72	16	M12	10	26	58	M26 x 1.5	40	1/2	25	36	126	256	281	136	266	291

Double Clevis/CA2DQ

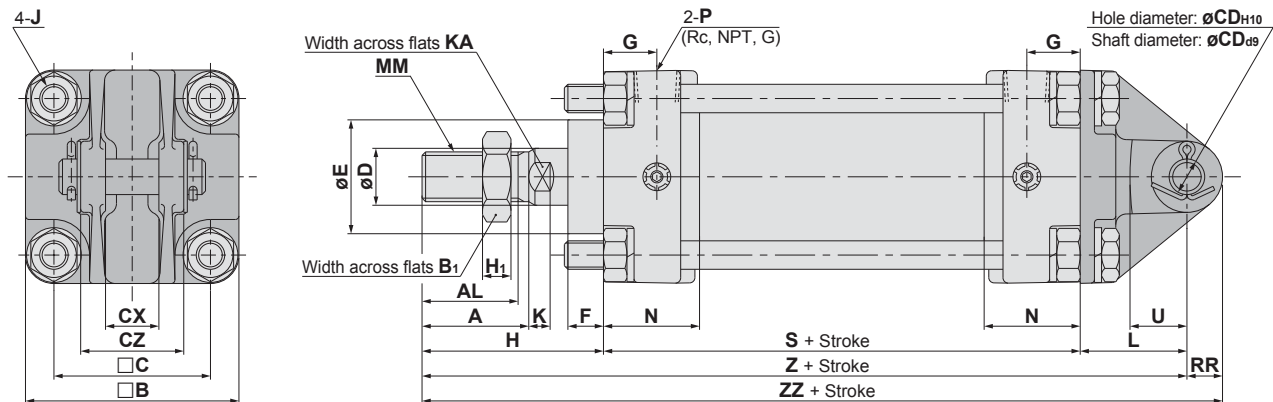

Bore size (mm)	Stroke range	A	AL	B	B ₁	C	CD _{H10}	CX	CZ	D	E	F	G	H	H ₁	J	K	KA	L	MM	N	P	RR	U	Without auto switch			With auto switch		
																									S	Z	ZZ	S	Z	ZZ
40	up to 500	30	27	60	22	44	10 ^{+0.058} ₀	15 ^{+0.3} _{+0.1}	29.5	16	32	10	15	51	8	M8	6	14	30	M14 x 1.5	27	1/4	10	16	84	165	175	94	175	185
50	up to 600	35	32	70	27	52	12 ^{+0.070} ₀	18 ^{+0.3} _{+0.1}	38	20	40	10	17	58	11	M8	7	18	35	M18 x 1.5	30	3/8	12	19	90	183	195	100	193	205
63	up to 600	35	32	85	27	64	16 ^{+0.070} ₀	25 ^{+0.3} _{+0.1}	49	20	40	10	17	58	11	M10 x 1.25	7	18	40	M18 x 1.5	31	3/8	16	23	98	196	212	108	206	222
80	up to 750	40	37	102	32	78	20 ^{+0.084} ₀	31.5 ^{+0.3} _{+0.1}	61	25	52	14	21	71	13	M12	10	22	48	M22 x 1.5	37	1/2	20	28	116	235	255	126	245	265
100	up to 750	40	37	116	41	92	25 ^{+0.084} ₀	35.5 ^{+0.3} _{+0.1}	64	30	52	14	21	72	16	M12	10	26	58	M26 x 1.5	40	1/2	25	36	126	256	281	136	266	291

Center Trunnion/CA2TQ

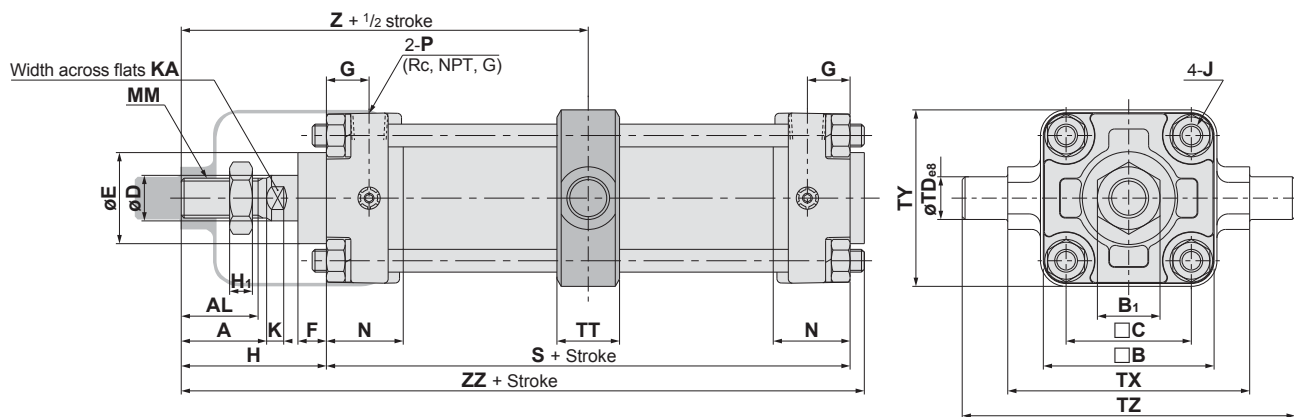

(mm)

Bore size (mm)	Stroke range	A	AL	□B	B ₁	□C	D	E	F	G	H	H ₁	J	K	KA	MM	N	P	TD _{e8}	TT	TX	TY	TZ	Without auto switch			With auto switch		
		S	Z	ZZ	S	Z	ZZ																						
40	up to 500	30	27	60	22	44	16	32	10	15	51	8	M8	6	14	M14 x 1.5	27	1/4	15 ^{-0.032} _{-0.059}	22	85	62	117	84	93	140	94	98	150
50	up to 600	35	32	70	27	52	20	40	10	17	58	11	M8	7	18	M18 x 1.5	30	3/8	15 ^{-0.032} _{-0.059}	22	95	74	127	90	103	154	100	108	164
63	up to 600	35	32	85	27	64	20	40	10	17	58	11	M10 x 1.25	7	18	M18 x 1.5	31	3/8	18 ^{-0.032} _{-0.059}	28	110	90	148	98	107	162	108	112	172
80	up to 750	40	37	102	32	78	25	52	14	21	71	13	M12	10	22	M22 x 1.5	37	1/2	25 ^{-0.040} _{-0.073}	34	140	110	192	116	129	194	126	134	204
100	up to 750	40	37	116	41	92	30	52	14	21	72	16	M12	10	26	M26 x 1.5	40	1/2	25 ^{-0.040} _{-0.073}	40	162	130	214	126	135	206	136	140	216

- Standard type CA2
- Standard type CA2W
- Standard/Non-rotating rod CA2K
- Standard/Non-rotating rod CA2KW
- Low friction CA2□Q
- End lock CBA2
- Air-hydro CA2□H
- Air-hydro CA2W□H
- Auto switch
- Made to order
- Precautions

Series CA2□Q

Minimum Auto Switch Mounting Stroke

n: Number of auto switches

Auto switch model	Number of auto switch	Brackets other than center trunnion	Center trunnion				
			ø40	ø50	ø63	ø80	ø100
D-A5□, A6□ D-F5□, J5□ D-F5□W, J59W D-F5BAL, D-F59F	2 (Different side and same side) 1	15	90		100	110	120
	n (Same side)	$15 + 55 \frac{(n-2)}{2}$ n = 2, 4, 6, 8...	$90 + 55 \frac{(n-4)}{2}$ n = 4, 8, 12, 16...	$100 + 55 \frac{(n-4)}{2}$ n = 4, 8, 12, 16...	$110 + 55 \frac{(n-4)}{2}$ n = 4, 8, 12, 16...	$120 + 55 \frac{(n-4)}{2}$ n = 4, 8, 12, 16...	
D-A59W	2 (Different side and same side)	20	90		100	110	120
	n (Same side)	$20 + 55 \frac{(n-2)}{2}$ n = 2, 4, 6, 8...	$90 + 55 \frac{(n-4)}{2}$ n = 4, 8, 12, 16...	$100 + 55 \frac{(n-4)}{2}$ n = 4, 8, 12, 16...	$110 + 55 \frac{(n-4)}{2}$ n = 4, 8, 12, 16...	$120 + 55 \frac{(n-4)}{2}$ n = 4, 8, 12, 16...	
	1	15	90		100	110	120
D-F5LF D-F5NTL	2 (Different side and same side) 1	25	110		120	130	140
	n (Same side)	$25 + 55 \frac{(n-2)}{2}$ n = 2, 4, 6, 8...	$110 + 55 \frac{(n-4)}{2}$ n = 4, 8, 12, 16...	$120 + 55 \frac{(n-4)}{2}$ n = 4, 8, 12, 16...	$130 + 55 \frac{(n-4)}{2}$ n = 4, 8, 12, 16...	$140 + 55 \frac{(n-4)}{2}$ n = 4, 8, 12, 16...	
D-B5□, B64 D-G5□, K59 *D-G5□W *D-K59W *D-G5BAL *D-G59F D-G5NTL	2	Different side	15	90	100	110	
		Same side	75	90	100	110	
	n	Different side	$15 + 50 \frac{(n-2)}{2}$ n = 2, 4, 6, 8, ..	$90 + 50 \frac{(n-4)}{2}$ n = 4, 8, 12, 16, ..	$100 + 50 \frac{(n-4)}{2}$ n = 4, 8, 12, 16, ..	$100 + 50 \frac{(n-4)}{2}$ n = 4, 8, 12, 16, ..	
		Same side	$75 + 50(n-2)$ n = 2, 3, 4, ..	$90 + 50(n-2)$ n = 2, 4, 6, 8, ..	$100 + 50(n-2)$ n = 2, 4, 6, 8, ..	$110 + 50(n-2)$ n = 2, 4, 6, 8, ..	
	1	10	90		100	110	
	D-B59W	2	Different side	20	90	100	110
Same side			75	90	100	110	
n		Different side	$20 + 50 \frac{(n-2)}{2}$ n = 2, 4, 6, 8, ..	$90 + 50 \frac{(n-4)}{2}$ n = 4, 8, 12, 16, ..	$100 + 50 \frac{(n-4)}{2}$ n = 4, 8, 12, 16, ..	$110 + 50 \frac{(n-4)}{2}$ n = 4, 8, 12, 16, ..	
		Same side	$75 + 50(n-2)$ n = 2, 3, 4, ..	$90 + 50(n-2)$ n = 2, 4, 6, 8, ..	$100 + 50(n-2)$ n = 2, 4, 6, 8, ..	$110 + 50(n-2)$ n = 2, 4, 6, 8, ..	
1		15	90		100	110	
*D-A3□ *D-G39 *D-K39		2	Different side	35	—	80	90
	Same side		100	—	100	100	
	n	Different side	$35 + 30(n-2)$ n = 2, 3, 4, ..	—	$80 + 30(n-2)$ n = 2, 4, 6, 8, ..	$90 + 30(n-2)$ n = 2, 4, 6, 8, ..	
		Same side	$100 + 100(n-2)$ n = 2, 3, 4, ..	—	$100 + 100(n-2), n = 2, 4, 6, 8, ..$		
	1	10	—	80	90		
	*D-A44	2	Different side	35	—	80	90
Same side			55	—	80	90	
n		Different side	$35 + 30(n-2)$ n = 2, 3, 4, ..	—	$80 + 30(n-2)$ n = 2, 4, 6, 8, ..	$90 + 30(n-2)$ n = 2, 4, 6, 8, ..	
		Same side	$55 + 50(n-2)$ n = 2, 3, 4, ..	—	$80 + 50(n-2)$ n = 2, 4, 6, 8, ..	$90 + 50(n-2)$ n = 2, 4, 6, 8, ..	
1		10	—	80	90		
*D-A3□C *D-G39C *D-K39C		2	Different side	20	—	80	90
	Same side		100	—	100	100	
	n	Different side	$20 + 35(n-2)$ n = 2, 3, 4, ..	—	$80 + 35(n-2)$ n = 2, 4, 6, 8, ..	$90 + 35(n-2)$ n = 2, 4, 6, 8, ..	
		Same side	$100 + 100(n-2)$ n = 2, 3, 4, ..	—	$100 + 100(n-2), n = 2, 4, 6, 8, ..$		
	1	10	—	80	90		
	*D-A44C	2	Different side	20	—	80	90
Same side			55	—	80	90	
n		Different side	$20 + 35(n-2)$ n = 2, 3, 4, ..	—	$80 + 35(n-2)$ n = 2, 4, 6, 8, ..	$90 + 35(n-2)$ n = 2, 4, 6, 8, ..	
		Same side	$55 + 50(n-2)$ n = 2, 3, 4, ..	—	$80 + 50(n-2)$ n = 2, 4, 6, 8, ..	$90 + 50(n-2)$ n = 2, 4, 6, 8, ..	
1		10	—	80	90		
D-Z7□, Z80 D-Y59□, Y7P D-Y7□W		2 (Different side and same side) 1	15	80	85	90	95
	n	$15 + 40 \frac{(n-2)}{2}$ n = 2, 4, 6, 8...	$80 + 40 \frac{(n-4)}{2}$ n = 4, 8, 12, 16...	$85 + 40 \frac{(n-4)}{2}$ n = 4, 8, 12, 16...	$90 + 40 \frac{(n-4)}{2}$ n = 4, 8, 12, 16...	$95 + 40 \frac{(n-4)}{2}$ n = 4, 8, 12, 16...	$105 + 40 \frac{(n-4)}{2}$ n = 4, 8, 12, 16...
D-Y69□, Y7PV D-Y7□WV	2 (Different side and same side) 1	10	65		75	80	90
	n	$10 + 30 \frac{(n-2)}{2}$ n = 2, 4, 6, 8...	$65 + 30 \frac{(n-4)}{2}$ n = 4, 8, 12, 16...	$75 + 30 \frac{(n-4)}{2}$ n = 4, 8, 12, 16...	$80 + 30 \frac{(n-4)}{2}$ n = 4, 8, 12, 16...	$90 + 30 \frac{(n-4)}{2}$ n = 4, 8, 12, 16...	
D-Y7BAL	2 (Different side and same side) 1	20	95		100	105	110
	n	$20 + 45 \frac{(n-2)}{2}$ n = 2, 4, 6, 8...	$95 + 45 \frac{(n-4)}{2}$ n = 4, 8, 12, 16...	$100 + 45 \frac{(n-4)}{2}$ n = 4, 8, 12, 16...	$105 + 45 \frac{(n-4)}{2}$ n = 4, 8, 12, 16...	$110 + 45 \frac{(n-4)}{2}$ n = 4, 8, 12, 16...	
D-P5DWL	2 (Different side and same side) 1	15	120		130	140	
	n	$15 + 65 \frac{(n-2)}{2}$ n = 2, 4, 6, 8...	$120 + 65 \frac{(n-4)}{2}$ n = 4, 8, 12, 16...	$130 + 65 \frac{(n-4)}{2}$ n = 4, 8, 12, 16...	$140 + 65 \frac{(n-4)}{2}$ n = 4, 8, 12, 16...		

*D-A3□, A3□C, A44, A44C, G39, G39C, K39, K39C, G5□W, K59W, G5BAL, G59F, and P5PWL cannot be mounted on models with bore sizes ø40 and ø50 mm.

Auto Switches/Proper Mounting Positions and Height for Stroke End Detection

<Band mount type>

<Tie-rod mount type>

D-B5□/B64/B59W

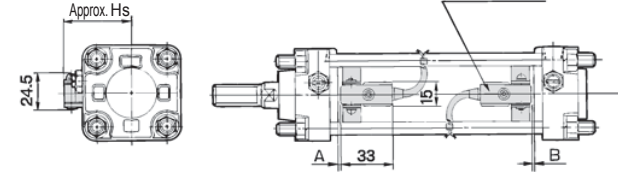

**D-A5□/A6□
D-A59W**

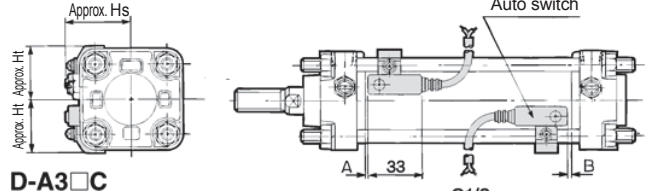

**D-A3□
D-G39/K39**

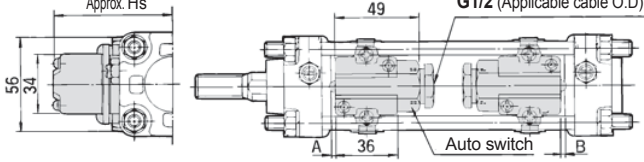

**D-A3□C
D-G39C/K39C**

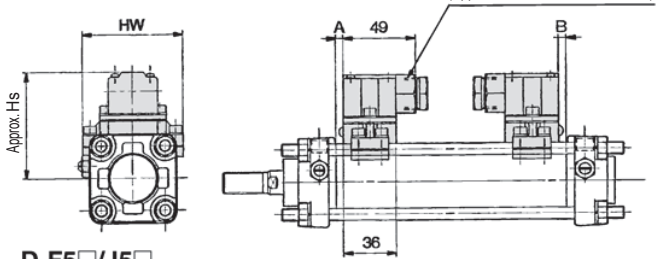

**D-G5□/K59
D-G5□W/K59W
D-G5BAL
D-G59F/G5NTL**

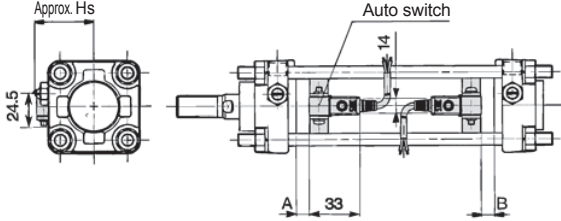

**D-F5□/J5□
D-F5NTL
D-F5□W/J59W
D-F5BAL/F5□F**

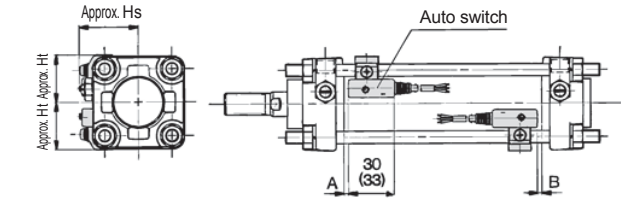

Values inside the parentheses are those for D-F5LF

D-A44

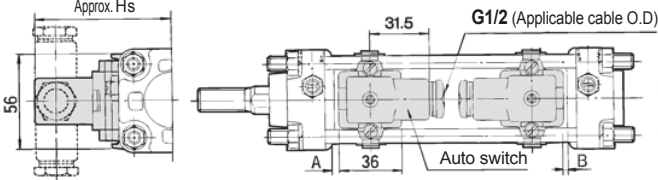

D-A44C

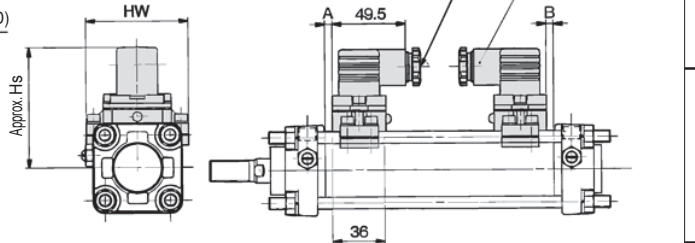

Proper Auto Switch Mounting Position

Auto switch model	D-A5□, A6□ D-A3□, A3□C D-A44, A44C D-G39, G39C D-K39, K39C		D-B5□ D-B64		D-B59W		D-F5□ D-F59F D-F5□W D-J59W D-F5BAL		D-G5□ D-K59 D-G5NTL D-G5□W D-K5W D-G5BAL D-G59F		D-A59W		D-F5LF		D-F5NTL	
	A	B	A	B	A	B	A	B	A	B	A	B	A	B	A	B
40	11.5	0	12	0	15	0	18	3	13.5	0	15.5	0.5	22	7	23	8
50	12	0	12.5	0	15.5	0	18.5	3	14	0	16	0.5	22.5	7	23.5	8
63	16.5	0	17	0	20	1	23	4	18.5	0	20.5	1.5	27	8	28	9
80	20.5	0	21	0	24	3	27	6	22.5	1.5	24.5	3.5	31	10	32	11
100	23.5	0	24	1	27	4	30	7	25.5	2.5	27.5	4.5	34	11	35	12

Auto Switch Mounting Height

Auto switch model	D-B5□, B64 D-B59W D-G5□ D-K59 D-G5NTL D-G5□W D-K59W D-G5BAL D-G59F		D-A3□ D-G39 D-K39		D-A44		D-A5□ D-A6□ D-A59W		D-F5□ D-J59 D-F5□W D-J59W D-F5BAL D-F5□F D-F5NTL		D-A3□C D-G39C D-K39C		D-A44C	
	Hs	Ht	Hs	Ht	Hs	Ht	Hs	Ht	Hs	Ht	Hs	Hw	Hs	Hw
40	38	—	—	—	40	31	38.5	31	—	—	—	—	—	—
50	43.5	—	—	—	43.5	35	42.5	35	—	—	—	—	—	—
63	50.5	85	93	49	42	48	42	85.5	91	93.5	91	—	—	—
80	59	93.5	101.5	55.5	50	54	50	94	107	102	107	—	—	—
100	69.5	104	112	63	57.5	62	57.5	104	121	112	121	—	—	—

* D-A3□, A3□C, A44, A44C, G39, G39C, K39, K39C, G5□W, K59W, G5BAL, and G59F cannot be mounted on models with bore sizes Ø40 and Ø50 mm.

Standard type CA2
 Standard type CA2W
 Standard/Non-rotating rod CA2K
 Standard/Non-rotating rod CA2KW
 Low friction CA2□□
 End lock CBA2
 Air-hydro CA2□H
 Air-hydro CA2W□H
 Auto switch
 Made to order
 Precautions

Series CA2□Q

Auto Switches/Proper Mounting Positions and Height for Stroke End Detection

<Tie-rod mount type>

D-Z7□/Z80
D-Y59□/Y69□/Y7P/Y7PV
D-Y7□W/Y7□WV
D-Y7BAL

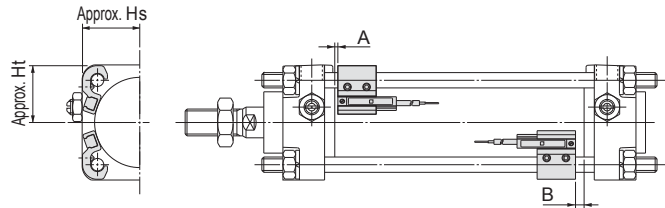

D-P5DWL

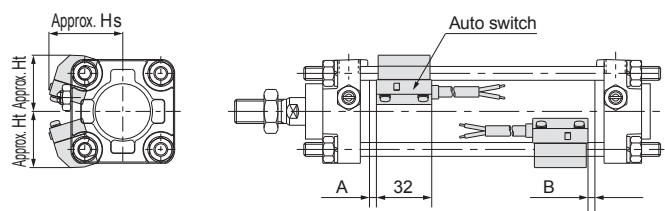

Proper Auto Switch Mounting Position

(mm)

Auto switch model	D-Z7□, Z80 D-Y59□, Y69□ D-Y7P, Y7PV D-Y7□W D-Y7□WV D-Y7BAL		D-P5DWL*	
	A	B	A	B
Bore size (mm)				
40	15	0	—	—
50	15.5	0	—	—
63	20	1	19.5	0.5
80	24	3	23.5	2.5
100	27	4	26.5	3.5

* It cannot be mounted on models with bore sizes ø40 and ø50 mm.

Auto Switch Mounting Height

(mm)

Auto switch model	D-Z7□ D-Z80 D-Y59□ D-Y7P D-Y7□W		D-Y69□ D-Y7PV D-Y7□WV		D-Y7BAL		D-P5DWL	
	Hs	Ht	Hs	Ht	Hs	Ht	Hs	Ht
Bore size (mm)								
40	30	30	30.5	30	34	30	—	—
50	34	34	35	34	38.5	34	—	—
63	41	41	42.5	41	46.5	41	53	44
80	49.5	48.5	51	48.5	55	48.5	60	52
100	58.5	56	59	56	63	56	67	59

Operating Range

(mm)

Auto switch model	Bore size				
	40	50	63	80	100
D-Z7□, Z80	8	7	9	9.5	10.5
D-A3□, A44, A3□C, A44C	9	10	11	11	11
D-A5□, A6□					
D-B5□, B64					
D-A59W	13	13	14	14	15
D-B59W	14	14	17	16	18
D-Y59□, Y69□, Y7P, Y7□V, Y7□W, Y7□WV	8	7	5.5	6.5	6.5
D-Y7BAL	3.5	3.5	5	5	5
D-F5□, J5□, F5□W, J59W, F5BAL, F5NTL	4	4	4.5	4.5	4.5
D-F59F	5.5	5	5.5	5.5	5.5
D-G5□, K59, G5□W, K59W, G5BAL, G5NTL, G59F	5	6	6.5	6.5	7
D-G39, K39, G39C, K39C	—	—	10	10	11
D-P5DWL	—	—	4.5	4	4.5

* The above operating ranges are provided as guidelines including the hysteresis and are not guaranteed values (with approx. ±30% variations). They may vary significantly with the surrounding environment.

In addition to the models listed in "How to Order," the following auto switches are applicable.

Please contact SMC for further details on auto switch specifications.

Auto switch type	Mounting	Part No.	Electrical entry	Features
Reed	Tie-rod	D-A53, A56	Grommet (in-line)	—
		D-64, A67		Without indicator light
		D-Z80		—
		D-A33C, A34C*		Terminal conduit
	Band	D-A44C*	DIN terminal	—
		D-B53, B54	Grommet (in-line)	—
		D-B64		—
		D-B59W		2-colour indication
		D-A33, A34*	Terminal conduit	—
		D-A44*	DIN terminal	—

Auto switch type	Mounting	Part No.	Electrical entry	Features	
Solid state**	Tie-rod	D-F59, F5P, J59	Grommet (in-line)	—	
		D-F59W, F5PW, J59W		2-colour indication	
		D-F5BAL		2-colour indication, water resistant	
		D-F5NTL		With timer	
		D-Y69A, Y7PV, Y69B		—	
		D-Y7NW, Y7PW, Y7BW		2-colour indication	
		D-G39C, K39C*		Terminal conduit	—
	Band	D-G59, G5P, K59	Grommet (in-line)	—	
		D-G59W, G5PW, K59W*		2-colour indication	
		D-G5BAL*		2-colour indication, water resistant	
		D-G59F*		2-colour indication, latch type with diagnostic output	
		D-G5NTL		With timer	
		D-G39, K39*		Terminal conduit	—

* D-A3□, A3□C, A44, A44C, G39, G39C, K39, K39C, G5□W, K59W, G5BAL, and G59F cannot be mounted on models with bore sizes ø40 and ø50 mm.

** Solid state switches are also available with pre-wired connector. Please contact SMC for further details on auto switch specifications.

** The normally closed type (NC = b contact) of solid state auto switches (D-Y7G, Y7H) are also available. Please contact SMC for further details on auto switch specifications.

End Lock Cylinder

Series CBA2

ø40, ø50, ø63, ø80, ø100

How to Order

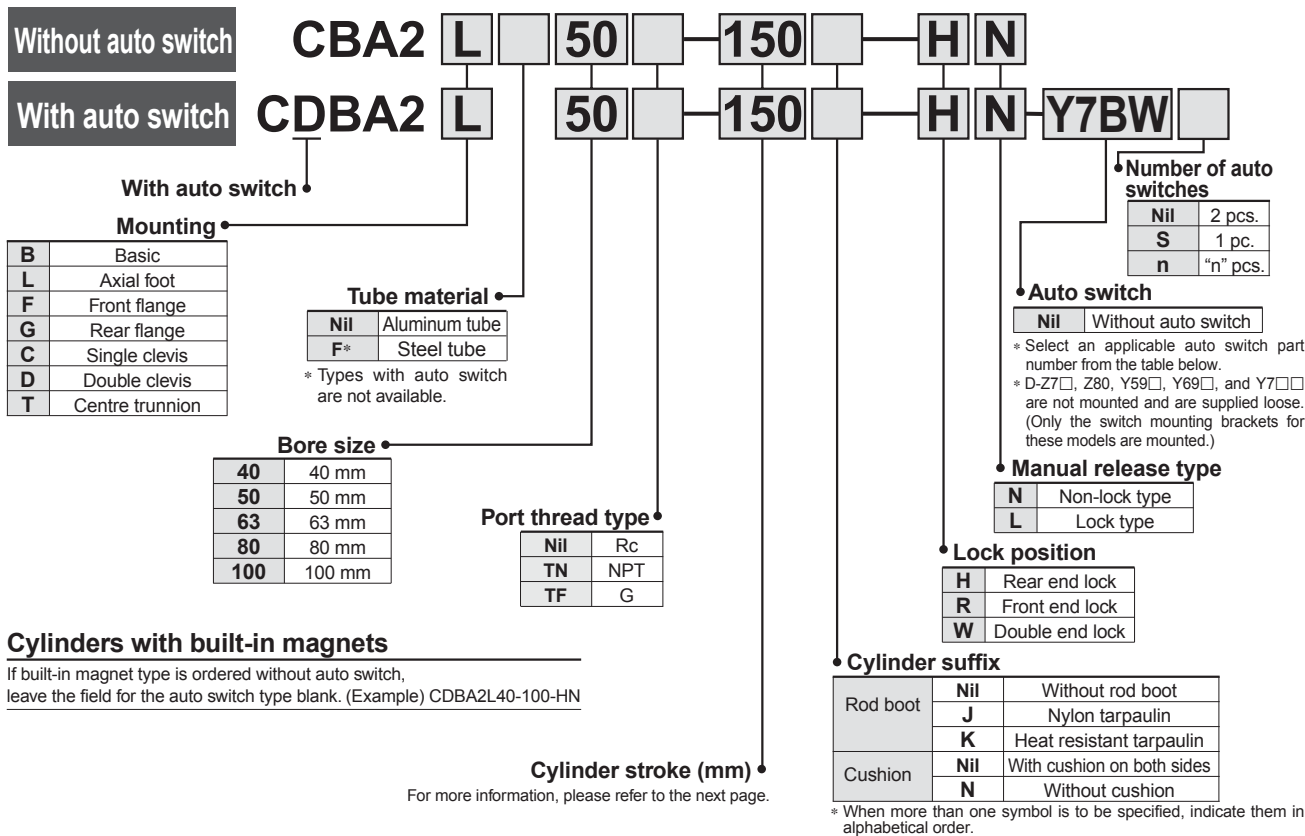

Applicable Auto Switch : Refer to page 5.3 of Best Pneumatics ② for detailed auto switch specifications.

Type	Special function	Electrical entry	Indicator/light	Wiring (output)	Load voltage		Auto switch model	Lead wire length (m)*			Pre-wired connector	Applicable load		
					DC	AC		0.5 (Nil)	3 (L)	5 (Z)				
Reed switch	—	Grommet	Yes	3-wire (NPN equiv.)	—	5 V	—	Z76	●	●	—	—	IC circuit	—
				2-wire	24 V	12 V	100 V	Z73	●	●	●	—	—	Relay, PLC
	Diagnostic indication (2-colour indication)	Grommet	—	—	—	A59W	●	●	—	—	—	—		
Solid state switch	—	Grommet	Yes	3-wire (NPN)	24 V	5 V, 12 V	—	Y59A	●	●	○	○	IC circuit	Relay, PLC
				3-wire (PNP)	—	—	100 V, 200 V	Y7P	●	●	○	○	—	
				2-wire	—	—	100 V, 200 V	J51	●	●	○	—	—	
				2-wire	—	12 V	—	Y59B	●	●	○	○	—	
	Diagnostic indication (2-colour indication)	Grommet	Yes	3-wire (NPN)	—	5 V, 12 V	—	Y7NW	●	●	○	○	IC circuit	
				3-wire (PNP)	—	—	—	Y7PW	●	●	○	○	—	
				2-wire	24 V	12 V	—	Y7BW	●	●	○	○	—	
				2-wire	—	12 V	—	Y7BA	—	●	○	○	—	
Water resistant (2-colour indication)	Grommet	Yes	2-wire	—	5 V, 12 V	—	F59F	●	●	○	○	IC circuit		
With diagnostic output (2-colour indication)			—	—	—	—	—	—	—	—	—			
Latch type with diagnostic output (2-colour indication)	Grommet	Yes	4-wire (NPN)	—	—	—	F5LF	●	●	○	○	—		
Magnetic field resistant (2-colour indication)			2-wire	—	—	—	P5DW	—	●	●	○	—		

* Lead wire length symbol 0.5 m.....Nil (Example) A54
 3 m.....L (Example) A54L
 5 m.....Z (Example) A54Z

* Solid state switches marked with "○" are produced upon receipt of order.

• In addition to the models in the above table, there are some other auto switches that are applicable. For more information, refer to page 15.

Standard type CA2
 Standard type CA2W
 Standard/Non-rotating rod CA2K
 Standard/Non-rotating rod CA2KW
 Low friction CA2□Q
 End lock CBA2
 Air-hydro CA2□H
 Air-hydro CA2W□H
 Auto switch
 Made to order
 Precautions

Series CBA2

Maintains the cylinder's original position even if the air supply is interrupted.

When air is discharged at the stroke end position, the lock engages to maintain the rod in that position.

Same dimensions as those of the standard cylinder (Series CA2)

Non-lock and lock types are standard for manual release.

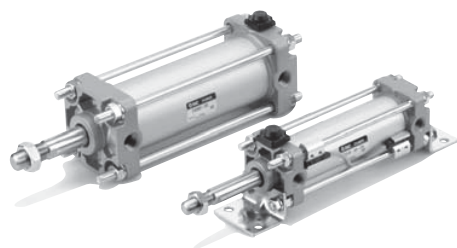

Specifications

Fluid	Air
Proof pressure	1.5 MPa
Maximum operating pressure	1.0 MPa
Minimum operating pressure	0.15MPa*
Ambient and fluid temperature	Without auto switch: -10 to 70°C With auto switch: -10 to 60°C (With no freezing)
Piston speed	50 to 500 mm/s
Cushion	Interchangeable
Thread tolerance	JIS class 2
Stroke length tolerance	To 250 ^{st. +1.0} 251 to 1000 ^{st. +1.4} 1001 to 1500 ^{st. +1.8}
Lubrication	Not required (Non-lube)
Mounting	Basic, Axial foot, Front flange, Rear flange Single clevis, Double clevis, Centre trunnion

* 0.05 MPa except locking parts.

Lock Specifications

Lock position	Rear end, Front end, Double end				
Holding force (max.) (N)	ø40	ø50	ø63	ø80	ø100
	860	1340	2140	3450	5390
Backlash	2 mm or less				
Manual release	Non-lock type, Lock type				

Accessory/ For more information, please refer to page 12.

Accessory	Standard			Option		
	Rod end nut	Clevis pin	Lock release bolt (N type only)	Single knuckle joint	Double knuckle joint (with pin)	Rod boot
Mounting						
Basic	●	—	●	●	●	●
Axial foot	●	—	●	●	●	●
Front flange	●	—	●	●	●	●
Rear flange	●	—	●	●	●	●
Single clevis	●	—	●	●	●	●
* Double clevis	●	●	●	●	●	●
Centre trunnion	●	—	●	●	●	●

* Double clevis and double knuckle joint types are packed with pin, cotter pin and flat washer.



Made to Order Specifications

For more information, please refer to page 64.

Symbol	Specifications/Contents
—XA□	Change of rod end shape
*1 —XB5	Oversized rod
—XB6	Heat resistant (150°C)
*1 —XC4	With heavy duty scraper
*1 —XC6	Piston rod, rod end nut made of stainless steel
—XC7	Tie-rod, cushion valve, and tie-rod nut made of stainless steel
*1 —XC8	Adjustable stroke/Extension adjustment
*2 —XC9	Adjustable stroke/Retraction adjustment
—XC14	Change of trunnion bracket mounting position
—XC15	Change of tie-rod length
—XC22	Fluoro rubber seal
—XC27	Double clevis pin and double knuckle pin made of stainless steel
—XC28	Compact flange made of SS400
—XC29	Double knuckle joint with spring pin
*1 —XC35	With coil scraper

*1: For rear end lock type only

*2: For front end lock type only

Standard Stroke

Bore size (mm)	Standard stroke (mm)
40	25, 50, 75, 100, 125, 150, 175, 200, 250, 300, 350, 400, 450, 500
50, 63	25, 50, 75, 100, 125, 150, 175, 200, 250, 300, 350, 400, 450, 500, 600
80, 100	25, 50, 75, 100, 125, 150, 175, 200, 250, 300, 350, 400, 450, 500, 600, 700

* Types with auto switch have different minimum strokes. Please refer to page 13.

Rod Boot Material

Symbol	Rod boot materials	Max. ambient temperature
J	Nylon tarpaulin	70°C
K	Neoprene cross	110°C*

* Maximum ambient temperature for the rod boot itself.

Minimum Stroke for Auto Switch Mounting

⚠ Caution

① The minimum stroke for mounting varies with the auto switch type and mounting type of the cylinder. In particular, the centre trunnion type needs careful attention. (For more information, please refer to page 13.)

Weight/Aluminum Tube (Steel tube)

(kg)

Bore size (mm)		40	50	63	80	100
Basic weight	Basic	0.89 (0.94)	1.36 (1.40)	2.00 (2.04)	3.48 (3.63)	4.87 (5.07)
	Axial foot	1.08 (1.13)	1.58 (1.62)	2.34 (2.38)	4.15 (4.30)	5.86 (6.06)
	Flange	1.26 (1.30)	1.81 (1.86)	2.79 (2.84)	4.93 (5.08)	6.79 (6.99)
	Single clevis	1.12 (1.17)	1.70 (1.74)	2.63 (2.67)	4.59 (4.74)	6.65 (6.86)
	Double clevis	1.16 (1.21)	1.79 (1.84)	2.79 (2.83)	4.88 (5.03)	7.17 (7.38)
	Trunnion	1.25 (1.35)	1.84 (1.94)	2.80 (3.00)	5.03 (5.32)	7.15 (7.54)
Additional weight by each 50 mm stroke	All mounting brackets (except for steel tube trunnion)	0.22 (0.28)	0.28 (0.35)	0.37 (0.43)	0.52 (0.70)	0.65 (0.87)
	Steel tube trunnion	(0.36)	(0.46)	(0.65)	(0.86)	(1.07)
Accessory	Single knuckle	0.23	0.26	0.26	0.60	0.83
	Double knuckle (with pin)	0.37	0.43	0.43	0.87	1.27

* Values inside the parentheses are those for the steel tube type.

Lock Unit Additional Weight

(kg)

Bore size (mm)		40	50	63	80	100
Manual release Non-lock type (N)	Rear end lock (H)	0.02	0.03	0.03	0.10	0.12
	Front end lock (R)	0.02	0.02	0.02	0.07	0.06
	Double end lock (W)	0.04	0.05	0.05	0.17	0.18
Manual release lock type (L)	Rear end lock (H)	0.04	0.05	0.05	0.13	0.15
	Front end lock (R)	0.04	0.04	0.04	0.10	0.09
	Double end lock (W)	0.08	0.09	0.09	0.23	0.24

Calculation example: **CBA2L40-100-HN**

- Basic weight 1.08kg (ø40 foot type)
 - Additional weight ... 0.22/50st
 - Lock weight 0.02 kg
 - Cylinder stroke 100st
- (Rear end lock, Manual release, Non-lock)
- $1.08 + 0.22 \times 100/50 + 0.02 = 1.54 \text{ kg}$

The minimum stroke for auto switch mounting, proper auto switch mounting position and height, operating range, applicable auto switches, auto switch mounting brackets and their part numbers, and bracket part numbers are the same as those for the double acting single rod type of Series CA2.

Series CBA2

Construction

Rear end lock

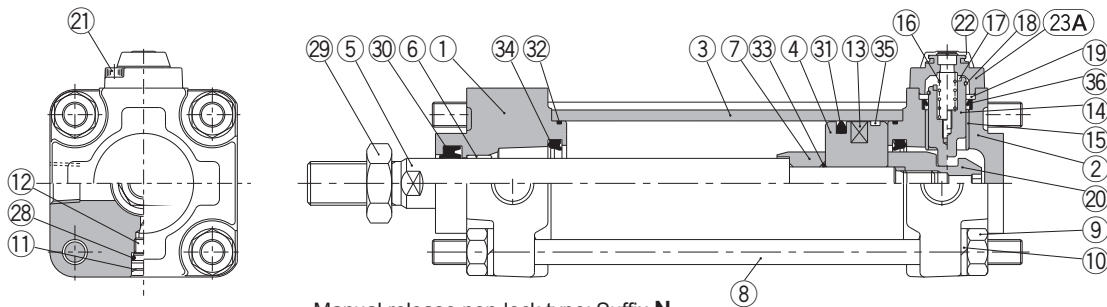

Manual release non-lock type: Suffix N

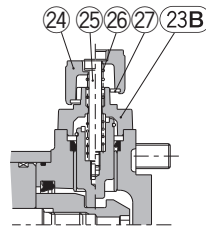

Manual release lock type: Suffix L

Parts List

No.	Description	Material	Note
1	Rod cover	Aluminum casting	Metallic painted
2	Head cover	Aluminum casting	Metallic painted
3	Cylinder tube	Aluminum alloy	Hard anodized
4	Piston	Aluminum alloy	Chromated
5	Piston rod	Carbon steel	Hard chromium electroplated
6	Bushing	Lead-bronze casting	
7	Cushion ring A	Rolled steel	Electroless nickel plated
8	Tie-rod	Carbon steel	Corrosion resistant chromated
9	Tie-rod nut	Rolled steel	Nickel plated
10	Spring washer	Steel wire	Chromated
11	Snap ring	Spring steel	
12	Cushion valve	Steel wire	Nickel plated
13	Rubber magnet*	NBR	With auto switch*
14	Lock piston	Carbon steel	Quench hard chrome plated
15	Lock bushing	Lead-bronze casting	
16	Lock spring	Stainless steel	
17	Bumper	Urethane	
18	C-ring	Steel wire	Zinc chromated
19	Seal retainer	Rolled steel	Zinc chromated
20	Cushion ring nut	Chromium molybdenum steel	Quench hard chrome plated
21	Hexagon socket head cap screw	Chromium molybdenum steel	Black zinc chromated
22	Rubber cap	Chloroprene rubber	
23A	Cap A	Aluminum casting	Black coated
23B	Cap B	Carbon steel	Black coated, Tuffride

No.	Description	Material	Note
24	M/O knob	Die-cast zinc	Black coated
25	M/O bolt	Chromium molybdenum steel	Black zinc chromated
26	M/O spring	Steel wire	Zinc chromated
27	Stopper ring	Carbon steel	Zinc chromated
28	Cushion valve seal	NBR	
29	Rod end nut	Rolled steel	Nickel plated
30	Rod seal	NBR	
31	Piston seal	NBR	
32	Cylinder tube gasket	NBR	
33	Piston gasket	NBR	
34	Cushion seal	NBR	
35	Wear ring	Resin	
36	Lock piston seal	NBR	

Replacement Parts / Seal Kits

Bore size (mm)	Seal kit No.		Content
	Single end lock	Double end lock	
40	MBB40-PS	MBB40-PS-W	Consists of numbers 30, 31, 32, 34, and 36 above.
50	MBB50-PS	MBB50-PS-W	
63	MBB63-PS	MBB63-PS-W	
80	MBB80-PS	MBB80-PS-W	
100	MBB100-PS	MBB100-PS-W	

The seal kits consist of items 30, 31, 32, 34 and 36.

Please order them by using the seal kit number corresponding to each bore size.

End Lock Cylinder *Series CBA2*

Basic (Dimensions are common to rear end lock, front end lock and double end lock types.)

Rear end lock: **CBA2B** **Bore size** **Stroke** **-HN** Manual release (non-lock type)
: Suffix **N**

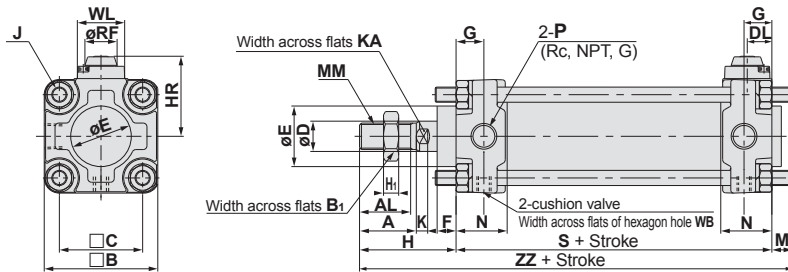

Manual release (lock type)
: Suffix **L**

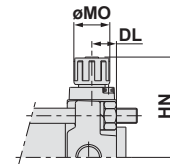

Front lock: **CBA2B** **Bore size** **Stroke** **-RN** Manual release (non-lock type)
: Suffix **N**

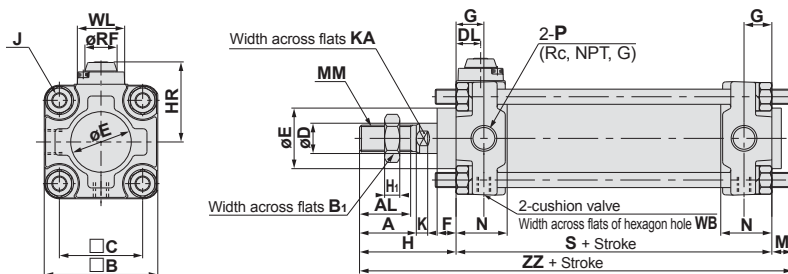

Manual release (lock type)
: Suffix **L**

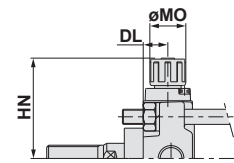

Double lock: **CBA2B** **Bore size** **Stroke** **-WN** Manual release (non-lock type)
: Suffix **N**

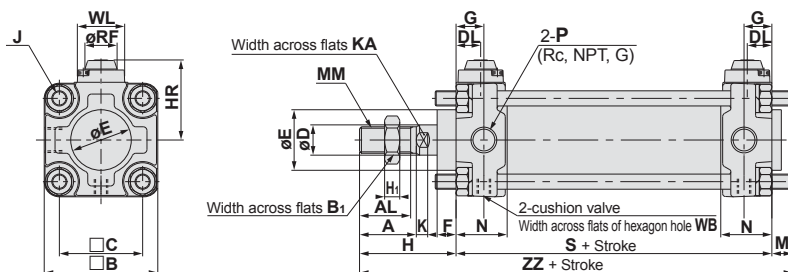

Manual release (lock type)
: Suffix **L**

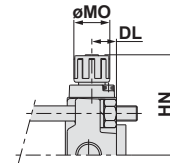

With rod boot

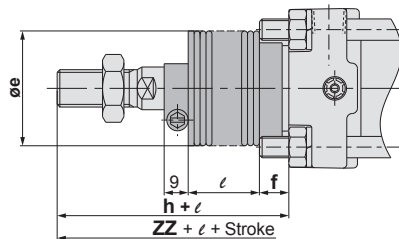

Bore size (mm)	Stroke range	A	AL	B	B ₁	C	D	DL	E	F	G	H	H ₁	HR	HN (MAX)	J	K	KA	M	MM	MO	N	P	RF	S	WB	WL	ZZ
40	up to 500	30	27	60	22	44	16	13	32	10	15	51	8	42.3	56	M8	6	14	11	M14 x 1.5	19	27	1/4	17	84	2.5	25	146
50	up to 600	35	32	70	27	52	20	13	40	12	17	58	11	47.3	61	M8	7	18	11	M18 x 1.5	19	30	3/8	17	90	2.5	25	159
63	up to 600	35	32	85	27	64	20	15.5	40	10	17	58	11	54.8	68.5	M10 x 1.25	7	18	14	M18 x 1.5	19	31	3/8	17	98	4	25	170
80	up to 750	40	37	102	32	78	25	18.5	52	14	21	71	13	65.8	80.5	M12	11	22	17	M22 x 1.5	23	37	1/2	21	116	4	40	204
100	up to 750	40	37	116	41	92	30	20	52	14	21	72	16	72.8	87.5	M12	11	26	17	M26 x 1.5	23	40	1/2	21	126	4	40	215

* For more information about the rod end nut and accessories, please refer to page 12.

With Rod Boot

Bore size (mm)	Stroke range (mm)	e	f	h	l	ZZ
40	20 to 500	43	11.2	59	1/4 stroke	154
50	20 to 600	52	11.2	66	1/4 stroke	167
63	20 to 600	52	11.2	66	1/4 stroke	178
80	20 to 750	65	12.5	80	1/4 stroke	213
100	20 to 750	65	14	81	1/4 stroke	224

Dimensions of the mounting brackets are the same as those of the standard double acting single rod type. Please refer to pages 7 to 10.

Standard type
CA2

Standard type
CA2W

Standard/Non-rotating rod
CA2K

Standard/Non-rotating rod
CA2KW

Low friction
CA2Q

End lock
CBA2

Air-hydro
CA2H

Air-hydro
CA2WH

Auto switch

Made to order

Precautions

⚠ Specific Product Precautions

Be sure to read before handling. Please refer to pages 72 to 79 for safety instructions and common precautions.

Use the Recommended Pneumatic Circuit.

⚠ Caution

They are required to engage and disengage the locks correctly.

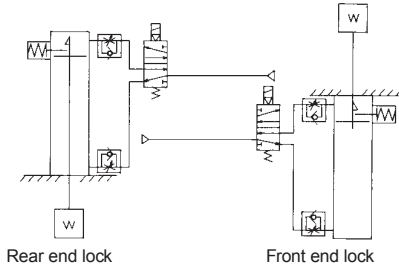

Operation

⚠ Caution

- ① **Do not use a 3 position solenoid valve.**
Avoid using this cylinder in combination with a 3 position solenoid valve (particularly the closed centre metal seal type). If air pressure becomes sealed inside the port on the side that contains the lock mechanism, the lock will not engage. Even if the lock is engaged at first, the air that leaks from the solenoid valve could enter the cylinder and cause the lock to disengage as time elapses.
- ② **Back pressure is required when releasing the lock.**
Before starting, make sure that air is supplied to the side that is not equipped with a lock mechanism as shown in the diagram above (or the side on which the piston rod is unlocked, if both sides are equipped with a lock). Otherwise, the lock may not disengage.
- ③ **Release the lock when mounting or adjusting the cylinder.**
The lock may not disengage if the cylinder is installed with its lock engaged.
- ④ **Operate with a load ratio of 50% or less.**
The lock may not disengage or may become damaged if the load exceeds 50%.
- ⑤ **Do not operate multiple synchronized cylinders.**
Avoid applications in which two or more end lock cylinders are synchronized to move one work piece, as one of the cylinder locks may not be disengaged when required.
- ⑥ **Use a speed controller with meter-out control.**
If operated under meter-in control, the lock may not disengage.
- ⑦ **Be sure to operate completely to the cylinder stroke end on the side with the lock.**
The lock may not engage or disengage if the piston in the cylinder has not reached the stroke end.

Operating Pressure

⚠ Caution

- ① Supply air pressure of 0.15 MPa or higher to the port on the side that has the lock mechanism, as it is necessary for disengaging the lock.

Exhaust Speed

⚠ Caution

- ① When the pressure on the side with the lock mechanism drops to 0.05 MPa or below, the lock engages automatically. If the piping on the side with the lock mechanism is thin and long, or if the speed controller is away from the cylinder port, the lock engagement may take some due to decline of the exhaust speed. The same result will be caused by clogging of the silencer installed at the EXH port of the solenoid valve.

Relation to Cushion

⚠ Caution

- ① When the cushion valve on the side with the lock mechanism is fully closed or almost closed, the piston rod may not be able to reach the stroke end, resulting in lock engagement failure. Furthermore, if the lock becomes engaged while the cushion valve is almost fully closed, it may become impossible to be disengaged. Therefore, the cushion valve must be adjusted properly.

Releasing the Lock

⚠ Caution

- ① To disengage the lock, make sure to supply air pressure to the port on the side without a lock mechanism, thus preventing the load from being applied to the lock mechanism. (Refer to the recommended air pressure circuit.) If the lock is disengaged, while the port on the side without a lock mechanism is in the exhausted state and the load is being applied to the lock mechanism, undue force may be applied to the lock mechanism, causing the lock mechanism to be damaged. Also, it could be extremely dangerous, because the piston rod could move suddenly.

Manual Release

⚠ Caution

- ① **Non-lock type manual release**
Insert the bolt, which is provided as an accessory part, through the rubber cap (it is not necessary to remove the rubber cap). Screw the bolt into the lock piston and pull the bolt to disengage the lock. Releasing the bolt will re-engage the lock.
The bolt size, pulling force, and the stroke are listed below.

Bore size (mm)	Thread size	Pulling force	Stroke (mm)
40, 50, 63	M3 x 0.5 x 30 or more	10N	3
80, 100	M5 x 0.8 x 40 or more	24.5N	3

- * Remove the bolt for normal operation.
- * It can cause lock malfunction or faulty release.

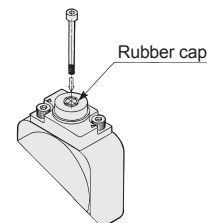

② Manual release lock type

- Push the M/O knob and turn it 90° counterclockwise. The lock disengages when the ▲ mark on the cap is aligned with the ▼ OFF mark on the M/O knob (and the lock will remain disengaged). To engage the lock, push the M/O knob all the way in and turn it 90° clockwise to align the ▲ mark on the cap with the ▼ ON mark on the M/O knob. At this time, make sure that the knob stops by clicking into place. Failure to click it into place properly can cause the lock to disengage.

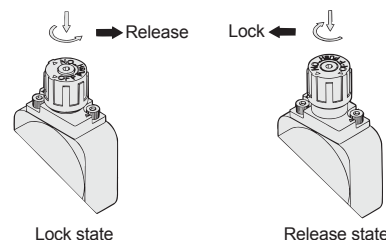

Air-Hydro Cylinder/Double Acting Single Rod

Series CA2□H

Air-hydro Type/ø40, ø50, ø63, ø80, ø100

How to Order

Without auto switch

CA2 **L** □ **H** **50** □ **100** **J**

With auto switch

CDA2 **L** □ **H** **50** □ **100** **J** **Y7BW** □

Mounting

B	Basic
L	Axial foot
F	Front flange
G	Rear flange
C	Single clevis
D	Double clevis
T	Centre trunnion

Tube material

Nil	Aluminum tube
F*	Steel tube

* Not available with auto switch.

Hydro type

Nil	Rc
TN	NPT
TF	G

Bore size

40	40 mm
50	50 mm
63	63 mm
80	80 mm
100	100 mm

Port thread type

Nil	Rc
TN	NPT
TF	G

Number of auto switches

Nil	2 pcs.
S	1 pc.
3	3 pcs.
n	"n" pcs.

Auto switch

Nil	Without auto switch
-----	---------------------

* Select an applicable auto switch model from the table below.
 * D-Z7□, Z80, Y59□, Y69□, and Y7□ are not mounted and are supplied loose. (Only the switch mounting brackets for these models are mounted.)

Cylinder suffix

Nil	Without rod boot
J	Nylon tarpaulin
K	Heat resistant tarpaulin

Cylinders with built-in magnets

If built-in magnet type is ordered without auto switch, leave the field for the auto switch type blank.
 (Example) CDA2LH40-100

Cylinder stroke (mm)

For more information, please refer to the next page.

Applicable Auto Switch : Refer to page 5.3 of Best Pneumatics ② for detailed auto switch specifications.

Type	Special function	Electrical entry	Indicator light	Wiring (output)	Load voltage		Auto switch model	Lead wire length (m)*			Pre-wired connector	Applicable load			
					DC	AC		0.5 (Nil)	3 (L)	5 (Z)					
Reed switch	—	Grommet	Yes	3-wire (NPN equiv.)	—	5 V	Z76	●	●	—	—	IC circuit	—		
				2-wire	24 V	12 V	100 V	Z73	●	●	●	—	—	Relay, PLC	
	—	100 V, 200 V	A54			●	●	●	—						
Diagnostic indication (2-colour indication)	Grommet	—	—	—	—	A59W	●	●	—	—	—	—			
Solid state switch	—	Grommet	Yes	3-wire (NPN)	24 V	5 V, 12 V	—	Y59A	●	●	○	○	IC circuit	Relay, PLC	
				3-wire (PNP)				Y7P	●	●	○	○			
				2-wire	—	100 V, 200 V	J51	●	●	○	○				
							Y59B	●	●	○	○				
	Diagnostic indication (2-colour indication)	Grommet	Yes	—	3-wire (NPN)	24 V	5 V, 12 V	—	Y7NW	●	●	○	○		IC circuit
					3-wire (PNP)				Y7PW	●	●	○	○		
					2-wire	24 V	12 V	—	Y7BW	●	●	○	○		—
									Y7BA	—	●	○	○		
	Water resistant (2-colour indication)	Grommet	Yes	—	4-wire (NPN)	24 V	5 V, 12 V	—	F59F	●	●	○	○		IC circuit
	With diagnostic output (2-colour indication)								F5LF	●	●	○	○		
Latch type with diagnostic output (2-colour indication)	—								—	—	—	—			
Magnetic field resistant (2-colour indication)	Grommet	Yes	—	2-wire	—	—	—	P5DW	—	●	●	○	—		

* Lead wire length symbol 0.5 m.....Nil (Example) A54
 3 m.....L (Example) A54L
 5 m.....Z (Example) A54Z

* Solid state switches marked with "○" are produced upon receipt of order.

In addition to the models in the above table, there are some other auto switches that are applicable. For more information, refer to page 15.

Standard type CA2

Standard type CA2W

Standard/Non-rotating rod CA2K

Standard/Non-rotating rod CA2KW

Low friction CA2Q

End lock CBA2

Air-hydro CA2H

Air-hydro CA2W□H

Auto switch

Made to order

Precautions

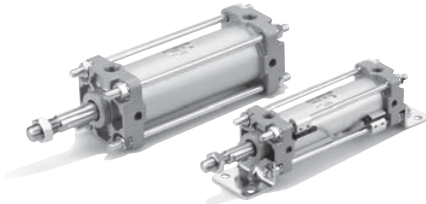

JIS symbol

Double acting type

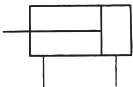

Specific Product Precautions

Setting

Caution

- ① Do not use the cylinder near fire or on equipment or machinery whose ambient temperature exceeds 60°C.

Since the air-hydro cylinder uses flammable hydraulic fluid, there is danger of potential fire.

Selection

Caution

- ① Keep the air-hydro cylinder load at 50% or less than the theoretical output.

For the air-hydro cylinder to achieve performance that is close to that of the hydraulic cylinder in constant-speed operation and stopping accuracy, the load must be kept at 50% or less than theoretical output.

Specifications

Type	Air-hydro type
Fluid	Turbine oil
Action	Double acting
Proof pressure	1.5 MPa
Maximum operating pressure	1.0 MPa
Ambient and fluid temperature	5 to 60°C
Minimum operating pressure	0.1MPa
Piston speed	0.5 to 300 mm/s
Cushion	Without
Thread tolerance	JIS class 2
Stroke length tolerance	To 250 st : $^{+1.0}_0$ 251 to 1.000 st : $^{+1.4}_0$ 1.001 to 1.500 st : $^{+1.8}_0$
Mounting	Basic, Foot, Front flange, Rear flange Single clevis, Double clevis, Centre trunnion

Standard Stroke/

In case of a type with auto switch, please also refer to the table of minimum strokes for auto switch mounting on page 13.

Bore size (mm)	Standard stroke (mm) ^{Note)}	Long stroke (L and F only)
40	25, 50, 75, 100, 125, 150, 175, 200, 250, 300, 350, 400, 450, 500	800
50, 63	25, 50, 75, 100, 125, 150, 175, 200, 250, 300, 350, 400, 500, 600	1200
80, 100	25, 50, 75, 100, 125, 150, 175, 200, 250, 300, 350, 400, 450, 500, 600, 700	ø80: 1400 ø100: 1500

Note) Intermediate strokes not listed above are produced upon receipt of order.

Rod Boot Material

Symbol	Rod boot material	Max. ambient temperature
J	Nylon tarpaulin	70°C
K	Heat resistant tarpaulin	110°C*

* Maximum ambient temperature for the rod boot itself.

Accessory

Mounting		Basic	Axial foot	Front flange	Rear flange	Single clevis	Double clevis	Centre trunnion
Standard equipment	Rod end nut	●	●	●	●	●	●	●
	Clevis pin	—	—	—	—	—	●	—
Options	Single knuckle joint	●	●	●	●	●	●	●
	Double knuckle joint (with pin)	●	●	●	●	●	●	●
	With rod boot	●	●	●	●	●	●	●

Minimum Stroke for Auto Switch Mounting

Caution

- ① The minimum stroke for mounting varies with the auto switch type and mounting type of the cylinder. In particular, the centre trunnion type needs careful attention. (For more information, please refer to page 13.)

Air-Hydro Cylinder/Double Acting Single Rod **Series CA2□H**

Standard type
CA2

Standard type
CA2W

Standard/Non-rotating rod
CA2K

Standard/Non-rotating rod
CA2KW

Low friction
CA2□Q

End lock
CBA2

Air-hydro
CA2□H

Air-hydro
CA2W□H

Auto switch

Made to order

Precautions

Weight/Aluminum Tube (Steel Tube)

Bore size (mm)		40	50	63	80	100
Basic weight	Basic	0.89 (0.94)	1.36 (1.40)	2.00 (2.04)	3.48 (3.63)	4.87 (5.07)
	Axial foot	1.08 (1.13)	1.58 (1.62)	2.34 (2.38)	4.15 (4.30)	5.86 (6.06)
	Flange	1.26 (1.30)	1.81 (1.86)	2.79 (2.84)	4.93 (5.08)	6.79 (6.99)
	Single clevis	1.12 (1.17)	1.70 (1.74)	2.63 (2.67)	4.59 (4.74)	6.65 (6.86)
	Double clevis	1.16 (1.21)	1.79 (1.83)	2.79 (2.83)	4.88 (5.03)	7.17 (7.38)
	Trunnion	1.25 (1.35)	1.84 (1.94)	2.80 (3.00)	5.03 (5.32)	7.15 (7.54)
Additional weight by each 50 mm stroke	All mounting brackets (except for steel tube trunnion)	0.22 (0.28)	0.28 (0.35)	0.37 (0.43)	0.52 (0.70)	0.65 (0.87)
	Steel tube trunnion	(0.36)	(0.46)	(0.65)	(0.86)	(1.07)
Accessories	Single knuckle	0.23	0.26	0.26	0.60	0.83
	Double knuckle (with pin)	0.37	0.43	0.43	0.87	1.27

Calculation example: CA2LH40-100 (axial foot type, ø40, 100st)

- Basic weight 1.08 kg
- Additional weight 0.22/50st
- Cylinder stroke 100st

$$1.08 + 0.22 \times 100/50 = 1.52 \text{ kg}$$

* Values inside the parentheses are those for the steel tube type.

Auto Switch Mounting Bracket Part No.

Auto switch model	Bore size (mm)				
	40	50	63	80	100
D-A5□/A6□ D-A59W D-F5□/J5□ D-F5□W/J59W D-F5□F/F5NTL	BT-04	BT-04	BT-06	BT-08	BT-08
*** D-A3□/A44 *** D-G39/K39	BD1-04M	BD1-05M	BD1-06M	BD1-08M	BD1-10M
*** D-B5□/B64 *** D-B59W *** D-G5□/K59 *** D-G5□W/K59W *** D-G59F *** D-G5NTL	BA-04	BA-05	BA-06	BA-08	BA-10
* D-A3□C/A44C * D-G39C/K39C	BA3-040	BA3-050	BA3-063	BA3-080	BA3-100
D-Z7□/Z80 D-Y59□/Y69□ D-Y7P/Y7PV D-Y7□W D-Y7□WV D-Y7BAL	BA4-040	BA4-040	BA4-063	BA4-080	BA4-080
D-P5DWL	BAP2-040	BAP2-040	BAP2-063	BAP2-080	BAP2-080

* Mounting brackets are attached to models D-A3□C, A44C, G39C and K39C.

When placing an order, indicate one of the following part numbers according to the cylinder size.

(Example) ø40 ... D-A3□C-4, ø80 ... D-A3□C-8
 ø50 ... D-A3□C-5, ø100 ... D-A3□C-10
 ø63 ... D-A3□C-6,

When other brackets are ordered separately, order by the above part numbers.

** Stainless steel mounting screw kit

The following stainless steel mounting screw kits (including set screws) are available if the operating environment requires. (The mounting bracket and band are not included and must be ordered separately.)

BBA1: D-A5/A6/F5/J5
 BBA3: D-B5/B6/G5/K5

When a switch model D-F5BAL or G5BAL is mounted on the cylinder at the time of shipment, the above stainless steel screws are used. When the switch is shipped alone, BBA1 or BBA3 is attached.

*** Series CDA2 models vary in the thickness of the cylinder tube wall. In cases where the band mount type is used as an applicable auto switch, select the part number of the new band referring to page 79 whenever the cylinder model is changed.

The minimum stroke for auto switch mounting, proper auto switch mounting position and height, operating range, applicable auto switches, auto switch mounting brackets and their part numbers, and bracket part numbers are the same as those for the double acting single rod type of Series CA2.

Construction

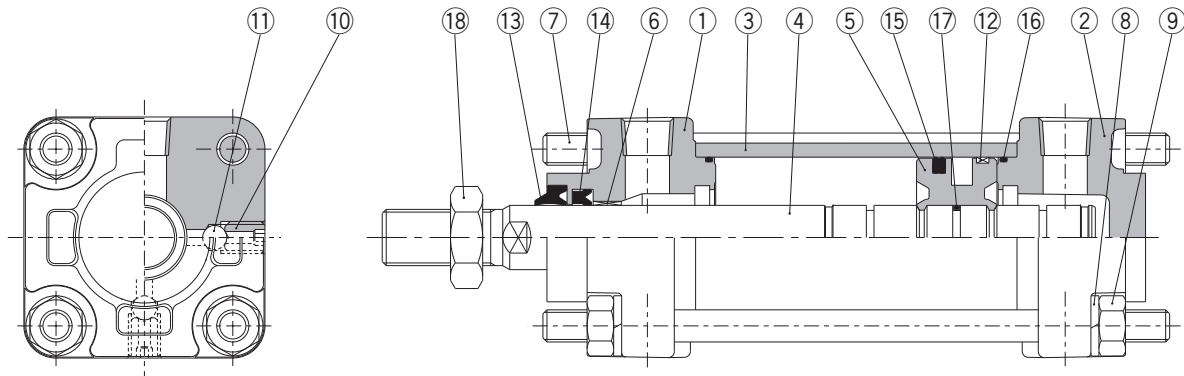

Parts List

No.	Description	Material	Note
1	Rod cover	Aluminum alloy	Metallic painted
2	Head cover	Aluminum alloy	Metallic painted
3	Cylinder tube	Aluminum alloy	Hard anodized
4	Piston rod	Carbon steel	Hard chromium electroplated
5	Piston	Aluminum alloy	Chromated
6	Bushing	Lead-bronze casting	
7	Tie-rod	Carbon steel	Corrosion resistant chromated
8	Spring washer	Rolled steel	Chromated
9	Tie-rod nut	Rolled steel	Nickel plated
10	Air release valve	Chromium molybdenum steel	Black zinc chromated
11	Check ball	Bearing steel	
12	Wear ring	Resin	
13	Scraper	NBR	
14	Rod seal	NBR	
15	Piston seal	NBR	
16	Cylinder tube gasket	NBR	
17	Piston gasket	NBR	
18	Rod end nut	Rolled steel	Nickel plated

Replacement Parts: Seal Kits

Bore size (mm)	Seal kit No.	Content
	Air-hydro type	
40	CA2H40A-PS	Consists of numbers 14, 15, and 16 above.
50	CA2H50A-PS	
63	CA2H63A-PS	
80	CA2H80A-PS	
100	CA2H100A-PS	

Air-Hydro Cylinder/Double Acting Single Rod **Series CA2□H**

Standard type
CA2

Standard type
CA2W

Standard/Non-rotating rod
CA2K

Standard/Non-rotating rod
CA2KW

Low friction
CA2□Q

End lock
CBA2

Air-hydro
CA2□H

Air-hydro
CA2W□H

Auto switch

Made to order

Precautions

Basic/CA2BH

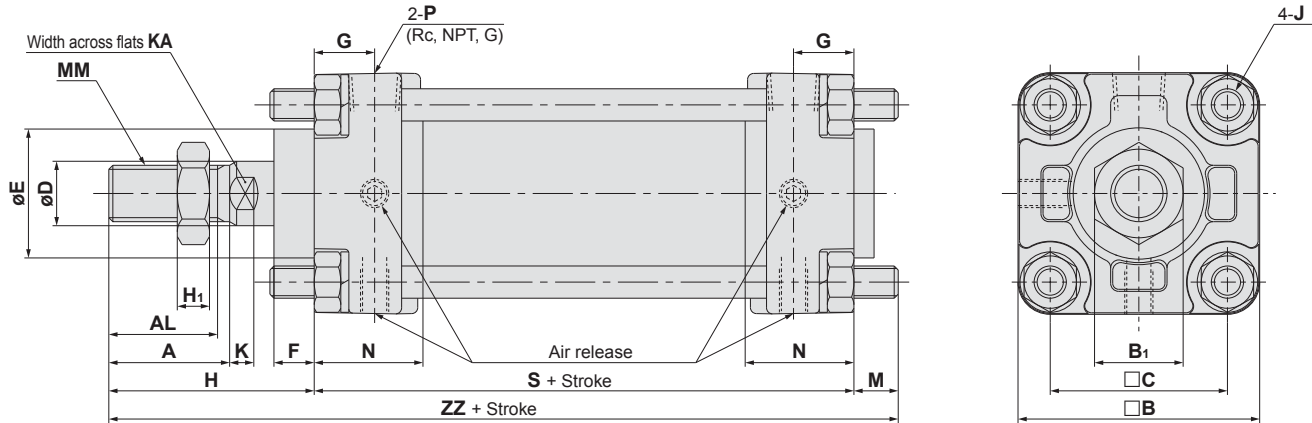

With rod boot

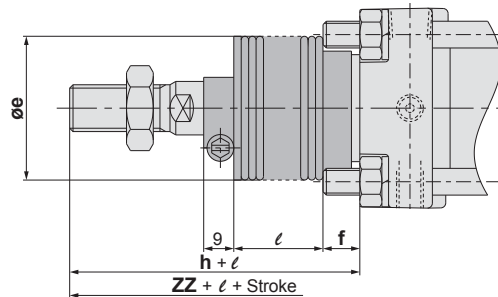

Bore size (mm)	Stroke range (mm)		A	AL	B	B ₁	C	D	E	F	G	H ₁	J	K	KA	M	MM	N	P
	Without rod boot	With rod boot																	
40	up to 500	20 to 500	30	27	60	22	44	16	32	10	15	8	M8	6	14	11	M14 x 1.5	27	1/4
50	up to 600	20 to 600	35	32	70	27	52	20	40	10	17	11	M8	7	18	11	M18 x 1.5	30	3/8
63	up to 600	20 to 600	35	32	85	27	64	20	40	10	17	11	M10 x 1.25	7	18	14	M18 x 1.5	31	3/8
80	up to 750	20 to 750	40	37	102	32	78	25	52	14	21	13	M12	10	22	17	M22 x 1.5	37	1/2
100	up to 750	20 to 750	40	37	116	41	92	30	52	14	21	16	M12	10	26	17	M26 x 1.5	40	1/2

Bore size (mm)	S	Without rod boot		With rod boot				
		H	ZZ	e	f	h	ℓ	ZZ
40	84	51	146	43	11.2	59	1/4 stroke	154
50	90	58	159	52	11.2	66	1/4 stroke	167
63	98	58	170	52	11.2	66	1/4 stroke	178
80	116	71	204	65	12.5	80	1/4 stroke	213
100	126	72	215	65	14	81	1/4 stroke	224

Series CA2□H

Axial Foot/CA2LH

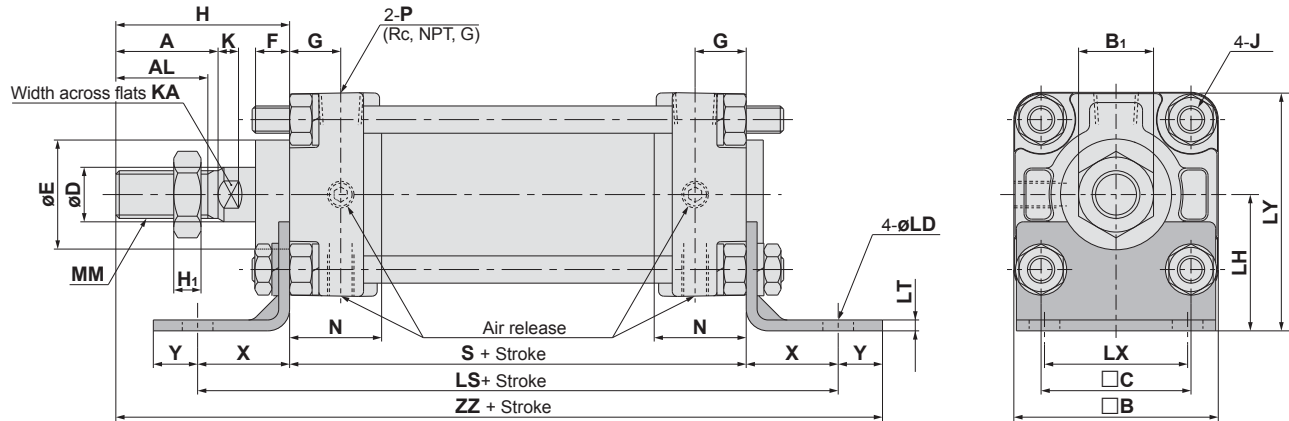

Long stroke

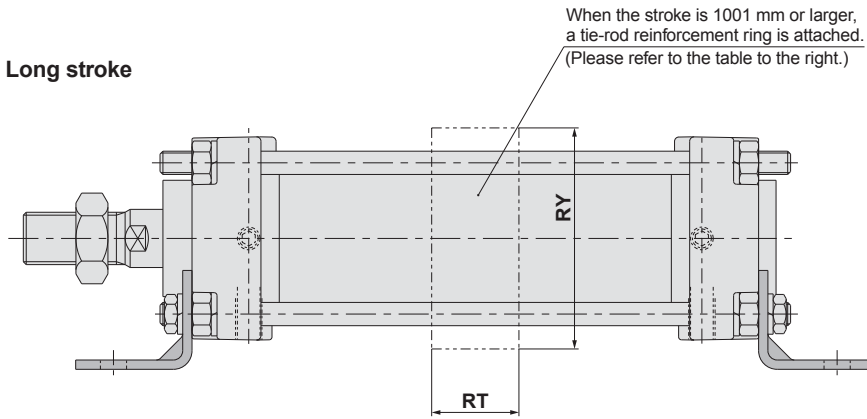

For Long Strokes (mm)

Tube size (mm)	Stroke range (mm)	RT	RY
40	501 to 800	—	—
	1601 to 1000	—	—
50	1001 to 1200	30	76
	601 to 1000	—	—
63	1001 to 1200	40	92
	751 to 1000	—	—
80	1001 to 1400	45	112
	751 to 1000	—	—
100	1001 to 1500	50	136
	—	—	—

With rod boot

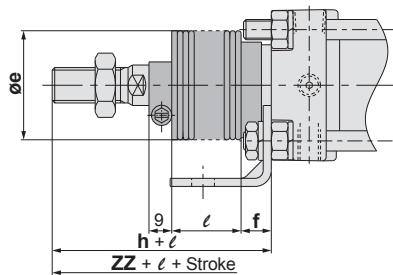

(mm)

Bore size (mm)	Stroke range (mm)		A	AL	B	B ₁	C	D	E	F	G	H ₁	J	K	KA	LD	LH	LS	LT
	Without rod boot	With rod boot																	
40	up to 500	20 to 500	30	27	60	22	44	16	32	10	15	8	M8	6	14	9	40	138	3.2
50	up to 600	20 to 600	35	32	70	27	52	20	40	10	17	11	M8	7	18	9	45	144	3.2
63	up to 600	20 to 600	35	32	85	27	64	20	40	10	17	11	M10 x 1.25	7	18	11.5	50	166	3.2
80	up to 750	20 to 750	40	37	102	32	78	25	52	14	21	13	M12	10	22	13.5	65	204	4.5
100	up to 750	20 to 750	40	37	116	41	92	30	52	14	21	16	M12	10	26	13.5	75	212	6

Bore size (mm)	LX	LY	MM	N	P	S	X	Y	Without rod boot		With rod boot				
									H	ZZ	e	f	h	l	ZZ
40	42	70	M14 x 1.5	27	1/4	84	27	13	51	175	43	11.2	59	1/4 stroke	183
50	50	80	M18 x 1.5	30	3/8	90	27	13	58	188	52	11.2	66	1/4 stroke	196
63	59	93	M18 x 1.5	31	3/8	98	34	16	58	206	52	11.2	66	1/4 stroke	214
80	76	116	M22 x 1.5	37	1/2	116	44	16	71	247	65	12.5	80	1/4 stroke	256
100	92	133	M26 x 1.5	40	1/2	126	43	17	72	258	65	14.0	81	1/4 stroke	267

Standard type CA2
 Standard type CA2W
 Standard/Non-rotating rod CA2K
 Standard/Non-rotating rod CA2KW
 Low friction CA2□Q
 End lock CBA2
 Air-hydro CA2□H
 Air-hydro CA2W□H
 Auto switch
 Made to order
 Precautions

Front Flange/CA2FH

With rod boot

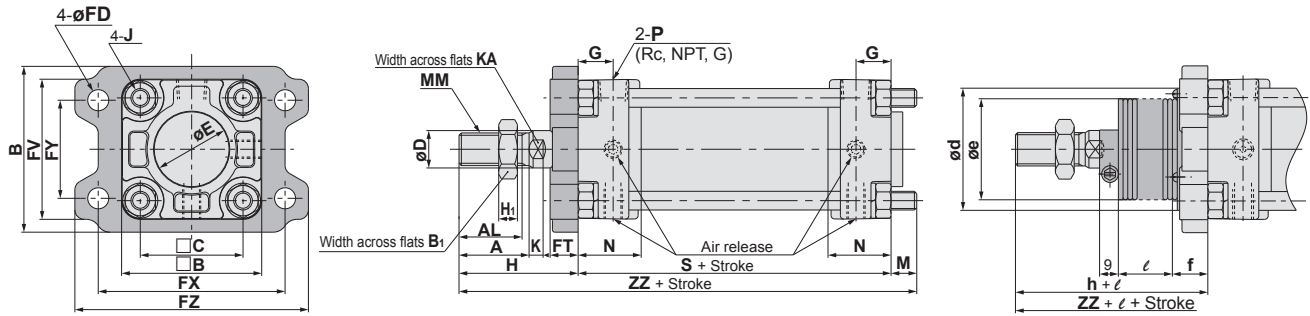

Bore size (mm)	Stroke range (mm)		Long stroke range (mm)*	A	AL	□B	B	B ₁	□C	D	E	FV	FD	FT	FX	FY	FZ	G	H ₁	J
	Without rod boot	With rod boot		Without rod boot	With rod boot	Without rod boot	With rod boot	Without rod boot	With rod boot	Without rod boot	With rod boot	Without rod boot	With rod boot	Without rod boot	With rod boot	Without rod boot	With rod boot	Without rod boot	With rod boot	Without rod boot
40	up to 500	20 to 500	501 to 800	30	27	71	60	22	44	16	32	60	9	12	80	42	100	15	8	M8
50	up to 600	20 to 600	601 to 1000	35	32	81	70	27	52	20	40	70	9	12	90	50	110	17	11	M8
63	up to 600	20 to 600	601 to 1000	35	32	101	85	27	64	20	40	86	11.5	15	105	59	130	17	11	M10 x 1.25
80	up to 750	20 to 750	751 to 1000	40	37	119	102	32	78	25	52	102	13.5	18	130	76	160	21	13	M12
100	up to 750	20 to 750	751 to 1000	40	37	133	116	41	92	30	52	116	13.5	18	150	92	180	21	16	M12

Bore size (mm)	K	KA	M	MM	N	P	S	Without rod boot		With rod boot					
								H	ZZ	d*	e	f	h	ℓ	ZZ
40	6	14	11	M14 x 1.5	27	1/4	84	51	146	52	43	15	59	1/4 stroke	154
50	7	18	11	M18 x 1.5	30	3/8	90	58	159	58	52	15	66	1/4 stroke	167
63	7	18	14	M18 x 1.5	31	3/8	98	58	170	58	52	17.5	66	1/4 stroke	178
80	10	22	17	M22 x 1.5	37	1/2	116	71	204	80	65	21.5	80	1/4 stroke	213
100	10	26	17	M26 x 1.5	40	1/2	126	72	215	80	65	21.5	81	1/4 stroke	224

*If a hole is provided to accommodate the boot when the air-hydro cylinder is mounted, make the hole diameter larger than the outside diameter of the boot mounting bracket ød.

Long Stroke (When the stroke is 1001 mm or larger)

With rod boot

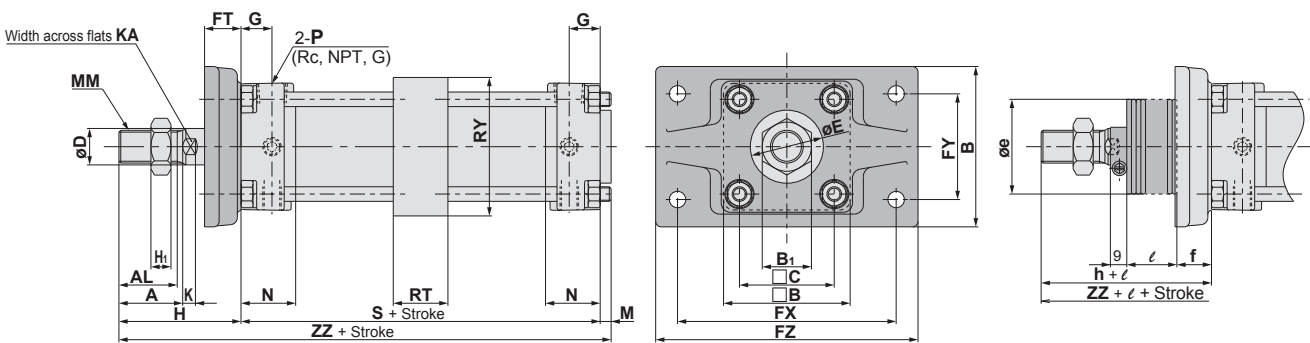

Bore size (mm)	Stroke range (mm)	A	AL	B	□B	B ₁	C	D	E	FD	FT	FX	FY	FZ	GA	GB	H ₁	J	K	KA
		50	1001 to 1200	35	32	88	70	27	52	20	40	9.0	20	120	58	144	17	17	11	M8
63	1001 to 1200	35	32	105	85	27	64	20	40	11.5	23	140	64	170	17	17	11	M10 x 1.25	7	18
80	1001 to 1400	40	37	124	102	32	78	25	52	13.5	28	164	84	198	21	21	13	M12	10	22
100	1001 to 1500	40	37	140	116	41	92	30	52	13.5	29	180	100	220	21	21	16	M12	10	26

Bore size (mm)	M	MM	N	P	RT	RY	S	Without rod boot		With rod boot					
								H	ZZ	e*	f	h	ℓ	ZZ	
50	6	M18 x 1.5	30	3/8	30	76	90	67	163	52	19	66	1/4 stroke	162	
63	10	M18 x 1.5	31	3/8	40	92	98	71	179	52	19	66	1/4 stroke	174	
80	12	M22 x 1.5	37	1/2	45	112	116	87	215	65	21	80	1/4 stroke	208	
100	12	M26 x 1.5	40	1/2	50	136	126	89	227	65	21	81	1/4 stroke	219	

*If a hole is provided to accommodate the boot when the air-hydro cylinder is mounted, make the hole diameter larger than the outside diameter of the boot mounting bracket ød.

Series CA2□H

Rear Flange/CA2GH

With rod boot

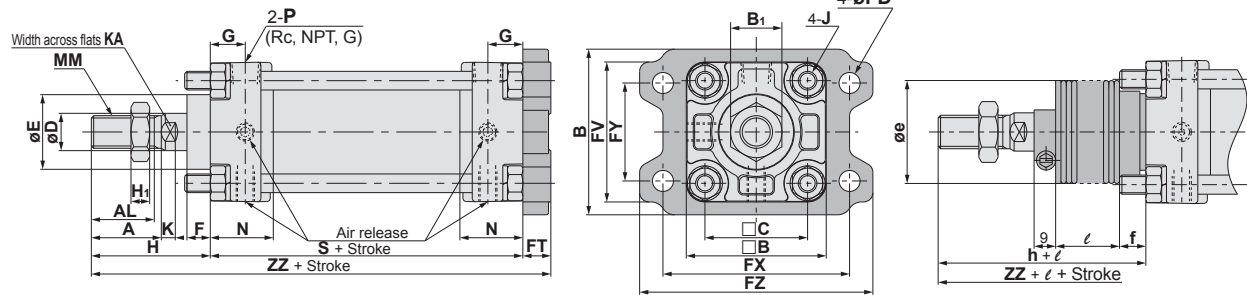

(mm)

Bore size (mm)	Stroke range (mm)		A	AL	B	□B	B ₁	C	D	E	F	FV	FD	FT	FX	FY	FZ	G	H ₁	J
	Without rod boot	With rod boot																		
40	up to 500	20 to 500	30	27	71	60	22	44	16	32	10	60	9	12	80	42	100	15	8	M8
50	up to 600	20 to 600	35	32	81	70	27	52	20	40	10	70	9	12	90	50	110	17	11	M8
63	up to 600	20 to 600	35	32	101	85	27	64	20	40	10	86	11.5	15	105	59	130	17	11	M10 x 1.25
80	up to 750	20 to 750	40	37	119	102	32	78	25	52	14	102	13.5	18	130	76	160	21	13	M12
100	up to 750	20 to 750	40	37	133	116	41	92	30	52	14	116	13.5	18	150	92	180	21	16	M12

Bore size (mm)	K	KA	MM	N	P	S	Without rod boot		With rod boot				
							H	ZZ	e	f	h	l	ZZ
40	6	14	M14 x 1.5	27	1/4	84	51	147	43	11.2	59	1/4 stroke	155
50	7	18	M18 x 1.5	30	3/8	90	58	160	52	11.2	66	1/4 stroke	168
63	7	18	M18 x 1.5	31	3/8	98	58	171	52	11.2	66	1/4 stroke	179
80	10	22	M22 x 1.5	37	1/2	116	71	205	65	12.5	80	1/4 stroke	214
100	10	26	M26 x 1.5	40	1/2	126	72	216	65	14.0	81	1/4 stroke	225

Single Clevis/CA2CH

With rod boot

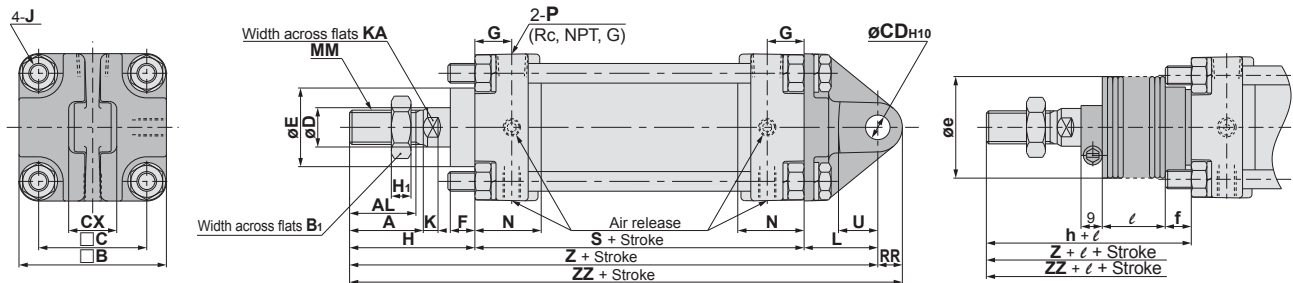

(mm)

Bore size (mm)	Stroke range (mm)		A	AL	B	B ₁	C	CD ^{H10}	CX	D	E	F	G	H ₁	J	K	KA
	Without rod boot	With rod boot															
40	up to 500	20 to 500	30	27	60	22	44	10 ₀ ^{+0.058}	15 ₀ ^{-0.1}	16	32	10	15	8	M8	6	14
50	up to 600	20 to 600	35	32	70	27	52	12 ₀ ^{+0.070}	18 ₀ ^{-0.1}	20	40	10	17	11	M8	7	18
63	up to 600	20 to 600	35	32	85	27	64	16 ₀ ^{+0.070}	25 ₀ ^{-0.1}	20	40	10	17	11	M10 x 1.25	7	18
80	up to 750	20 to 750	40	37	102	32	78	20 ₀ ^{+0.084}	31.5 ₀ ^{-0.1}	25	52	14	21	13	M12	10	22
100	up to 750	20 to 750	40	37	116	41	92	25 ₀ ^{+0.084}	35.5 ₀ ^{-0.1}	30	52	14	21	16	M12	10	26

Bore size (mm)	L	MM	N	P	RR	S	U	Z	Without rod boot		With rod boot						
									H	Z	e	f	h	l	Z	ZZ	
40	30	M14 x 1.5	27	1/4	10	84	16	165	51	165	175	43	11.2	59	1/4 stroke	173	183
50	35	M18 x 1.5	30	3/8	12	90	19	183	58	183	195	52	11.2	66	1/4 stroke	191	203
63	40	M18 x 1.5	31	3/8	16	98	23	196	58	196	212	52	11.2	66	1/4 stroke	204	220
80	48	M22 x 1.5	37	1/2	20	116	28	235	71	235	255	65	12.5	80	1/4 stroke	244	264
100	58	M26 x 1.5	40	1/2	25	126	36	256	72	256	281	65	14.0	81	1/4 stroke	265	290

Series CA2□H

Auto Switches/Proper Mounting Positions and Height for Stroke End Detection

<Band mount type>

D-B5□/B64/B59W

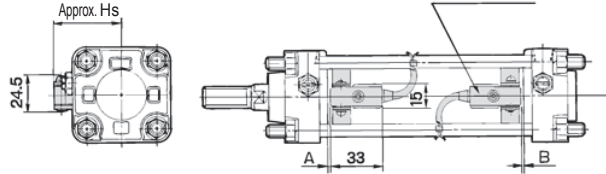

D-A3□ D-G39/K39

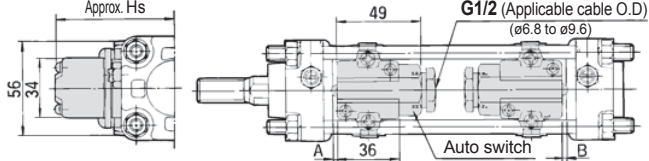

D-G5□/K59 D-G5□W/K59W D-G5BAL D-G59F/G5NTL

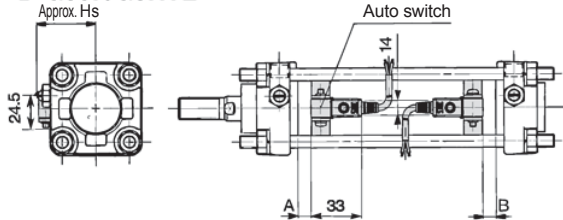

D-A44

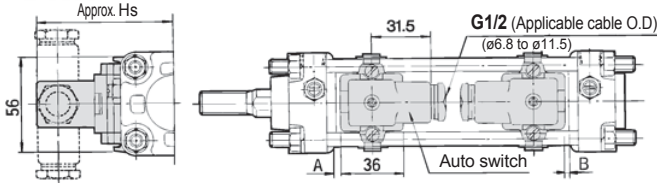

<Tie-rod mount type>

D-A5□/A6□ D-A59W

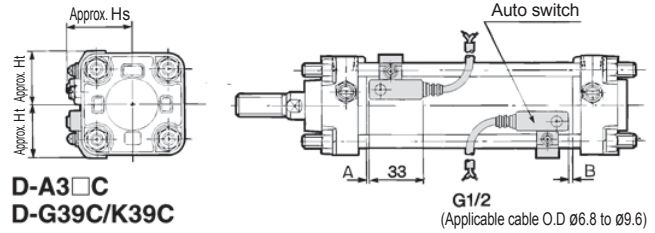

D-A3□C D-G39C/K39C

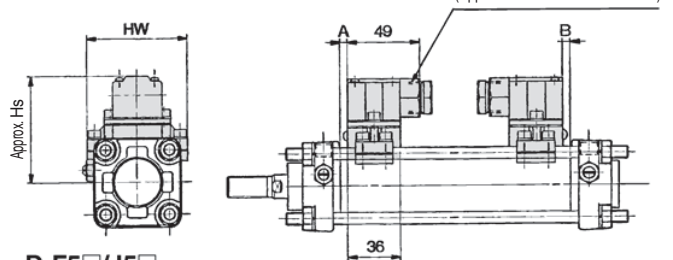

D-F5□/J5□ D-F5NTL D-F5□W/J59W D-F5BAL/F5□F

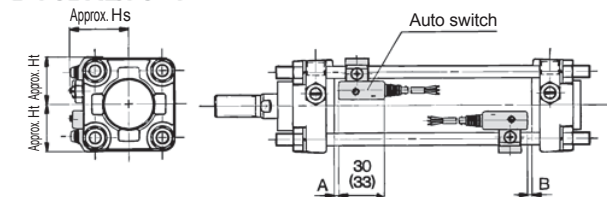

Values inside the parentheses are those for D-F5LF

D-A44C

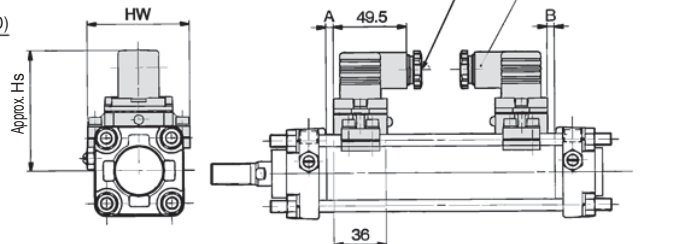

Proper Auto Switch Mounting Position

Auto switch model	D-A5□, A6□ D-A3□, A3□C D-A44, A44C D-G39, G39C D-K39, K39C		D-B5□ D-B64		D-B59W		D-F5□ D-J5□ D-F59F D-F5□W D-J59W D-F5BAL		D-G5□ D-K59 D-G5NTL D-G5□W D-K59W D-G5BAL D-G59F		D-A59W		D-F5LF		D-F5NTL	
	A	B	A	B	A	B	A	B	A	B	A	B	A	B	A	B
40	0	0	0.5	0	3.5	1.5	6.5	4.5	2	0	4	2	10.5	8.5	11.5	9.5
50	0	0	0.5	0	3.5	1.5	6.5	4.5	2	0	4	2	10.5	8.5	11.5	9.5
63	2.5	1.5	3	2	6	5	9	8	4.5	3.5	6.5	5.5	13	12	14	13
80	6	4	6.5	4.5	9.5	7.5	4.5	12.5	8	6	10	8	16.5	14.5	17.5	15.5
100	7.5	6.5	8	7	11	10	14	13	9.5	8.5	11.5	10.5	18	17	19	18

Auto Switch Mounting Height

Auto switch model	D-B5□, B64 D-B59W D-G5□ D-K59 D-G5NTL D-G5□W D-K59W D-G5BAL D-G59F		D-A3□ D-G39 D-K39		D-A44		D-A5□ D-A6□ D-A59W		D-F5□ D-J59 D-F5□W D-J59W D-F5BAL D-F5□F D-F5NTL		D-A3□C D-G39C D-K39C		D-A44C	
	Hs	Ht	Hs	Ht	Hs	Ht	Hs	Ht	Hs	Ht	Hs	Hw	Hs	Hw
38	72.5	80.5	40	31	38.5	31	73	69	81	69				
43.5	78	86	43.5	35	42.5	35	78.5	77	86.5	77				
50.5	85	93	49	42	48	42	85.5	91	93.5	91				
59	93.5	101.5	55.5	50	54	50	94	107	102	107				
69.5	104	112	63	57.5	62	57.5	104	121	112	121				

Standard type
CA2

Standard type
CA2W

Standard/Non-rotating rod
CA2K

Standard/Non-rotating rod
CA2KW

Low friction
CA2□Q

End lock
CBA2

Air-hydro
CA2□H

Air-hydro
CA2W□H

Auto switch

Made to order

Precautions

Auto Switches/Proper Mounting Positions and Height for Stroke End Detection

<Tie-rod mount type>

- D-Z7□/Z80
- D-Y59□/Y69□/Y7P/Y7PV
- D-Y7□W/Y7□WV
- D-Y7BAL

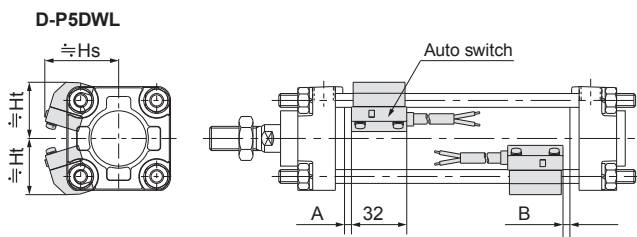
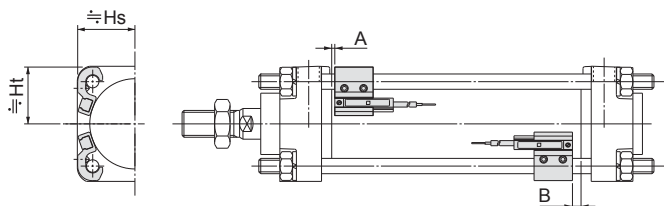

Proper Auto Switch Mounting Position (mm)

Auto switch model	D-Z7□, Z80 D-Y59□, Y69□ D-Y7P, Y7PV D-Y7□W D-Y7□WV D-Y7BAL		D-P5DWL	
	A	B	A	B
40	3.5	1.5	3	1
50	3.5	1.5	3	1
63	6	5	5.5	4
80	9.5	7.5	9	7
100	11	10	10.5	9

Auto Switch Mounting Height (mm)

Auto switch model	D-Z7□ D-Z80 D-Y59□ D-Y7P, D-Y7BAL D-Y7□W		D-Y69□ D-Y7PV D-Y7□WV		D-P5DWL	
	Hs	Ht	Hs	Ht	Hs	Ht
40	30	30	30.5	30	43	33.5
50	34	34	35	34	47	38
63	41	41	42.5	41	53	44
80	49.5	48.5	51	48.5	60	52
100	58.5	56	59	56	67	59

Operating Range

Auto switch model	Bore size (mm)				
	40	50	63	80	100
D-Z7□, Z80	8	7	9	9.5	10.5
D-A3□, A44, A3□C, A44C					
D-A5□, A6□	9	10	11	11	11
D-B5□, B64					
D-A59W	13	13	14	14	15
D-B59W	14	14	17	16	18
D-Y59□, Y69□, Y7P, Y7□V, Y7□W, Y7□WV	8	7	5.5	6.5	6.5
D-Y7BAL	3.5	3.5	5	5	5
D-F5□, J5□, F5□W, J59W, F5BAL, F5NTL	4	4	4.5	4.5	4.5
D-F59F	5.5	5	5.5	5.5	5.5
D-G5□, K59, G5□W, K59W, G5BAL, G5NTL, G59F	5	6	6.5	6.5	7
D-G39, K39, G39C, K39C	9	9	10	10	11
D-P5DWL	4	4	4.5	4	4.5

* The above operating ranges are provided as guidelines including the hysteresis and are not guaranteed values (with approx. ±30% variations). They may vary significantly with the surrounding environment.

Air-Hydro Cylinder/Double Acting Double Rod

Series CA2W□H

Air-hydro type/ø40, ø50, ø63, ø80, ø100

How to Order

Without auto switch CA2W L □ H 50 □ 100 JJ

With auto switch CDA2W L □ H 50 □ 100 JJ Y7BW □

Mounting

B	Basic
L	Axial foot
F	Front flange
T	Centre trunnion

Tube material

Nil	Aluminum tube
F*	Steel tube

* Not available with auto switch.

Hydro type

Bore size

40	40 mm
50	50 mm
63	63 mm
80	80 mm
100	100 mm

Port thread type

Nil	Rc
TN	NPT
TF	G

Cylinder stroke (mm)

Number of auto switches

Nil	2 pcs.
S	1 pc.
3	3 pcs.
n	"n" pcs.

Auto switch

Nil	Without auto switch
-----	---------------------

* Select an applicable auto switch model from the table below.
* D-Z□, Z80, Y59□, Y69□, and Y7□ are not mounted and are supplied loose. (Only the switch mounting brackets for these models are mounted.)

Cylinder suffix

Rod boot	Nil	Without rod boot
One end	J	Nylon tarpaulin
	K	Heat resistant tarpaulin
Both ends	JJ	Nylon tarpaulin
	KK	Heat resistant tarpaulin

Cylinders with built-in magnets

If built-in magnet type is ordered without auto switch, leave the field for the auto switch type blank.
(Example) CDA2WLH40-100

For more information, please refer to the next page.

Applicable Auto Switch : Refer to page 5.3 of Best Pneumatics ② for detailed auto switch specifications.

Type	Special function	Electrical entry	Indicator light	Wiring (output)	Load voltage		Auto switch model	Lead wire length (m)*			Pre-wired connector	Applicable load			
					DC	AC		0.5 (Nil)	3 (L)	5 (Z)					
Reed switch	—	Grommet	Yes	3-wire (NPN equiv.)	—	5 V	—	Z76	●	●	—	—	IC circuit	—	
	Diagnostic indication (2-colour indication)	Grommet		2-wire	24 V	12 V	100 V, 200 V	Z73	●	●	●	—	—	Relay, PLC	
								A54	●	●	●	—			
Solid state switch	—	Grommet	Yes	3-wire (NPN)	24 V	5 V, 12 V	—	Y59A	●	●	○	○	IC circuit	Relay, PLC	
				3-wire (PNP)				Y7P	●	●	○	○			
				2-wire				J51	●	●	○	—			
	Diagnostic indication (2-colour indication)	Grommet		3-wire (NPN)	24 V	12 V	5 V, 12 V	—	Y59B	●	●	○	○		—
				3-wire (PNP)					Y7NW	●	●	○	○		
				2-wire					Y7PW	●	●	○	○		
	Water resistant (2-colour indication)	Grommet		2-wire	24 V	12 V	5 V, 12 V	—	Y7BW	●	●	○	○		—
									Y7BA	—	●	○	○		
	With diagnostic output (2-colour indication)	Grommet		4-wire (NPN)	24 V	12 V	5 V, 12 V	—	F59F	●	●	○	○		IC circuit
									F5LF	●	●	○	○		—
Latch type with diagnostic output (2-colour indication)	Grommet	2-wire	24 V	12 V	5 V, 12 V	—	P5DW	—	●	●	○	—			
Magnetic field resistant (2-colour indication)	Grommet	2-wire	24 V	12 V	5 V, 12 V	—									

* Lead wire length symbol 0.5 m.....Nil (Example) A54
3 m.....L (Example) A54L
5 m.....Z (Example) A54Z

* Solid state switches marked with "○" are produced upon receipt of order.

• In addition to the models in the above table, there are some other auto switches that are applicable. For more information, refer to page 15.

Air-Hydro Cylinder/Double Acting Double Rod *Series CA2W□H*

Standard type
CA2

Standard type
CA2W

Standard/Non-rotating rod
CA2K

Standard/Non-rotating rod
CA2KW

Low friction
CA2□Q

End lock
CBA2

Air-hydro
CA2□H

Air-hydro
CA2W□H

Auto switch

Made to order

Precautions

Specifications

Type	Air-hydro type
Fluid	Turbine oil
Action	Double acting
Proof pressure	1.5 MPa
Maximum operating pressure	1.0 MPa
Minimum operating pressure	0.16 Mpa
Piston speed	0.5 to 300 mm/s
Ambient and fluid temperature	5°C to 60°C
Cushion	Without
Thread tolerance	JIS class 2
Stroke length tolerance	To 250 st : +1.0 ₋₀ , 251 to 750 st : +1.4 ₋₀
Mounting	Basic, Axial foot, Front flange, Centre trunnion

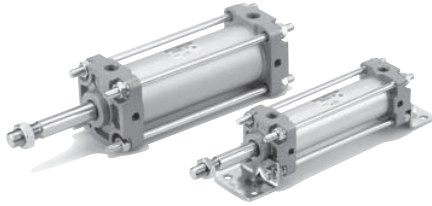

JIS symbol

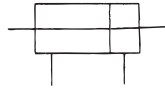

Minimum stroke for auto switch mounting

Caution

- ① The minimum stroke for mounting varies with the auto switch type and mounting type of the cylinder. In particular, the centre trunnion type needs careful attention. (For more information, please refer to page 13.)

Standard Stroke/

In case of a type with auto switch, please also refer to the table of minimum strokes for auto switch mounting on page 13.

Bore size (mm)	Standard strokes (mm)
40	25, 50, 75, 100, 125, 150, 175, 200, 250, 300, 350, 400, 450, 500
50, 63	25, 50, 75, 100, 125, 150, 175, 200, 250, 300, 350, 400, 450, 500, 600
80, 100	25, 50, 75, 100, 125, 150, 175, 200, 250, 300, 350, 400, 450, 500, 600, 700

* Intermediate strokes not listed above are produced upon receipt of order.

Rod Boot Material

Symbol	Rod boot materials	Max. ambient temperature
J	Nylon tarpaulin	70°C
K	Heat resistant tarpaulin	110°C*

* Maximum ambient temperature for the rod boot itself.

Accessory

Mounting		Basic	Foot	Flange	Centre trunnion
Standard equipment	Rod end nut	●	●	●	●
Options	Single knuckle joint	●	●	●	●
	Double knuckle joint (with pin)	●	●	●	●
	With rod boot	●	●	●	●

* The above brackets have the same dimensions as those for the standard double acting single rod Series CA2. Please refer to page 12.

Weight/Aluminum Tube (Steel tube)

Bore size (mm)		40	50	63	80	100
Basic weight	Basic	1.03 (1.08)	1.59 (1.64)	2.26 (2.30)	3.94 (4.09)	5.57 (5.78)
	Axial foot	1.22 (1.27)	1.81 (1.86)	2.59 (2.63)	4.61 (4.76)	6.65 (6.77)
	Flange	1.40 (1.45)	2.05 (2.09)	3.05 (3.09)	5.39 (5.55)	7.49 (7.70)
	Trunnion	1.39 (1.49)	2.07 (2.18)	3.06 (3.25)	5.49 (5.78)	7.85 (8.24)
Additional weight by each 50 mm stroke	All mounting brackets (except for steel tube trunnion)	0.30 (0.35)	0.40 (0.47)	0.50 (0.55)	0.71 (0.89)	0.92 (1.15)
	Steel tube trunnion	(0.44)	(0.58)	(0.77)	(1.06)	(1.35)
Accessories	Single knuckle	0.23	0.26	0.26	0.60	0.83
	Double knuckle (with pin)	0.37	0.43	0.43	0.87	1.27

Calculation example: CA2WLH40-100 (axial foot type, ø40, 100st)

- Basic weight 1.22 (axial foot, ø40)
 - Additional weight 0.30/50st
 - Cylinder stroke 100st
- 1.22 + 0.30 x 100/50 = 1.82 kg

* Values inside the parentheses are those for the steel tube type.

The minimum stroke for auto switch mounting, proper auto switch mounting position and height, operating range, applicable auto switches, auto switch mounting brackets and their part numbers, and bracket part numbers are the same as those for the double acting single rod type of Series CA2□H.

Series CA2W□H

Construction

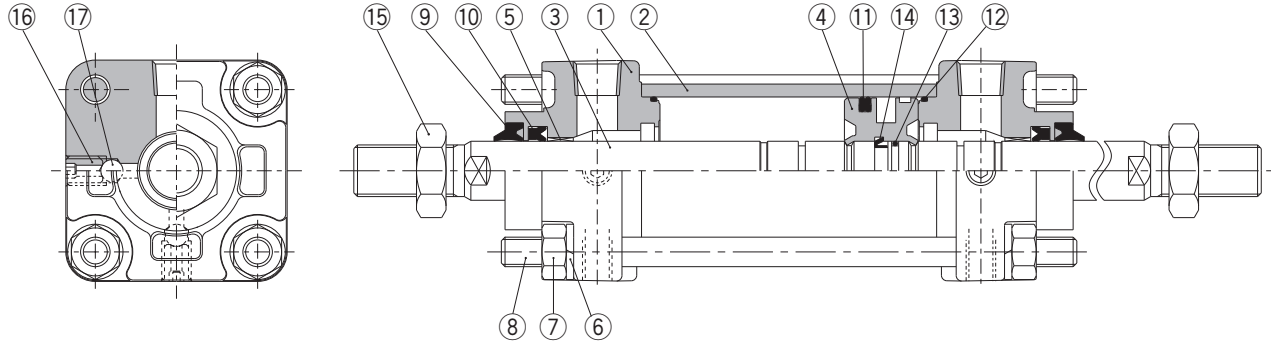

Parts List

No.	Description	Material	Note
1	Rod cover	Aluminum alloy	Metallic painted
2	Cylinder tube	Aluminum alloy	Hard anodized
3	Piston rod	Carbon steel	Hard chromium electroplated
4	Piston	Aluminum alloy	Chromated
5	Bushing	Lead-bronze casting	
6	Spring washer	Rolled steel	Chromated
7	Tie-rod nut	Rolled steel	Nickel plated
8	Tie-rod	Carbon steel	Corrosion resistant chromated
9	Scraper	NBR	
10	Rod seal	NBR	
11	Piston seal	NBR	
12	Cylinder tube gasket	NBR	
13	Piston gasket	NBR	
14	Piston holder	Urethane	
15	Rod end nut	Rolled steel	Nickel plated
16	Air release valve	Chromium molybdenum steel	Black zinc chromated
17	Check ball	Bearing steel	

Replacement Parts: Seal Kits

Bore size (mm)	Seal kit No.	Content
	Air-hydro type	
40	CA2WH40A-PS	Consists of numbers ⑩, ⑪ and ⑫ above.
50	CA2WH50A-PS	
63	CA2WH63A-PS	
80	CA2WH80A-PS	
100	CA2WH100A-PS	

Air-Hydro Cylinder/Double Acting Double Rod Series CA2W□H

Basic/CA2WBH

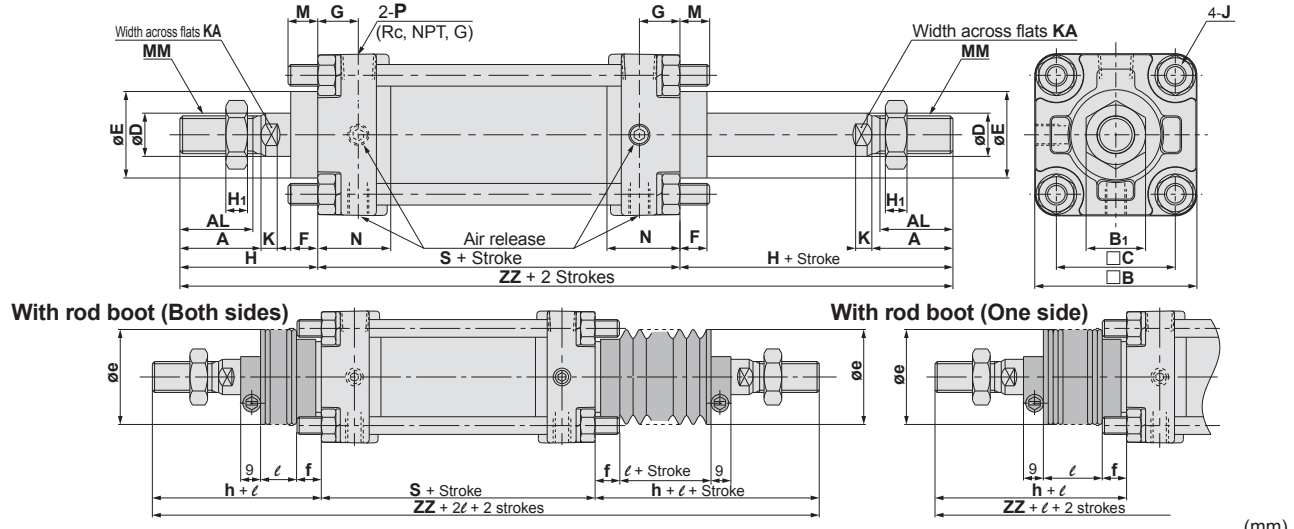

Bore size (mm)	Stroke range (mm)		A	AL	B	B ₁	C	D	E	F	G	H ₁	J	K	KA	M	MM	N
	Without rod boot	With rod boot																
40	up to 500	20 to 500	30	27	60	22	44	16	32	10	15	8	M8	6	14	11	M14 x 1.5	27
50	up to 600	20 to 600	35	32	70	27	52	20	40	10	17	11	M8	7	18	11	M18 x 1.5	30
63	up to 600	20 to 600	35	32	85	27	64	20	40	10	17	11	M10 x 1.25	7	18	14	M18 x 1.5	31
80	up to 750	20 to 750	40	37	102	32	78	25	52	14	21	13	M12	11	22	17	M22 x 1.5	37
100	up to 750	20 to 750	40	37	116	41	92	30	52	14	21	16	M12	11	26	17	M26 x 1.5	40

Bore size (mm)	P	S	Without rod boot		With rod boot (Single side)					(Both sides)	
			H	ZZ	e	f	h	l	ZZ	ZZ	
40	1/4	84	51	186	43	11.2	59	1/4 stroke	194	202	
50	3/8	90	58	206	52	11.2	66	1/4 stroke	214	222	
63	3/8	98	58	214	52	11.2	66	1/4 stroke	222	230	
80	1/2	116	71	258	65	12.5	80	1/4 stroke	267	276	
100	1/2	126	72	270	65	14.0	81	1/4 stroke	279	288	

Axial Foot/CA2WLH

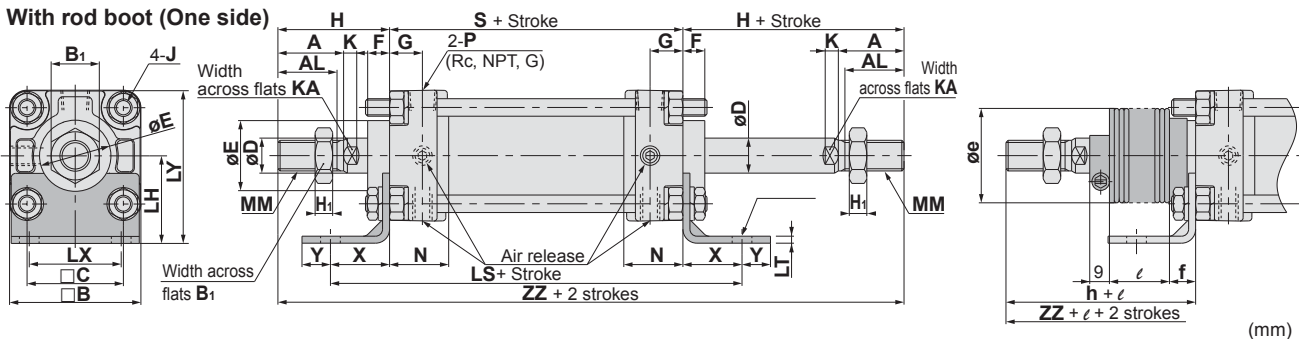

Bore size (mm)	Stroke range (mm)		A	AL	B	B ₁	C	D	E	F	G	H ₁	J	K	KA	LD	LH	LS	LT
	Without rod boot	With rod boot																	
40	up to 500	20 to 500	30	27	60	22	44	16	32	10	15	8	M8	6	14	9	40	138	3.2
50	up to 600	20 to 600	35	32	70	27	52	20	40	10	17	11	M8	7	18	9	45	144	3.2
63	up to 600	20 to 600	35	32	85	27	64	20	40	10	17	11	M10 x 1.25	7	18	11.5	50	166	3.2
80	up to 750	20 to 750	40	37	102	32	78	25	52	14	21	13	M12	11	22	13.5	65	204	4.5
100	up to 750	20 to 750	40	37	116	41	92	30	52	14	21	16	M12	11	26	13.5	75	212	6.0

Bore size (mm)	LX	LY	MM	N	P	S	W	X	Y	Without rod boot		With rod boot (Single side)					(Both sides)	
										H	ZZ	e	f	h	l	ZZ	ZZ	
40	42	70	M14 x 1.5	27	1/4	84	8	27	13	51	186	43	11.2	59	1/4 stroke	194	202	
50	50	80	M18 x 1.5	30	3/8	90	0	27	13	58	206	52	11.2	66	1/4 stroke	214	222	
63	59	93	M18 x 1.5	31	3/8	98	0	34	16	58	214	52	11.2	66	1/4 stroke	222	230	
80	76	116	M22 x 1.5	37	1/2	116	0	44	16	71	258	65	12.5	80	1/4 stroke	267	276	
100	92	133	M26 x 1.5	40	1/2	126	0	43	17	72	270	65	14.0	81	1/4 stroke	279	288	

Standard type
CA2

Standard type
CA2W

Standard/Non-rotating rod
CA2K

Standard/Non-rotating rod
CA2KW

Low friction
CA2□Q

End lock
CBA2

Air-hydro
CA2□H

Air-hydro
CA2W□H

Auto switch

Made to order

Precautions

Series CA2W□H

Front Flange/CA2WFH

With rod boot (One side)

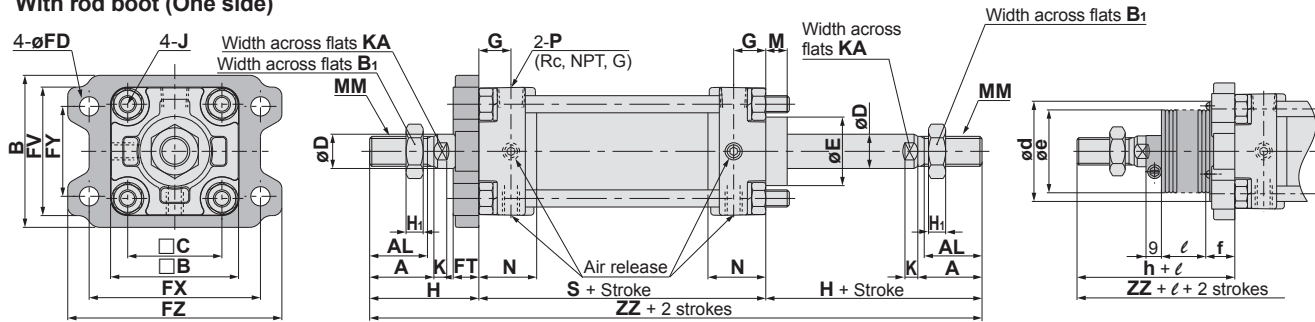

(mm)

Bore size (mm)	Stroke range (mm)		A	AL	B	□B	B ₁	C	D	E	FD	FT	FX	FY	FZ	FV	G	H ₁	J	K
	Without rod boot	With rod boot																		
40	up to 500	20 to 500	30	27	71	60	22	44	16	32	9.0	12	80	42	100	60	15	8	M8	6
50	up to 600	20 to 600	35	32	81	70	27	52	20	40	9.0	12	90	50	110	70	17	11	M8	7
63	up to 600	20 to 600	35	32	101	85	27	64	20	40	11.5	15	105	59	130	86	17	11	M10 x 1.25	7
80	up to 750	20 to 750	40	37	119	102	32	78	25	52	13.5	18	130	76	160	102	21	13	M12	11
100	up to 750	20 to 750	40	37	133	116	41	92	30	52	13.5	18	150	92	180	116	21	16	M12	11

Bore size (mm)	KA	M	MM	N	P	S	Without rod boot		With rod boot (Single side)							(Both sides)	
							H	ZZ	d*	e	f	h	l	ZZ	ZZ		
40	14	11	M14 x 1.5	27	1/4	84	51	186	52	43	15	59	1/4 stroke	194	202		
50	18	11	M18 x 1.5	30	3/8	90	58	206	58	52	15	66	1/4 stroke	214	222		
63	18	14	M18 x 1.5	31	3/8	98	58	214	58	52	17.5	66	1/4 stroke	222	230		
80	22	17	M22 x 1.5	37	1/2	116	71	258	80	65	21.5	80	1/4 stroke	267	276		
100	26	17	M26 x 1.5	40	1/2	126	72	270	80	65	21.5	81	1/4 stroke	279	288		

* If a hole is provided to accommodate the boot when the air-hydro cylinder is mounted, make the hole diameter larger than the outside diameter of the boot mounting bracket ød.

Center Trunnion/CA2WTH

With rod boot (One side)

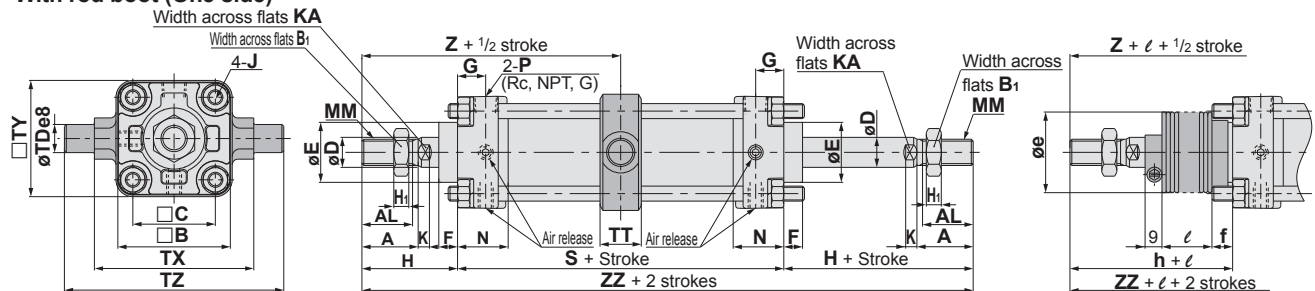

(mm)

Bore size (mm)	Stroke range (mm)		A	AL	B	B ₁	C	D	E	F	G	J	K	MM	N	P	S	TDe8
	Without rod boot	With rod boot																
40	up to 500	20 to 500	30	27	60	22	44	16	32	10	15	M8	6	M14 x 1.5	27	1/4	84	15 ^{-0.032} _{-0.059}
50	up to 600	20 to 600	35	32	70	27	52	20	40	10	17	M8	7	M18 x 1.5	30	3/8	90	15 ^{-0.032} _{-0.059}
63	up to 600	20 to 600	35	32	85	27	64	20	40	10	17	M10 x 1.25	7	M18 x 1.5	31	3/8	98	18 ^{-0.032} _{-0.059}
80	up to 750	20 to 750	40	37	102	32	78	25	52	14	21	M12	11	M22 x 1.5	37	1/2	116	25 ^{-0.040} _{-0.073}
100	up to 750	20 to 750	40	37	116	41	92	30	52	14	21	M12	11	M26 x 1.5	40	1/2	126	25 ^{-0.040} _{-0.073}

Bore size (mm)	TT	TX	TY	TZ	Without rod boot		With rod boot (Single side)							(Both sides)	
					H	Z	e	f	h	l	Z	ZZ	Z	ZZ	
40	22	85	62	117	51	93	186	43	11.2	59	1/4 stroke	101	194	101	202
50	22	95	74	127	58	103	206	52	11.2	66	1/4 stroke	111	214	111	222
63	28	110	90	148	58	107	214	52	11.2	66	1/4 stroke	115	222	115	230
80	34	140	110	192	71	129	258	65	12.5	80	1/4 stroke	138	267	138	276
100	40	162	130	214	72	135	270	65	14.0	81	1/4 stroke	144	279	144	288

Series CA2

Auto Switch Connections and Examples

Basic Wiring

Solid state 3-wire, NPN

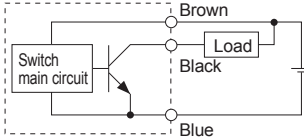

Solid state 3-wire, PNP

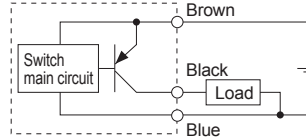

2-wire

<Solid state>

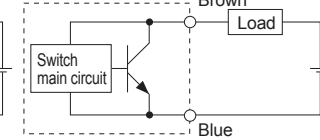

2-wire

<Reed switch>

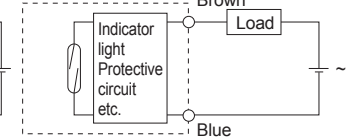

(Power supplies for switch and load are separate.)

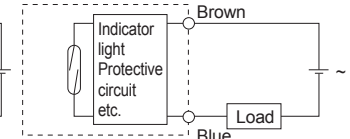
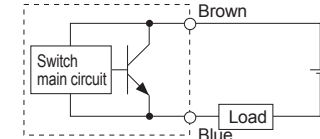
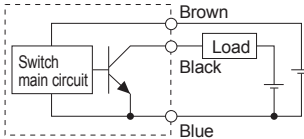

Example of Connection to PLC

• Sink input specifications 3-wire, NPN

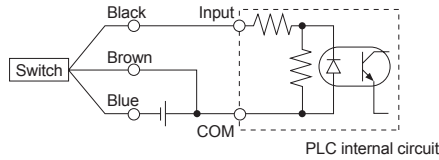

• Source input specifications 3-wire, PNP

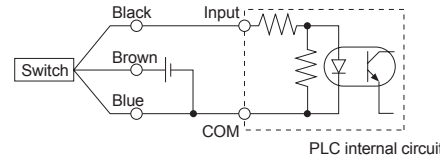

Connect according to the applicable PLC input specifications, as the connection method will vary depending on the PLC input specifications.

2-wire

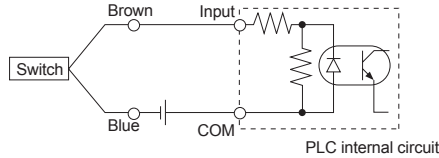

2-wire

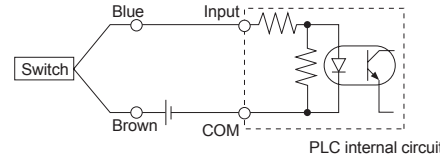

Connection Examples for AND (Series) and OR (Parallel)

• 3-wire

AND connection for NPN output (using relays)

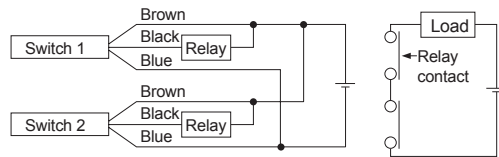

AND connection for NPN output (performed with switches only)

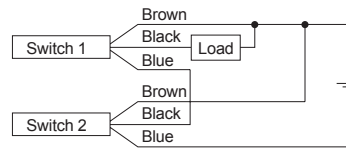

OR connection for NPN output

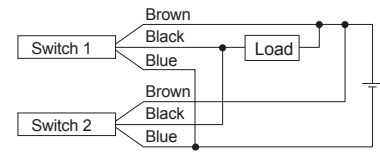

The indicator lights will light up when both switches are in the ON state.

2-wire with 2-switch AND connection

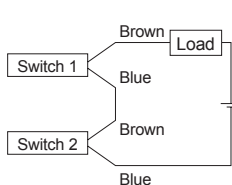

When two switches are connected in series, a load may malfunction because the load voltage will decline when in the ON state. The indicator lights will light when both switches are in the ON state.

$$\begin{aligned} \text{Load voltage at ON} &= \text{Power supply voltage} - \text{Internal voltage drop} \times 2 \text{ pcs.} \\ &= 24 \text{ V} - 4 \text{ V} \times 2 \text{ pcs.} \\ &= 16 \text{ V} \end{aligned}$$

Example: Power supply is 24 VDC.
Internal voltage drop in switch is 4 V.

2-wire with 2-switch OR connection

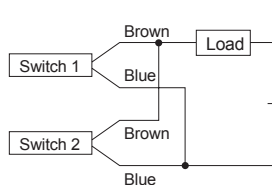

<Solid state>
When two switches are connected in parallel, malfunction may occur because the load voltage will increase when in the OFF state.

<Reed switch>
Because there is no current leakage, the load voltage will not increase when turned OFF. However, depending on the number of switches in the ON state, the indicator lights may sometimes grow dim or not light up because of the dispersion and reduction of the current flowing to the switches.

$$\begin{aligned} \text{Load voltage at OFF} &= \text{Leakage current} \times 2 \text{ pcs.} \times \text{Load impedance} \\ &= 1 \text{ mA} \times 2 \text{ pcs.} \times 3 \text{ k}\Omega \\ &= 6 \text{ V} \end{aligned}$$

Example: Load impedance is 3 kΩ.
Leakage current from switch is 1 mA.

Series CA2

Reed Switch Internal Circuits

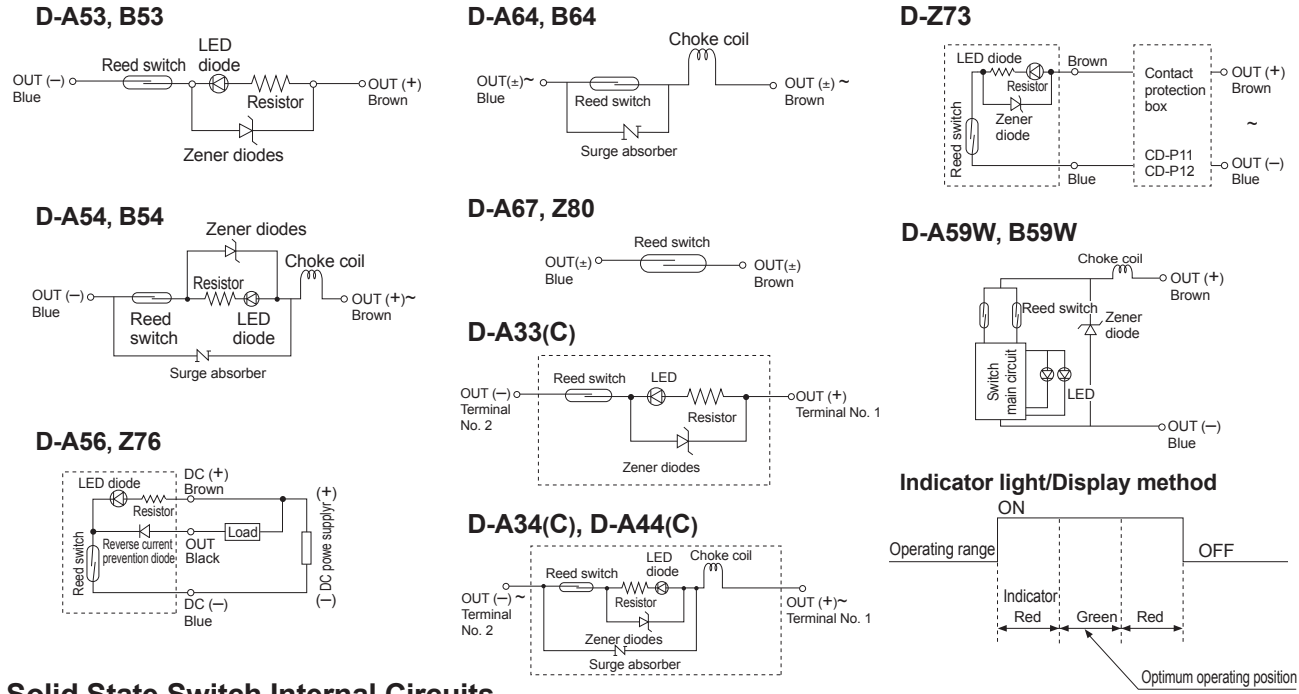

Solid State Switch Internal Circuits

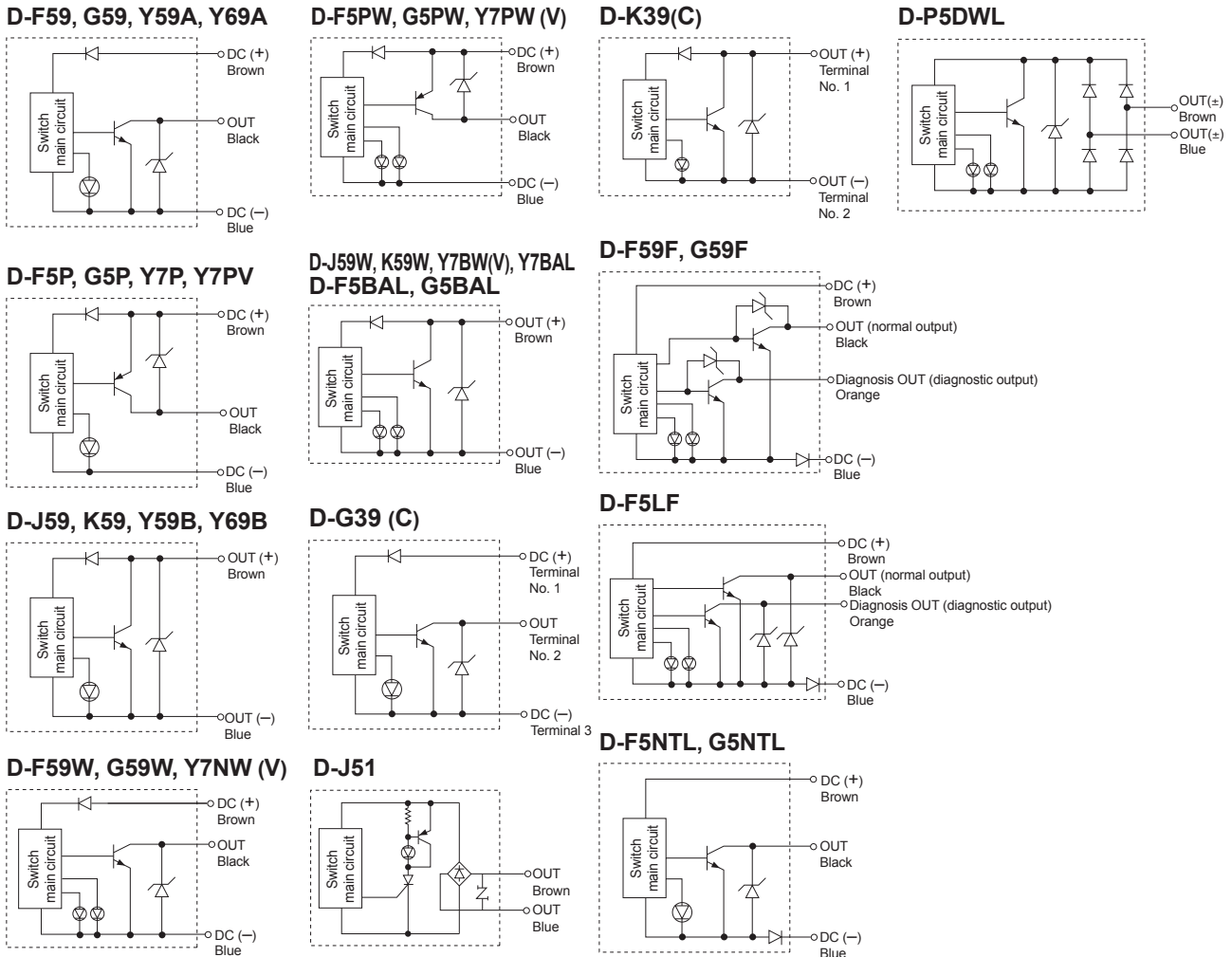

Series CA2 Simple Specials Made to Order Specifications

Contact SMC for detailed specifications, lead times and pricing.



Simple Specials Simple Special System offers the following options. Dedicated specification sheets for Simple Specials and a CD-ROM are available. Please ask your SMC sales representatives.

Symbol	Content	Single rod CA2	Double rod CA2W	Rod Non-rotating CA2K	Low friction CA2□Q	End rod CBA2	Air hydro CA2□H	Page
1 -XA0~XA30	Change of rod end shape	●	●	●	●	●	●	P. 65
2 -XC14	Change of trunnion bracket mounting position	●	●	●	●	●	●	P. 66
3 -XC15	Change of tie-rod length	●	●	●	●	●	●	P. 66

Made to Order Specifications

Symbol	Content	Single rod CA2	Double rod CA2W	Rod Non-rotating CA2K	Low friction CA2□Q	End rod CBA2	Air hydro CA2□H	Page
1 -XB5	Oversized rod	●				1*		P. 67
2 -XB6	Heat resistant (150°C)	●	●			●		
3 -XC3	Special port positions	●	●					
4 -XC4	With heavy duty scraper	●	●			1*		P. 68
5 -XC5	Heat resistant (110°C)	●	●					
6 -XC6	Piston rod and rod end nut made of stainless steel	●	●		●	1*		
7 -XC7	Tie-rod, tie-rod nut, and cushion valve made of stainless steel	●	●	●	●	●		P. 69
8 -XC8	Adjustable stroke/Extension adjustment	●		●		1*		
9 -XC9	Adjustable stroke/Retraction adjustment	●		●	●	2*		
10 -XC10	Dual stroke/Double rod	●		●				P. 70
11 -XC11	Dual stroke/Single rod	●						
12 -XC12	Tandem type	●						
13 -XC22	Fluoro rubber seal	●	●			●		P. 71
14 -XC27	Double clevis pin and double knuckle pin made of stainless steel	●	●	●	●	●		
15 -XC28	Compact flange made of SS400	●	●	●	●	●		
16 -XC29	Double knuckle joint with spring pin	●			●	●		P. 70
17 -XC30	Front trunnion	●						
18 -XC35	With coil scraper	●	●			1*		
19 -XC58	Water resistant / Built-in hard plastic magnet	●						P. 71
20 -XC59	Fluoro rubber seals and built-in hard plastic magnet	●						

Standard type
CA2

Standard type
CA2W

Standard/Non-rotating rod
CA2K

Standard/Non-rotating rod
CA2KW

Low friction
CA2□Q

End lock
CBA2

Air-hydro
CA2□H

Air-hydro
CA2W□H

Auto switch

Made to order

Precautions

Simple Specials

Change of rod end shape

1 -XA0 to XA30

Non-rotating rod end shapes are classified into the following patterns.

Series		Action	Symbol for change of rod end shape
CA2	Standard type	CA2	Double acting single rod XA0-30
		CA2W	Double acting double rod XA0-30
	Non-rotating rod	CA2K	Double acting single rod XA0, 1, 6, 10, 11, 13, 14, 17, 19, 21
	Low friction	CA2□Q	Double acting single rod XA0-30
	End Lock	CBA2	Double acting single rod XA0-30
	Air-hydro type	CA2□H	Double acting single rod XA1, 3, 5 to 8, 10, 11, 13 to 23, 26 to 30

1) SMC will make appropriate arrangements if no dimensions, tolerance, or finish instructions are given in the diagram.

2) Dimensions marked with "*" in relation to the rod diameter are found as follows. Enter any special dimension you desire.

$D \leq 6 \rightarrow D-1\text{mm}$ $6 < D \leq 25 \rightarrow D-2\text{mm}$ $D > 25 \rightarrow D-4\text{mm}$

3) In case of double rod type and single acting retraction type, enter the dimensions when the rod is retracted.

4) The options are applicable to only a single side of a double rod.

<p>Symbol: A0</p>	<p>Symbol: A1</p>	<p>Symbol: A2</p>	<p>Symbol: A3</p>
<p>Symbol: A4</p>	<p>Symbol: A5</p>	<p>Symbol: A6</p>	<p>Symbol: A7</p>
<p>Symbol: A8</p>	<p>Symbol: A9</p> <p>Approx. C0.5 file chamfer</p>	<p>Symbol: A10</p>	<p>Symbol: A11</p>
<p>Symbol: A12</p>	<p>Symbol: A13</p>	<p>Symbol: A14</p>	<p>Symbol: A15</p>
<p>Symbol: A16</p>	<p>Symbol: A17</p>	<p>Symbol: A18</p>	<p>Symbol: A19</p>
<p>Symbol: A20</p>	<p>Symbol: A21</p>	<p>Symbol: A22</p>	<p>Symbol: A23</p>
<p>Symbol: A24</p>	<p>Symbol: A25</p>	<p>Symbol: A26</p>	<p>Symbol: A27</p>
<p>Symbol: A28</p>	<p>Symbol: A29</p>	<p>Symbol: A30</p>	

2 Change of trunnion bracket mounting position -XC14

The position for mounting the trunnion bracket on the cylinder can be moved from the standard mounting position to any desired position.

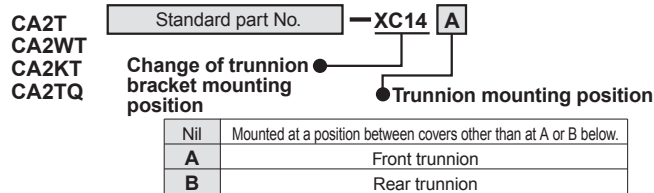

Specifications

Action	Double acting single rod
Mounting bracket	T bracket only

Other specifications are the same as those of the standard type.

Precautions

- 1) Specify "Z + 1/2 stroke" in case the trunnion bracket position is not -XC14A, B or trunnion is not a centre trunnion.
- 2) SMC will make appropriate arrangements if no dimensions, tolerance, or finish instructions are given in the diagram.
- 3) The possible range of trunnion bracket mounting position is indicated in the table below.
- 4) Some trunnion mounting positions do not allow auto switch mounting. Consult SMC for more information.

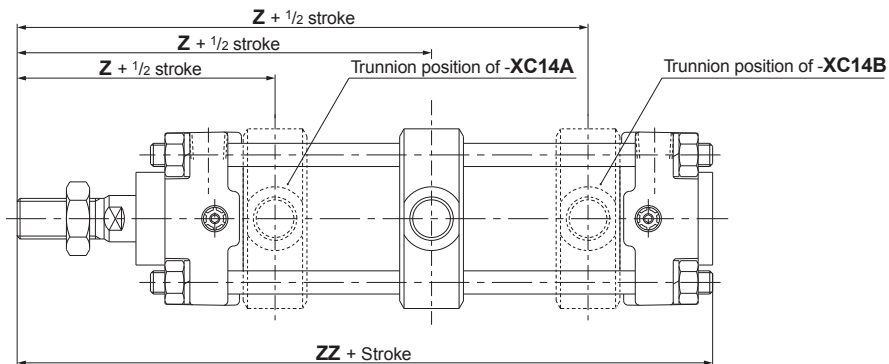

(mm)

Symbol Bore size	Z + 1/2 stroke		Z + 1/2 stroke for XC14		Reference for standard (centre trunnion)	Minimum stroke
	for XC14A	for XC14B	Minimum	Maximum		
40	89	97 + Stroke	89.5	96.5 + Stroke	93 + 1/2 stroke	0
50	99	107 + Stroke	99.5	106.5 + Stroke	103 + 1/2 stroke	0
63	103	111 + Stroke	103.5	110.5 + Stroke	107 + 1/2 stroke	0
80	125	133 + Stroke	125.5	132.5 + Stroke	129 + 1/2 stroke	0
100	132	138 + Stroke	132.5	137.5 + Stroke	135 + 1/2 stroke	0

3 Change of tie-rod length -XC15

Standard M dimension, the tie rod length of the air cylinder, is changed.

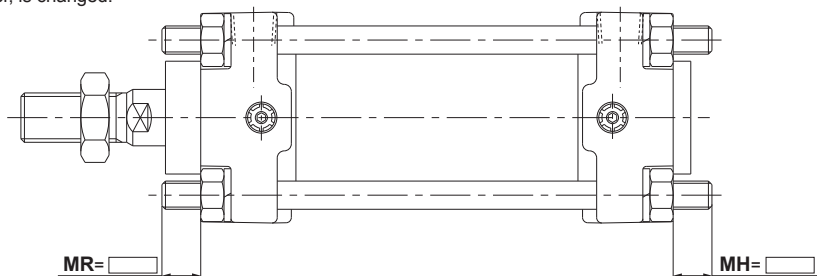
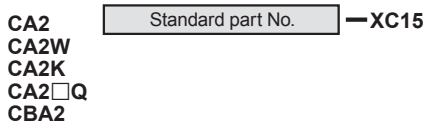

Precautions

- 1) In ordering, specify the required M dimension with the part number.
- 2) SMC will make appropriate arrangements if no dimensions, tolerance, or finish instructions are given in the diagram.
- 3) The possible range of tie-rod length is 0 to 300 mm.

Series CA2 Made to Order Specifications

1



Contact SMC for detailed dimensions, specifications, and lead times.

1 Oversized rod -XB5

The strength of the cylinder is increased by increasing the diameter of the piston rod. This cylinder is used when the stroke is long, and there is a danger of the piston rod bending or buckling, etc. (Contact SMC in case a lateral load will be applied.)

CA2 Standard part No. **-XB5**
● Heavy duty rod

Specifications

Operating direction	Double acting single rod
Bore size (mm)	40, 50, 63, 80, 100
Auto switch	Mountable

Dimensions

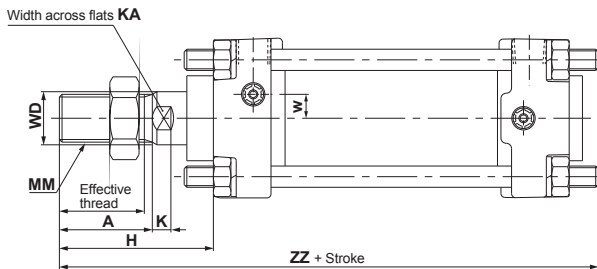

Bore size (mm)	Effective thread length	Width across flats	A	D	H	K	MM	W	ZZ
40	32	18	35	20	58	7	M18 x 1.5	9	153
50	37	22	40	25	71	11	M22 x 1.5	9	172
63	37	22	40	25	71	11	M22 x 1.5	9	183
80	37	26	40	30	72	11	M26 x 1.5	0	205
100	47	31	50	36	85	15	M30 x 1.5	0	228

2 Heat resistant (150°C) -XB6

The cylinder seals are changed to a heat resistance (to 150°C) material, for use under severe conditions which exceed the standard specifications of -10°C to +70°C.

CA2 Standard part No. **-XB6**
CA2W ● Heat resistant (150°C)

Specifications

Action	Double acting single rod/double rod
Ambient temperature range	-10 to 150°C
Auto switch	Not mountable
Cushion	Air cushion
Seal material	Fluoro rubber
Grease	Heat resistance grease

Specifications and dimensions other than the above are the same as the standard type.

3 Special port positions -XC3

The positions of ports and cushion valves on the rod cover and head cover are changed from those of the standard type.

CA2 Standard part No. **-XC3** **A** **C**
● Special port positions ● Cushion valve location viewed from rod side
Port location viewed from rod side ●

Relation of port locations and cushion valve locations

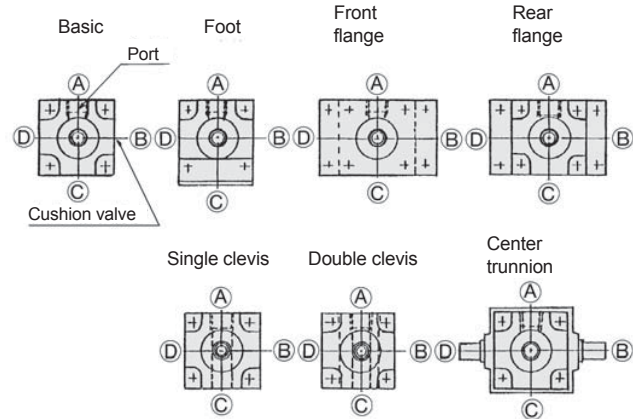

- The symbol A indicating the port or cushion valve position is assigned to the top position viewed from the rod side, with B, C, and D to the other positions in order when rotating clockwise.
- The optional combination of the port and cushion valve is available only when the same positional change is applied to the rod cover and head cover.
- The symbol -XC3 **A** **B** indicates the standard specification so an optional specification with A and B do not exist.
- Part numbers other than the symbols for the port and cushion valve positions are the same as those of the standard type.

4 With heavy duty scraper -XC4

Using a heavy duty scraper as a wiper ring, this series is ideal for use in severe environments where cylinders are exposed to dust, dirt and sand. Applicable to casting machines, construction equipment and industrial vehicles, etc.

CA2 Standard part No. **-XC4**
CA2W ● With heavy duty scraper

Specifications

Action	Double acting single rod/double rod
Cushion	Air cushion
Wiper ring	SCB scraper

Specifications and dimensions other than the above are the same as the standard type.

Construction

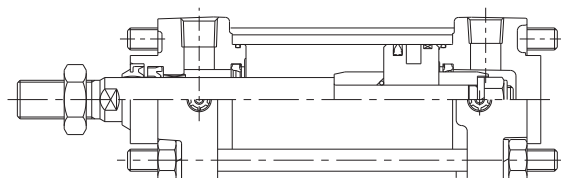

5 -XC5 Heat resistant (110°C)

The cylinder seals are changed to a heat resistant (to 110°C) material, for use under severe temperature conditions which exceed the standard specifications of -10°C to +70°C.

CA2 -XC5
 CA2W ● Heat resistant (110°C)

Specifications

Action	Double acting single rod/double rod
Ambient temperature range	-10 to 110°C
Auto switch	Not mountable
Cushion	Air cushion
Seal material	Fluoro rubber

Specifications and dimensions other than the above are the same as the standard type.

6 -XC6 Piston rod and rod end nut made of stainless steel

Applicable in cases where there is concern about rust or corrosion, etc., such as when the piston rod end gets wet when extended.

CA2 -XC6
 CA2W ● Piston rod and rod end nut made of stainless steel

Specifications

Action	Double acting single rod/double rod
Cushion	Air cushion

Specifications and dimensions other than the above are the same as the standard type.

7 -XC7 Tie-rod, tie-rod nut, and cushion valve made of stainless steel

Certain parts are changed from standard materials to stainless steel, when used in locations where there is a danger of rust or corrosion, etc

CA2 -XC7
 CA2W ● Tie-rod, tie-rod nut, and cushion valve made of stainless steel
 CA2K
 CA2Q
 CBA2

Specifications

Action	Double acting single rod/double rod
Cushion	Air cushion

Specifications and dimensions other than the above are the same as the standard type.

8 -XC8 Adjustable stroke/Extension adjustment

The extending stroke of the cylinder can be adjusted from a full stroke to (0 to 25) mm, or (0 to 50) mm. A stroke adjustment mechanism is provided on the head side to adjust the extension stroke.

CA2 - -XC8
 Stroke adjustment symbol ●
A Stroke adjustment 0 to 25 mm
B Stroke adjustment 0 to 50 mm
 Adjustable stroke /Adjustable extension ●

Specifications

Action	Double acting single rod
Mounting bracket	B, L, F, T (G, C, D not applicable)
Stroke Adjustment method	Stopper adjustment
Stroke adjustment range	A: 0 to 25 mm B: 0 to 50 mm

Other specifications are the same as those of the standard type.

Dimensions

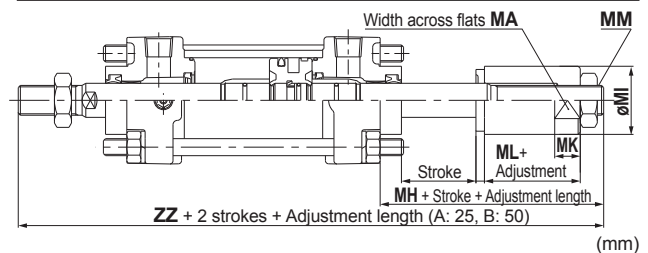

Bore size (mm)	MA	MK	MI	MH	ML	MM	ZZ
40	27	12	32	45	20	14	180
50	32	15	38	49	21	18	197
63	32	15	38	49	21	18	205
80	36	20	45	66	32	22	253
100	46	20	55	69	32	26	267

9 -XC9 Adjustable stroke/Retraction adjustment

The retracting stroke of the cylinder can be adjusted to (0 to 25) mm or (0 to 50) mm by an adjustment bolt which performs adjustable setting on the return stroke.

CA2 - -XC9
 Stroke adjustment symbol ●
A Stroke adjustment 0 to 25 mm
B Stroke adjustment 0 to 50 mm
 Adjustable stroke /Adjustable retraction ●

Specifications

Action	Double acting single rod
Mounting bracket	B, L, F, T (G, C, D not applicable)
Stroke adjustment method	Adjustment bolt
Stroke adjustment range	A: 0 to 25 mm B: 0 to 50 mm

Other specifications are the same as those of the standard type.

Dimensions

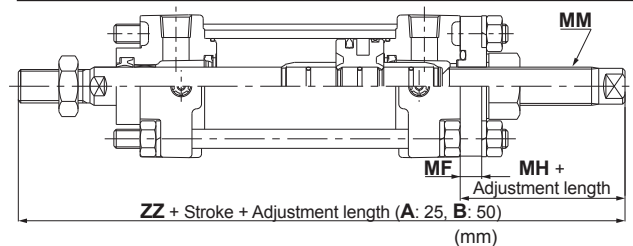

Bore size (mm)	MH	MF	MM	ZZ
40	44	9	M16 x 1.5	179
50	42	11	M16 x 1.5	190
63	48	11	M20 x 1.5	204
80	55	15	M24 x 1.5	242
100	57	15	M24 x 1.5	255

Standard type
CA2

Standard type
CA2W

Standard/Non-rotating rod
CA2K

Standard/Non-rotating rod
CA2KW

Low friction
CA2□Q

End lock
CBA2

Air-hydro
CA2□H

Air-hydro
CA2W□H

Auto switch

Made to order

Precautions

Series CA2 Made to Order Specifications

2



Contact SMC for detailed dimensions, specifications, and lead times.

10 -XC10 Dual stroke/Double rod

Two cylinders are combined in a back-to-back configuration, allowing the two reciprocating cylinder strokes to be controlled in three steps.

CA2 [Mounting] [Bore size] - [Stroke A] [Suffix] + [Stroke B] [Suffix] -XC10

Dual stroke/Double rod

Specifications

Action	Double acting single rod
Cushion	Air cushion
Mounting bracket	B, L, F, G, C, D, T (not applicable)
Maximum available stroke (A+B)	to 1000

Other specifications are the same as those of the standard type.

Dimensions

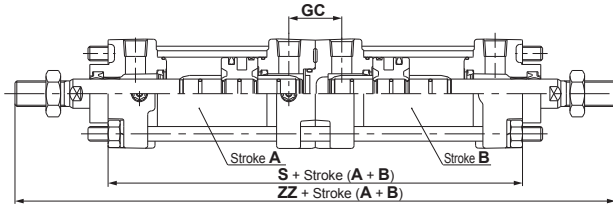

Bore size (mm)	GC	S	ZZ
40	29	167	269
50	33	179	295
63	33	195	311
80	41	231	373
100	41	251	395

12 -XC12 Tandem type

Two cylinders are connected in-line, allowing cylinder output to be doubled.

CA2 [Standard part No.] -XC12

Tandem type

Specifications

Action	Double acting single rod
Minimum operating pressure	0.1 MPa
Cushion	Air cushion
Mounting bracket	B, L, F, G, C, D (T not applicable)

Other specifications are the same as those of the standard type.

Dimensions

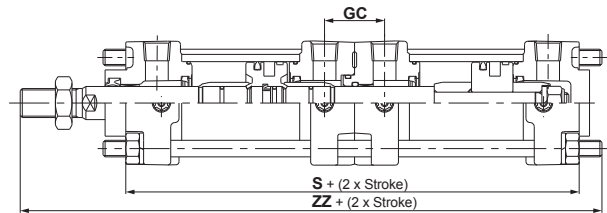

Bore size (mm)	GC	S	ZZ
40	29	169	231
50	33	181	250
63	33	197	269
80	41	233	321
100	41	253	342

11 -XC11 Dual stroke/Single rod

Two cylinders are combined in an in-line configuration, allowing the two reciprocating cylinder strokes to be controlled in two steps, or making it possible to double the cylinder output.

CA2 [Mounting] [Bore size] - [Stroke A] [Suffix] + [Stroke B-A] [Suffix] -XC11

Dual stroke/Single rod

Specifications

Action	Double acting single rod
Cushion	Air cushion
Mounting bracket	B, L, F, G, C, D (T not applicable)

Other specifications are the same as those of the standard type.

Dimensions

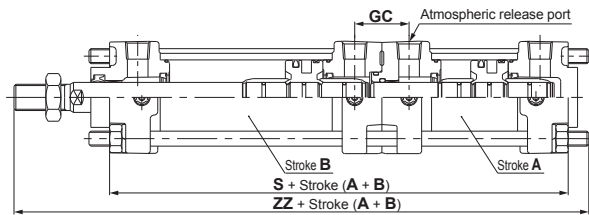

Bore size (mm)	GC	S	ZZ
40	29	168	230
50	33	180	249
63	33	196	268
80	41	232	320
100	41	252	341

13 -XC22 Fluoro rubber seal

Seals are changed to a fluoro rubber material which has outstanding resistance to chemicals.

CA2 [Standard part No.] -XC22

CA2W

Fluoro rubber seal

Specifications

Action	Double acting single rod/double rod
Seals	Fluoro rubber

Specifications and dimensions other than the above are the same as the standard type.

14-XC27 Double clevis pin and double knuckle pin made of stainless steel

To prevent the rotating part of a double clevis, which is a bracket, or double knuckle joint, which is an accessory, from rusting, the pin and the snap ring (cotter pin) are made of stainless steel.

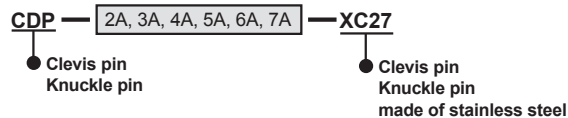
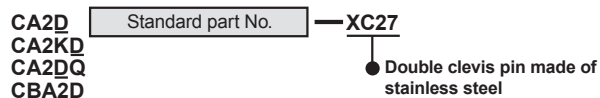

Specifications

Mounting types	Double clevis (D) only
Pin material	Stainless steel (SUS304)

Other specifications are the same as those of the standard type.
Cotter pins, clevis pins and knuckle joint pins are packed with the mounting bracket.

15-XC28 Compact flange made of SS400

Width of the front and rear flange bracket for air cylinder Series CA2 has the same dimensions as the cylinder rod cover to save the mounting space. (Flange shape and FV-dimensions are only differences from the standard type.)

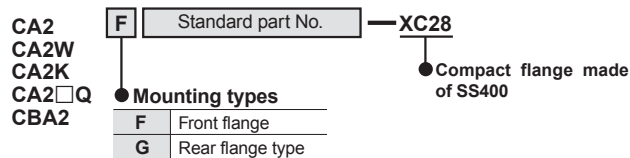

Dimensions

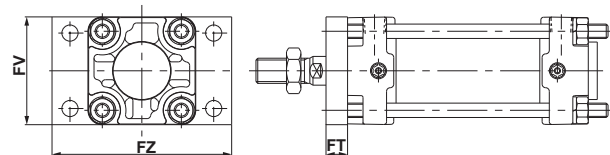

Bore size (mm)	FT	FV	FZ
40	12	60	100
50	12	70	110
63	15	85	130
80	18	102	160
100	18	116	180

* Other dimensions are the same as those of the standard front flange and rear flange. (The drawing illustrates a front flange example.)

16-XC29 Double knuckle joint with spring pin

To prevent loosening of the double knuckle joint

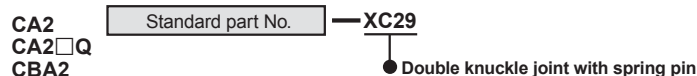

17-XC30 Front trunnion

When a standard double acting single rod cylinder supported by a front trunnion bracket has a long stroke, the trunnion bracket is mounted on the front of the cylinder's rod cover to reduce the distance from the fulcrum to the rod end.

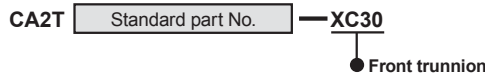

Specifications

Action	Double acting single rod/double rod
Mounting bracket	T-bracket only

Other specifications are the same as those of the standard type.

Dimensions

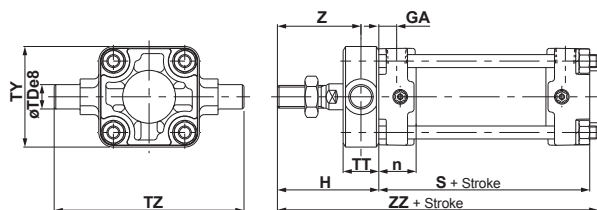

Bore size (mm)	n	ØTDe8	GA	TT	TY	TZ	H	Z	ZZ	S
40	23	15 ^{-0.032} _{-0.059}	11	22	62	117	66	55	151	80
50	26	15 ^{-0.032} _{-0.059}	13	22	74	127	71	60	163	86
63	27	18 ^{-0.032} _{-0.056}	13	28	90	148	79	65	179	94
80	32	25 ^{-0.040} _{-0.073}	16	34	110	192	94.5	77.5	212.5	111
100	35	25 ^{-0.040} _{-0.073}	16	40	130	214	100	80	229	121

18-XC35 With coil scraper

Seals are protected by removing frost, welding spatter or cutting chips, etc. that adhere to the piston rod.

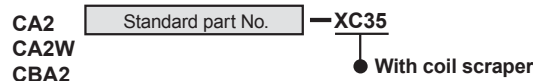

Specifications

Action	Double acting single rod/double rod
Cushion	Air cushion
Wiper ring	Coil scraper (metal)

Specifications and dimensions other than the above are the same as the standard type.

Construction

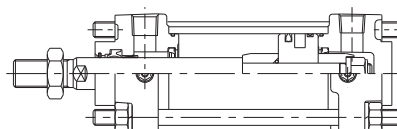

Standard type CA2
Standard type CA2W
Standard/Non-rotating rod CA2K
Standard/Non-rotating rod CA2KW
Low friction CA2□Q
End lock CBA2
Air-hydro CA2□H
Air-hydro CA2W□H
Auto switch
Made to order
Precautions

Series CA2 Made to Order Specifications

Contact SMC for detailed dimensions, specifications, and lead times.

3



Water resistant/Built-in hard plastic magnet

19-XC58

The magnet for auto switch on a water resistant cylinder is made of hard plastic in order to prevent swelling.

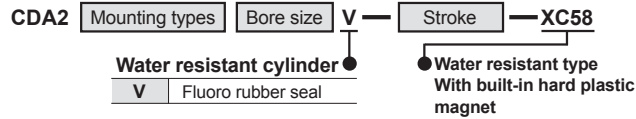

Fluoro rubber seals and built-in hard plastic magnet

20-XC59

The magnet for auto switch on a fluoro rubber seal cylinder is made of hard plastic in order to prevent swelling.

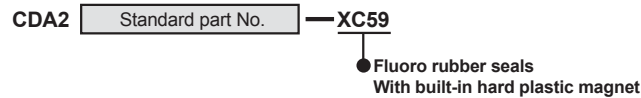

⚠ Caution

- ① Confirm with SMC, as the type of chemical and the operating temperature may not allow the use of this product.
- ② Although the cylinder is available with auto switch, confirm its compatibility with the operating environment with SMC before it is put to use. This is because it uses the same auto switch related parts (auto switch body and mounting bracket) as the standard type.



Series CA2 Safety Instructions

These safety instructions are intended to prevent a hazardous situation and/or equipment damage. These instructions indicate the level of potential hazard by a label of “**Caution**”, “**Warning**” or “**Danger**”. To ensure safety, be sure to observe ISO 4414 ^{Note 1)}, JIS B 8370 ^{Note 2)} and other safety practices.

⚠ Caution: Operator error could result in injury or equipment damage.

⚠ Warning: Operator error could result in serious injury or loss of life.

⚠ Danger: In extreme conditions, there is a possible result of serious injury or loss of life.

Note 1) ISO 4414: Pneumatic fluid power – General Rules relating to systems and control systems.

Note 2) JIS B 8370: Pneumatic system axiom

⚠ Warning

- 1. The compatibility of pneumatic equipment is the responsibility of the person who designs the pneumatic system or decides its specifications.**
 Since the products specified here are used in various operating conditions, their compatibility for the specific pneumatic system must be based on specifications or after analysis and/or tests to meet your specific requirements. The expected performance and safety assurance will be the responsibility of the person who has determined the compatibility of the system. This person should continuously review the suitability of all items specified, referring to the latest catalogue information with a view to giving due consideration to any possibility of equipment failure when configuring a system.
- 2. Only trained personnel should operate pneumatically operated machinery and equipment.**
 Compressed air can be dangerous if handled incorrectly. Assembly, handling or repair of pneumatic systems should be performed by trained and experienced operators.
- 3. Do not service machinery/equipment or attempt to remove components until safety is confirmed.**
 1. Inspection and maintenance of machinery/equipment should only be performed after confirmation of safe locked-out control positions.
 2. When equipment is to be removed, confirm the safety process as mentioned above. Cut the supply pressure for this equipment and exhaust all residual compressed air in the system.
 3. Before machinery/equipment is restarted, take measures to prevent shooting-out of cylinder piston rod, etc.
- 4. Contact SMC if the product is to be used in any of the following conditions:**
 1. Conditions and environments beyond the given specifications, or if product is used outdoors.
 2. Installation on equipment in conjunction with atomic energy, railway, air navigation, vehicles, medical equipment, food and beverages, recreation equipment, emergency stop circuits, clutch and brake circuits in press applications, or safety equipment.
 3. An application which has the possibility of having negative effects on people, property, or animals, requiring special safety analysis.

Standard type CA2
Standard type CA2W
Standard/Non-rotating rod CA2K
Standard/Non-rotating rod CA2KW
Low friction CA2□□
End lock CBA2
Air-hydro CA2□□H
Air-hydro CA2W□□H
Auto switch
Made to order
Precautions



Series CA2 Actuator Precautions ①

Be sure to read before handling.

Design

⚠ Warning

1. There is a possibility of dangerous sudden action by air cylinders if sliding parts of machinery are twisted due to external forces, etc.

In such cases, human injury may occur; e.g., by catching hands or feet in the machinery, or damage to the machinery itself may occur. Therefore, the machine should be adjusted to operate smoothly and designed to avoid such dangers.

2. A protective cover is recommended to minimize the risk of personal injury.

If a stationary object and moving parts of a cylinder are in close proximity, personal injury may occur. Design the structure to avoid contact with the human body.

3. Securely tighten all stationary parts and connected parts so that they will not become loose.

Especially when a cylinder operates with high frequency or is installed where there is a lot of vibration, ensure that all parts remain secure.

4. A deceleration circuit or shock absorber may be required.

When a driven object is operated at high speed or the load is heavy, a cylinder's cushion will not be sufficient to absorb the impact. Install a deceleration circuit to reduce the speed before cushioning, or install an external shock absorber to relieve the impact.

In this case, the rigidity of the machinery should also be examined.

5. Consider a possible drop in circuit pressure due to a power outage, etc.

When a cylinder is used in a clamping mechanism, there is a danger of work pieces dropping if there is a decrease in clamping force due to a drop in circuit pressure caused by a power outage, etc. Therefore, safety equipment should be installed to prevent damage to machinery and human injury. Suspension mechanisms and lifting devices also require consideration for drop prevention.

6. Consider a possible loss of power source.

Measures should be taken to protect against bodily injury and equipment damage in the event that there is a loss of power to equipment controlled by pneumatics, electricity, or hydraulics.

7. Design a circuit that will prevent the driven object from shooting out.

The driven object will shoot out at a high speed if one side of the cylinder is pressurised after the air inside the cylinder is exhausted; for example, when the cylinder is driven with exhaust center directional control valves or when it is started after the residual pressure inside the circuit is exhausted.

Such an event can possibly lead to bodily injury, by, for example, catching in human limbs, or damage to the machinery. Therefore, select equipment and design circuits to prevent shoot-outs.

8. Consider emergency stops.

Design so that human injury and/or damage to machinery and equipment will not be caused when machinery is stopped by a safety device under abnormal conditions, a power outage or a manual emergency stop.

9. Consider the action when operation is restarted after an emergency stop or abnormal stop.

Design the machinery so that human injury or equipment damage will not occur upon restart of operation.

When the cylinder has to be reset at the starting position, install manual safety equipment.

Selection

⚠ Warning

1. Check the specifications.

The products featured in this catalogue are designed for use in industrial compressed air systems. If the products are used in conditions where pressure and/or temperature are outside the range of specifications, damage and/or malfunctions may occur. Do not use in these conditions. (Refer to specifications.)

Consult with SMC if you use a fluid other than compressed air.

2. Intermediate stops

When intermediate stopping of a cylinder piston is performed with a 3-position closed centre type directional control valve, it is difficult to achieve stopping positions as accurately and precisely as with hydraulic pressure due to the compressibility of air.

Furthermore, since valves and cylinders are not guaranteed for zero air leakage, it may not be possible to hold a stopped position for an extended period of time. Contact SMC in case it is necessary to hold a stopped position for an extended period.

⚠ Caution

1. Operate within the limits of the maximum usable stroke.

The piston rod will be damaged if operated beyond the maximum stroke. Refer to the cylinder model selection procedures for the maximum usable stroke.

2. Operate the piston within a range such that collision damage will not occur at the stroke end.

The operation range should prevent damage from occurring when a piston, having inertial force, stops by striking the cover at the stroke end. Refer to the cylinder model selection procedure for the maximum usable stroke.

3. Use a speed controller to adjust the cylinder drive speed, gradually increasing from a low speed to the desired speed setting.

4. Provide intermediate supports for long stroke cylinders.

An intermediate support should be provided in order to prevent damage to a cylinder having a long stroke, due to problems such as sagging of the rod deflection of the cylinder tube, vibration and external load.



Series CA2 Actuator Precautions ②

Be sure to read before handling.

Mounting

⚠ Caution

1. Be certain to match the rod shaft centre with the load and direction of movement when connecting.

When not properly matched, problems may arise with the rod and tube, and damage may be caused due to friction on areas such as the inner tube surface, bushings, rod surface, and seals.

2. When an external guide is used, connect the rod end and the load in such a way that there is no interference at any point within the stroke.

3. Do not scratch or gouge the sliding parts of the cylinder tube or piston rod by striking or grasping them with other objects.

Cylinder bores are manufactured to precise tolerances, so that even a slight deformation may cause faulty operation.

Moreover, scratches or gouges, etc. in the piston rod may lead to damaged seals and cause air leakage.

4. Prevent the seizure of rotating parts.

Prevent the seizure of rotating parts (pins, etc.) by applying grease.

5. Do not use until you verify that the equipment can operate properly.

After mounting, repairs, or modification, etc., connect the air supply and electric power, and then confirm proper mounting by means of appropriate function and leak tests.

6. Instruction manual

The product should be mounted and operated after the instruction manual is thoroughly read and its contents are understood.

Keep the instruction manual where it can be referred to as needed.

Piping

⚠ Caution

1. Preparation before piping

Before piping is connected, it should be thoroughly blown out with air (flushing) or washed to remove chips, cutting oil and other debris from inside the pipe.

2. Wrapping of sealant tape

When screwing together pipes and fittings, be certain that chips from the pipe threads and sealing material do not get inside the piping.

Also, when sealant tape is used, leave 1.5 to 2 thread ridges exposed at the end of the pipe.

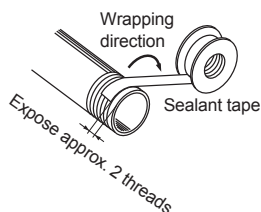

Cushion

⚠ Caution

1. Readjust using the cushion needle.

Cushions are adjusted at the time of shipment, however, the cushion needle on the cover should be readjusted when the product is put into service, based upon factors such as the size of the load and the operating speed. When the cushion needle is turned clockwise, the restriction becomes smaller and the cushion's effectiveness is increased. Tighten the lock nut securely after adjustment is performed.

2. Do not use the cushion needle fully closed.

It can cause damage to seals.

Lubrication

⚠ Caution

1. Lubrication of non-lube type cylinder.

The cylinder is lubricated for life at the factory and can be used without any further lubrication.

However, in the event that it is lubricated additionally, be sure to use class 1 turbine oil (with no additives) ISO VG32.

Stopping lubrication later may lead to malfunctions because the new lubricant will cancel out the original lubricant. Therefore, lubrication must be continued once it has been started.

Air Supply

⚠ Warning

1. Use clean air.

Do not use compressed air that includes chemicals, synthetic oils containing organic solvents, salt or corrosive gases, etc., as it can cause damage or malfunction.

⚠ Caution

1. Install air filters.

Install air filters at the upstream side of valves. The filtration degree should be 5 μm or finer.

2. Install an after-cooler, air dryer, or water separator (Drain Catch).

Air that includes much drainage can cause malfunction of valves and other pneumatic equipment. To prevent this, install an after-cooler, air dryer or water separator, etc.

3. Use the product within the specified range of fluid and ambient temperature.

Take measures to prevent freezing when below 5°C, since moisture in circuits can freeze and cause damage to seals and lead to malfunctions.

Refer to SMC's Best Pneumatics catalogue Vol.4 for further details on compressed air quality.

Standard type
CA2

Standard type
CA2W

Standard/Non-rotating rod
CA2K

Standard/Non-rotating rod
CA2KW

Low friction
CA2□Q

End lock
CBA2

Air-hydro
CA2□H

Air-hydro
CA2W□H

Auto switch

Made to order

Precautions



Series CA2 Actuator Precautions ③

Be sure to read before handling.

Operating Environment

Warning

1. Do not use in environments where there is a danger of corrosion.

Refer to the construction drawings regarding cylinder materials.

2. In dusty locations or where water or oil, etc., splash on the equipment, take suitable measures to protect the rod.

Use the heavy duty scraper type (-XC4) in situations where there is a lot of dust. Use a water resistant cylinder when there is splash or spray of liquids.

Maintenance

Warning

1. Perform maintenance inspection and service according to the procedures indicated in the instruction manual.

If handled improperly, malfunction and damage of machinery or equipment may occur.

2. Removal of components, and supply/exhaust of compressed air

Before any machinery or equipment is removed, first ensure that the appropriate measures are in place to prevent the fall or erratic movement of driven objects and equipment, then cut off the electric power and reduce the pressure in the system to zero. Only then should you proceed with the removal of any machinery and equipment.

When machinery is restarted, proceed with caution after confirming that appropriate measures are in place to prevent cylinders from sudden movement.

Caution

1. Drain flushing

Remove drainage from air filters regularly.



Series CA2 Auto Switch Precautions ①

Be sure to read before handling.

Design and Selection

⚠ Warning

1. Check the specifications.

Read the specifications carefully and use this product appropriately. The product may be damaged or malfunction if it is used outside the range of specifications of load current, voltage, temperature or impact.

2. Take precautions when multiple cylinders are used close together.

When two or more auto switch cylinders are lined up in close proximity to each other, magnetic field interference may cause the switches to malfunction. Maintain a minimum cylinder separation of 40 mm. (When the allowable interval is specified for each cylinder series, use the indicated value.)

3. Pay attention to the length of time that a switch is ON at an intermediate stroke position.

When an auto switch is placed at an intermediate position of the stroke and a load is driven at the time the piston passes, the auto switch will operate, but if the speed is too great, the operating time will be shortened and the load may not operate properly. The maximum detectable piston speed is:

$$V \text{ (mm/s)} = \frac{\text{Auto switch operating range (mm)}}{\text{Load operating time (ms)}} \times 1000$$

If the piston moves too fast, the operation time of the load can be extended by the use of an auto switch with off-delay timer (approx. 200 ms) (D-F5NT).

4. Keep wiring as short as possible.

<Reed switches>

As the length of the wiring to a load gets longer, the rush current at switching ON becomes greater, and this may shorten the product's life. (The switch will stay ON all the time.)

- 1) For an auto switch without a contact protection circuit, use a contact protection box when the wire length is 5 m or longer.
- 2) Even when an auto switch has a built-in contact protection circuit, if the lead wire length is 30 m or more, the rush current cannot be adequately absorbed and the life of the switch may be shortened. Contact SMC, as it is also necessary in this case to connect a contact protection box to extend the switch life.

<Solid state switches>

- 3) Although wire length should not affect switch function, use a wire that is 100 m or shorter.

5. Take precautions for the internal voltage drop of the switch.

<Reed switches>

1) Switches with an indicator light (except D-Z76, A56)

• If auto switches are connected in series as shown below, take note that there will be a large voltage drop because of internal resistance in the light emitting diodes. (Refer to internal voltage drop in the auto switch specifications.)

[The voltage drop will be "n" times larger when "n" auto switches are connected.]

Even though an auto switch operates normally, the load may not operate.

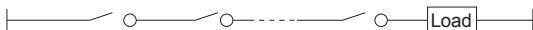

- Similarly, when operating below a specified voltage, it is possible that the load may be ineffective even though the auto switch function is normal. Therefore, the formula below should be satisfied after confirming the minimum operating voltage of the load.

$$\text{Supply voltage} - \text{Internal voltage drop of switch} > \text{Minimum operating voltage of load}$$

- 2) If the internal resistance of a light emitting diode causes a problem, select a switch without an indicator light (models D-Z80, A6□).

<Solid state switches>

- 3) Generally, the internal voltage drop will be greater with a 2-wire solid state auto switch than with a reed switch. Take the same precautions as in 1) above.

Also note that a 12VDC relay is not applicable.

6. Pay attention to leakage current.

<Solid state switches>

With a 2 wire solid state auto switch, current (leakage current) flows to the load to operate the internal circuit even when in the OFF state.

$$\text{Current to operate load (OFF condition)} > \text{Leakage current}$$

If the condition given in the above formula is not met, it will not reset correctly (stays on). Use a 3-wire switch if this specification cannot be satisfied.

Moreover, leakage current flow to the load will be "n" times larger when "n" auto switches are connected in parallel.

7. Do not use a load that generates surge voltage.

<Reed switches>

If driving a load such as a relay that generates a surge voltage, use a switch with a built-in contact protection circuit or use a contact protection box.

<Solid state switches>

Although a zener diode for surge protection is connected at the output side of a solid state auto switch, damage may still occur if the surge is applied repeatedly. When a load, such as a relay or solenoid, which generates surge is directly driven, use a type of switch with a built-in surge absorbing element.

8. Cautions for use in an interlock circuit

When an auto switch is used for an interlock signal requiring high reliability, devise a double interlock system to avoid trouble by providing a mechanical protection function, or by also using another switch (sensor) together with the auto switch.

Also perform periodic maintenance inspections and confirm proper operation.

9. Ensure sufficient clearance for maintenance activities.

When designing an application, be sure to allow sufficient clearance for maintenance and inspections.

Standard type
CA2

Standard type
CA2W

Standard/Non-rotating rod
CA2K

Standard/Non-rotating rod
CA2KW

Low friction
CA2□Q

End lock
CBA2

Air-hydro
CA2□H

Air-hydro
CA2W□H

Auto switch

Made to order

Precautions



Series CA2 Auto Switch Precautions ②

Be sure to read before handling.

Mounting and Adjustment

⚠ Warning

1. Do not drop or bump.

Do not drop, bump, or apply excessive impacts (300 m/s² or more for reed switches and 1000 m/s² or more for solid state switches) while handling. Although the body of the switch may not be damaged, the inside of the switch could be damaged and cause a malfunction.

2. Do not carry a cylinder by the auto switch lead wires.

Never carry a cylinder by its lead wires. This may not only cause broken lead wires, but it may cause internal elements of the switch to be damaged by the stress.

3. Mount switches using the proper tightening torque.

When a switch is tightened beyond the torque range, the mounting screws, mounting bracket or switch may be damaged.

On the other hand, tightening below the torque range may allow the switch to slip out of position. (Refer to page 5.3-69 of Best Pneumatics Vol.2 for switch mounting, movement and tightening torque.)

4. Mount a switch at the center of the operating range.

Adjust the mounting position of an auto switch so that the piston stops at the center of the operating range (the range in which a switch is ON). (The mounting position shown in a catalogue indicates the optimum position at stroke end.) If mounted at the end of the operating range (around the borderline of ON and OFF), operation will be unstable.

Wiring

⚠ Warning

1. Avoid repeatedly bending or stretching lead wires.

Broken lead wires will result from repeatedly applying bending stress or stretching force to the lead wires.

2. Be sure to connect the load before power is applied.

<2-wire type>

If the power is turned on when an auto switch is not connected to a load, the switch will be instantly damaged because of excess current.

3. Confirm proper insulation of wiring.

Be certain that there is no faulty wiring insulation (contact with other circuits, ground fault, improper insulation between terminals, etc.). Damage may occur due to excess current flow into a switch.

4. Do not wire with power lines or high voltage lines.

Wire separately from power lines or high voltage lines, avoiding parallel wiring or wiring in the same conduit with these lines. Control circuits including auto switches may malfunction due to noise from these other lines.

Wiring

5. Do not allow short circuiting of loads.

<Read switches>

If the power is turned on with a load in a short circuited condition, the switch will be instantly damaged because of excess current flow into the switch.

<Solid state switches>

J51 type and all models of PNP output type switches do not have built-in short circuit protection circuits. If loads are short circuited, the switches will be instantly damaged, as in the case of reed switches.

Take special care to avoid reverse wiring with the brown [red] power supply line and the black [white] output line on 3-wire type switches.

6. Avoid incorrect wiring.

<Reed switches>

A 24 VDC switch with indicator light has polarity. The brown [red] lead wire or terminal No. 1 is (+), and the blue [black] lead wire or terminal No. 2 is (-).

- 1) If connections are reversed, the switch will still operate, but the light emitting diode will not light up.
Also note that a current greater than the maximum specified one will damage a light emitting diode and make it inoperable.
- 2) Note, however, in case of 2-colour indication type auto switch (D-A59W, B59W), if the wiring is reversed, the switch will remain in a normally on condition.

<Solid state switches>

- 1) Even if connections are reversed on a 2-wire type switch, the switch will not be damaged because it is protected by a protection circuit, but it will remain in a normally ON state. However, it is still necessary to avoid reversed connections since the switch will be damaged if a load short circuits in this condition.
- 2) Even if (+) and (-) power supply line connections are reversed on a 3-wire type switch, the switch will still be protected by a protection circuit. However, if the (+) power supply line is connected to the blue [black] wire and the (-) power supply line is connected to the black [white] wire, the switch will be damaged.

* Lead wire colour changes

Lead wire colours of SMC switches have been changed in order to meet NECA Standard 0402 for production beginning September, 1996 and thereafter. Please refer to the tables provided. Special care should be taken regarding wire polarity during the time that the old colours still coexist with the new colours.

2-wire

	Old	New
Output (+)	Red	Brown
Output (-)	Black	Blue

3-wire

	Old	New
Power supply (+)	Red	Brown
Power supply GND	Black	Blue
Output	White	Black

Solid state with diagnostic output

	Old	New
Power supply (+)	Red	Brown
Power supply GND	Black	Blue
Output	White	Black
Diagnostic output	Yellow	Orange

Solid state with latch type diagnostic output

	Old	New
Power supply (+)	Red	Brown
Power supply GND	Black	Blue
Output	White	Black
Latch type diagnostic output	Yellow	Orange



Series CA2 Auto Switch Precautions ③

Be sure to read before handling.

Operating Environment

⚠ Warning

- Never use in the presence of explosive gases.**
The construction of our auto switches does not make them explosion-proof. Never use them in the presence of an explosive gas, as this may cause a serious explosion.
- Do not use in an area where a magnetic field is generated.**
Auto switches will malfunction or magnets inside cylinders will become demagnetized. (Consult with SMC regarding the availability of a magnetic field resistant auto switch.)
- Do not use in an environment where the auto switch will be continually exposed to water.**
Switches are conformed to IEC Standards IP67 construction (JISC0920: Watertight construction) except for several models (D-A3□(C), A44(C), G39(C), K39(C)).
Nevertheless, they should not be used in applications where they are continuously exposed to water splash or spray. Malfunction may occur due to false insulation or swelling of potting resin inside the switch.
- Do not use in an environment with oil or chemicals.**
Consult with SMC if auto switches will be used in an environment with coolants, cleaning solvents, various oils or chemicals. If auto switches are used under these conditions for even a short time, they may be adversely affected by improper insulation, a malfunction due to swelling of the potting resin, or hardening of the lead wires.
- Do not use in an environment with temperature cycles.**
Consult with SMC if switches are to be used where there are temperature cycles other than normal temperature changes, as they may be adversely affected internally.
- Do not use in an environment where there is excessive impact shock.**
<Reed switches>
When excessive impact (300 m/s² or more) is applied to a reed switch during operation, the contact point may malfunction and generate or cut off a signal momentarily (1 ms or less). Consult with SMC regarding the need to use a solid state switch depending on the environment.
- Do not use in an area where surges are generated.**
<Solid state switches>
When there are units (solenoid type lifters, high frequency induction furnaces, motors, etc.) which generate a large amount of surge in the area around cylinders with solid state auto switches, this may cause deterioration or damage to the switches. Avoid sources of surge generation and crossed lines.
- Avoid accumulation of iron debris or close contact with magnetic substances.**
When a large amount of ferrous debris such as machining chips or spatter is accumulated, or a magnetic substance (something attracted by a magnet) is brought into close proximity with an auto switch cylinder, it may cause the auto switches to malfunction due to a loss of the magnetic force inside the cylinder.

Maintenance

⚠ Warning

- Perform the following maintenance periodically in order to prevent possible danger due to unexpected auto switch malfunction.**
 - Securely tighten switch mounting screws.
If screws become loose or the mounting position is dislocated, retighten them after readjusting the mounting position.
 - Confirm that there is no damage to lead wires.
To prevent faulty insulation, replace switches or repair lead wires if damage is discovered.
 - Confirm that the green light on the 2-colour indicator type switch lights up.
Confirm that the Green LED is ON when stopped at the set position. If the Red LED is ON when stopped at the set position, the mounting position is not appropriate. Readjust the mounting position until the Green LED lights up.

Other

⚠ Warning

- Consult SMC concerning water resistance, elasticity of lead wires, and use at welding sites.**

Standard type
CA2

Standard type
CA2W

Standard/Non-rotating rod
CA2K

Standard/Non-rotating rod
CA2KW

Low friction
CA2□Q

End lock
CBA2

Air-hydro
CA2□H

Air-hydro
CA2W□H

Auto switch

Made to order

Precautions



Series CA2 Specific Product Precautions

Be sure to read before handling.
Refer to page 72 for safety instructions.

Operation

⚠ Caution

1. Do not open the cushion valve beyond the stopper.

A snap ring is installed as a cushion valve retention mechanism. Do not open the cushion valve beyond it.

If not operated in accordance with the above precautions, the cushion valve may be ejected from the cover when air pressure is supplied.

Bore size (mm)	Cushion valve	Width across flats	Hexagon wrench
40, 50	MB-32-10-C1247	2.5	JIS 4648 Hexagon wrench key 2.5
63, 80, 100	MB-63-10-C1250	4	JIS 4648 Hexagon wrench key 4

2. Use the air cushion at the end of cylinder stroke.

If the cushion valve is used fully open, a type without cushion must be selected. Otherwise, the tie-rod or piston rod assembly will be damaged.

⚠ Caution

1. Do not use a pneumatic type as an air-hydro cylinder. It can cause oil leakage.
2. Mount the rod boot so that it will not be twisted.

The boot rod may be damaged if twisted on installation.

Disassembly/Replacement

⚠ Caution

1. Use a socket wrench when the bracket is replaced.

If other tools are used, the nut or other parts may be deformed or the work efficiency may decrease.

For applicable sockets, please refer to the table below.

Bore size (mm)	Nut	Width across flats	Socket
40, 50	JIS B1181 Class 3 Intermediate M8 x 1.25	13	JIS B4636 + Two-angle socket 13
63	JIS B1181 Class 3 Intermediate M10 x 1.25	17	JIS B4636 + Two-angle socket 17
80, 100	JIS B1181 Class 3 Intermediate M12 x 1.75	19	JIS B4636 + Two-angle socket 19

2. Do not replace the bushing.

Since the bushing is press fitted, the entire cover assembly instead of a single part needs to be replaced.

3. When a seal is replaced, apply grease to the new seal before it is assembled.

Operation of the cylinder without greasing will result in extreme abrasion of the seal, causing premature air leakage.

4. The trunnion type cylinder requires mounting accuracy.

The trunnion type cylinder may lose dimensional accuracy and malfunction when it is disassembled and reassembled because the axial centre of the trunnion and that of the cylinder will not be aligned easily.

Water Resistant Air Cylinders

Series CA2 air cylinders with improved water tight are also available. Because they provide better coolant resistance than the standard cylinders, they are ideal for use in a machine tool environment exposed to coolant. They are also well suited for use in areas in which water splashes, such as food processing equipment or car washers. Please contact SMC for more information.

Auto Switch Mounting Band Selection

1. Series CDA2 cylinders vary in their bore sizes because of difference in the thickness of their tube walls among different models.

The part number of the auto switch mounting band thus varies depending on the cylinder type.

When an auto switch mounting band is ordered alone, please confirm the cylinder type and refer to the table below.

<Cylinder model>

Standard: CDA2/CDA2W

Non-rotating rod: CDA2K/CDA2KW

End lock: CDBA2

Auto switch model (Band mounting type)	Band part No.				
	Cylinder bore size (mm)				
	40	50	63	80	100
D-A3□/A44 D-G39/K39	BDS-04M	BDS-05M	BMB1-063	BMB1-080	BMB1-100
D-B5□/B64 D-B59W D-G5□/K59 D-G5□W/K59W D-G59F D-G5NLT	BH2-040	BA5-050	BAF-06	BAF-08	BAF-10

<Cylinder model>

Low friction: CDA2□Q

Air-hydro: CDA2□H / CDA2W□H

Auto switch model (Band mounting type)	Band part No.				
	Cylinder bore size (mm)				
	40	50	63	80	100
D-A3□/A44 D-G39/K39	BD1-04M	BD1-05M	BD1-06M	BD1-08M	BD1-10M
D-B5□/B64 D-B59W D-G5□/K59 D-G5□W/K59W D-G59F D-G5NLT	BA-04	BA-05	BA-06	BA-08	BA-10

2. Interchangeability of band with Series CDA1 (conventional model)

Take precautions since some cylinder models lack interchangeability of auto switch mounting band because they have thinner cylinder tube walls than the conventional Series CAD1.

Cylinder model	Interchangeability of auto switch mounting band
Standard: CDA2/CDA2W Non-rotating rod end type: CDA2K/CDA2KW End lock: CDBA2	Without
Low friction: CDA2□Q Air-hydro: CDA2□H/CDA2W□H	Interchangeable (Same part number as that of CDA1)